



PALLET LIVE STORAGE SYSTEM USER MANUAL

#03/2026/ ART.-NR.: 56156



Legal details

BITO-Lagertechnik Bittmann GmbH
Obertor 29
55590 Meisenheim
Germany
Telefon: 0 67 53 122-0
Fax: 0 67 53 122-399
E-Mail: info@bito.com
Managing Directors:
Winfried Schmuck
Uwe Sponheimer
Dominik Freyland-Mahling
Commercial register: Amtsgericht Bad Kreuznach, HRB 2704
VAT registration number: DE 811202181
Obertor 29
55590 Meisenheim

Copyright

This user manual is the property of BITO-Lagertechnik Bittmann GmbH.
Contents may not be copied, distributed or published in whole or in part without the written permission of BITO-Lagertechnik Bittmann GmbH.

Language policy

Our equipment is successfully operated by female and male operators.
We kindly ask for your understanding that we only use the male form in the text for reasons of readability. In all cases, we address female as well as male readers and operators.

	Page
1 Foreword	4
1.1 Safety instructions and exclusion of liability	4
1.2 Applicability of the user manual	4
1.3 Safety instructions	4
1.4 Hazard communication	5
1.5 Know your hazard symbols	5
2 General safety instructions	6
2.1 Symbols and signs	6
2.2 Hazard prevention	7
3 Intended use	8
3.1 Non-intended use	8
3.2 OPERATOR'S DUTY OF CARE	9
3.3 Qualified operators	9
4 Technical specifications	10
4.1 Technical data	10
4.2 Operating conditions	10
4.3 First-in, first-out inventory management	11
4.4 Last-in, First-out inventory management (push-back racking)	11
5 BITO Pallet live storage system	12
5.1 Components	12
5.2 Safety components	13
5.3 Components	14
6 Shipping and storage	16
6.1 Delivery	16
6.2 In-house transport	16
6.3 Storage	17
7 Assembly	18
7.1 Instructions of assembly and use	18
8 Operation	19
8.1 Service vehicle	19
8.2 Load carriers	19
8.3 Loads	19
8.4 Operational safety	20
8.5 Pallet loading in first-in, first-out order	21
8.6 Pallet retrieval in first-in, first out order	22
8.7 Loading in last-in, first-out order	24
8.8 Retrieval in last-in, first out order	26
9 Cleaning and maintenance	28
9.1 Cleaning	28
9.2 How to hinge up a roller conveyor segment	28
9.3 How to hinge down a roller conveyor segment	29
9.4 Maintenance	30
9.5 Weekly inspection	30
9.6 Service life of brake rollers	31
9.7 Flow test	31
9.8 Annual inspection	31
9.9 Inspection of static components and procedures	32
9.10 Inspection of dynamic components and procedures	35
10 Access Kit applications	37
11 Troubleshooting chart for handling pallets that disrupt the workflow	38
12 Instructions and work equipment	40
12.1 General information	40
12.2 Troubleshooting notes	40
12.3 Cleaning notes	40
12.4 Instructions on maintenance and repair	40
12.5 Instructions on personal protective equipment	41
12.6 BITO FallPROtect joining and lifting equipment	42
12.7 General accessories, work equipment and tools	43
13 Fault correction phases	44
13.1 Phase 1	44
13.2 Phase 2	44
13.3 Phase 3	60
14 Detailed notes on work equipment, tools and protective equipment to prevent accidents	58
14.1 Notes on forklift trucks	58
14.4 Notes on the body harness	58
14.5 Notes on board care and storage	59
14.6 Notes on annual inspection	59
15 BITO-FallPROtect manual and inspection log	60
15.1 Notes for safe usage	60
15.2 Technical safety requirements for fall arrest systems and assembly	61
15.3 Assembly	62
15.4 Storage / care	63
15.5 Testing	63
15.6 Service life	63
15.7 Compatibility	63
15.8 Evidence of periodic testing	64
16 Repair	65
16.1 Qualified staff	65
16.2 Replace in-feed guide	65
16.3 Replace in-feed guide	67
16.4 Replace brake roller	69
16.5 Replace roller conveyor guard	71
16.6 Replace roller conveyor guard	72
16.7 Replace load separator flag	83
17 Spare parts	74
18 Index	77

1 Foreword

This user manual is provide all the information needed to operate the racking system successfully and efficiently.

The manual includes information on safety, intended use, operating modes and system components as well as proper use, maintenance, troubleshooting and repair.

1.1 Safety instructions and exclusion of liability

This user manual must be made available to every user before the racking system is put into operation. If this manual is needed in other languages, please contact BITO-Lagertechnik Bittmann GmbH. In case of any other questions, please do not hesitate to contact our customer service.

All instructions given in this document must be followed at all times.

Please keep a copy of this manual near your racking installation and in a place that is accessible to all operators.

BITO-Lagertechnik Bittmann GmbH shall not be held liable for any damage arising from failure to observe these operating instructions and the maintenance schedule for industrial racking systems or from incorrectly performed repair work. This user manual is included in the scope of delivery and must also be made available to any later operators.

1.2 Applicability of the user manual

These operating instructions are part of the scope of delivery and only of relevance for the system delivered. They become invalid if the system is modified or components are fitted that were not supplied by BITO-Lagertechnik Bittmann GmbH.

Permitted modifications to the equipment or in the operating mode of the racking system are described in the supplements to this user manual. These are an integral part of the user manual.

1.3 Safety instructions

Please observe all safety instructions and precautions in this manual.

General safety instructions can be found in chapter „General safety instructions“ on page 6.

Safety instructions that refer to hazards when carrying out specific tasks are included in the assembly instructions and other user documents.

1.4 Hazard communication



HAZARD SYMBOL!
Type and source of danger
Potential consequences of non-observance
Preventive measures

1.5 Know your hazard symbols



DANGER!
Indicates an immediate hazard which, if not avoided, will result in death or serious injury.

WARNING!
Indicates an immediate hazard which, if not avoided, can result in death or serious injury.

CAUTION!
Indicates an immediate hazard which, if not avoided, can result in minor or slight injury.



NOTE!
Potentially hazardous situation which could cause damage to equipment and surroundings.

Any shelving or racking system may involve hazards even if it has been correctly designed, assembled and put into operation.

Please note that accidents with serious injuries and fatal outcomes are possible if the instructions and safety regulations in this user manual are not observed.

Please note that failure to observe the instructions and safety regulations in this user manual may result in damage to the racking system and other material goods.

BITO storage systems may only be operated by qualified and instructed operators (see chapter 3.3 Operator qualification).

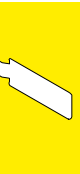

2 General safety instructions

Always observe the following safety instructions when carrying out any activity related to the racking system:



DANGER!
Risk of slipping and falling
Racking levels without railing
Do not climb into racking
Use service vehicles as intended by user manual



DANGER!
Risk of slipping and falling
Rollers are components in motion
Do not walk on rollers



WARNING!
Crush hazard
Moving parts and uncovered loads
Keep hands clear



WARNING!
Crush hazard
Movable components will move when pallets are travelling down the lane or are pushed back
Keep hands clear

2.1 Symbols and signs

	Observe all relevant accident prevention regulations		Wear head protection		Use hand protection
	General warning sign		Foot protection required		Use hearing protection
	Risk of falling		Use eye protection		Pedestrians prohibited
	Risk of hand injury		Wear safety waistcoat		Climbing prohibited
	Warning of obstacles on the ground		General instruction sign		Use safety harness
	Warning of automatic start-up				Unauthorised persons prohibited
	Read and follow the operating and safety instructions before use!		FIFO First-in, first-out inventory management		LIFO Last-in, first-out inventory management

Table 1 : Symbols and signs

2.2 Hazard prevention

The following measures must be observed by operators and users to prevent accidents and damage.

- Only instructed and qualified operators may operate the system.
- Annually refresh health and safety training to increase safety at work.
- The limit values specified in the technical documentation must not be exceeded at any time.
- Assembly and operating instructions must be followed.
- The system must be checked and maintained as specified.
Adequate lighting must be provided.
- Provide separate vehicle trafficways and pedestrian walkways.
- Only use suitable and approved service vehicles and load carriers.
- All relevant legal regulations must be complied with.
- Operators must wear close-fitting work clothing.
- Operators must wear personal protective equipment.
- Operators must not wear jewellery.
- Long hair must be tied up or worn under suitable head covering.

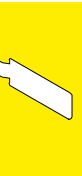

3 Intended use

The BITO pallet live storage system has been designed for storing goods on standard load carriers with a specified load capacity that are appropriate for use on gravity-driven roller conveyors in a suitable environment.

Any other use or any use exceeding that specified is an infringement of use for the intended purpose.

Design, optional equipment, assembly & operating instructions as specified in the order confirmation and in the technical documents must be observed.

Modifications and extensions are not permitted.

Only appropriate service vehicles and load carriers as specified in the order documents may be used.

3.1 Non-intended use

BITO Pallet live storage must not be used for transporting persons or loose goods (goods without the above-mentioned approved load carriers).

For approved and non-approved operating conditions see chapter „4.2 Operating conditions“ on page 10

Prior written consent must be obtained from BITO-Lagertechnik Bittmann GmbH for all cases of use deviating from the intended use.



The specified single and total loads must not be exceeded under any circumstances. Please refer to the racking load sign.

Innovative Storage Solutions **BITO**
WWW.BITO.COM

Bei Veränderungen der Regalkonstruktionen beachten:
 • Einhaltung der Herstellerdaten!
 • Genehmigung des Lieferanten besorgen!

Regale nicht bestiegen!

Schäden am Regal unverzüglich dem Sicherheitsbeauftragten melden!

Regelmäßige Regalprüfung durchführen:
 • auf richtige Anwendung
 • legen die zulässigen Belastungen innerhalb der angegebenen Belastungswerte
 • unbedingte Schäden bzw. Beschädigungen an tragenden Bauteilen umgehend beheben lassen
 • Richten und Leitfaden zum sicheren Umgang mit dem Regal beachten
 • im Zweifelsfall immer den Hersteller einschalten

Paletten-Durchlaufregal-System
 Bauplan: Auftrags-Nr.:

System Rollenbahn

Stützen-Typ:

Feldbreite FB: mm mm mm

Fachabstand FA1 max.: mm

Fachabstand FA2 max.: mm

Rollenteilung: mm

Gebinde-Typ: EURO-Palette

Abmessungen (BxLxH) x x mm
(inklusive Palette)

Einlagerung: längs

Gewicht Palette/Gebinde: min. kg
max. kg

! Alle Werte gelten bei gleichmäßig verteilter Last! Aufbau- und Bedienanleitung beachten!

Regalinspektion
gemäß DGM 138-027 und DIN EN 13823
Hinweis: Die Prüfberichte sind kein Ersatz für eine Probefahrt!
Service: service@bito.com interne Regalinspektion

BITO-Lagertechnik Tel.: 0049 (0)6753 122 0
 Bittmann GmbH Fax: 0049 (0)6753 122 399
 Oberle 29 info@bito.com
 55590 Meisenheim www.bitocom

Figure 1: Example of a racking load sign



All system relevant safety and operating instructions including the racking signs must be kept in legible condition.

3.2 OPERATOR'S DUTY OF CARE

Pallet live racking operators must comply with the legal obligations for occupational safety as well as the relevant safety, accident prevention and environmental protection regulations.

The operator must observe the following points:

1. Know the applicable occupational health and safety regulations and keep informed. In a hazard assessment, additional hazards must be identified that may arise as a result of the special working conditions at the place of use of pallet live storage systems. These must then be implemented with the help of operating instructions for the use of pallet flow racking.
2. The operating instructions must be regularly adapted to reflect the current regulations.
3. A hazard zone around pallet live storage racking must be defined; unauthorised persons must not be allowed to enter this hazard zone.
4. Employees must have read and understood the operating instructions of the pallet live storage racking. Regular training and safety instructions on potential risks must be carried out.
5. Employees must be provided with protective equipment.
6. The operator must make sure that the pallet live storage facility is only used for its intended purpose and that it is maintained in a perfect, functional condition.
7. The pallet live storage installation must be checked and inspected at regular intervals.
8. Inspection and maintenance intervals must be observed.

3.3 Qualified operators

Qualified operators are those persons who can read, understand and follow these operating instructions and the legal regulations.

They are able to operate service vehicles correctly and have the necessary authorisation and qualification. Personal protective clothing is mandatory when working in the racking, see page 41 „Notes on protective clothing“.

The legal regulations on occupational safety and accident prevention, and in particular, DGUV rule 208-061 (German Statutory Accident Insurance Regulations) or the equivalent national regulation must be known and observed.

Qualified operators also require system-specific training.

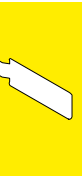

4 Technical specifications

The main features of pallet live storage are:

- goods move gravity-driven
- inclined roller lanes
- suited for pallets or similar load carriers
- compact storage
- channel storage
- load carriers move unassisted from the loading side to the picking side

4.1 Technical data

This table contains default values. The data relevant for your project can be found in your order documents.

Load capacities	
Minimum and maximum load capacities per load carrier	Please refer to order documents
Maximum speed	0.3 m/s
Lane incline	The standard lane incline is 4%, the project specific lane incline can deviate (see order documents).
Load carriers	
Flat wooden pallet sized 800 x 1200 mm as specified in DIN 13698-1 (European pool pallet)	stored short side or long side facing
Flat wooden pallet sized 1000 x 1200 mm as specified in DIN 13698-2 (industry pallet)	stored short side or long side facing
CHEP industry pallet 1000 x 1200 mm as specified in B1210A	stored short side or long side facing
Wire-mesh box pallet as specified in UIC standard 435-3 DIN 15155	stored short side facing
H1 pallet as specified in DIN EN 55423-5/6	stored short side facing
Other load carriers	as specified in order documents

Table 2 : Technical default data

4.2 Operating conditions

BITO Pallet live storage racking can be operated at a constant temperature range of -30°C to +50°C.

Do not operate in locations with

- water condensation
- atmospheric corrosion
- contact with liquids
- abrasive media
- vibrations
- explosions
- radiation
- Do not operate with load carriers and loads that can oxidise, rust or decompose
- can block the function of lane components
- can soil racking components
- impair the functionality of mechanisms

4.3 First-in, first-out inventory management

In FIFO operations (First-in, First-out), pallets are fed into the lanes at the loading side of a racking block and retrieved at the opposite side. Pallet movement to the picking side is aided by lane incline and gravity. As soon as the first pallet at the picking side has been retrieved, the other pallets in the lane move forward by one position without external intervention.

A load separator at the picking side ensures that service vehicles can retrieve the pallet at the front without having to compensate for lane pressure. Products are stored in FIFO order. Please note that not all racking installations have load separators at the picking side.

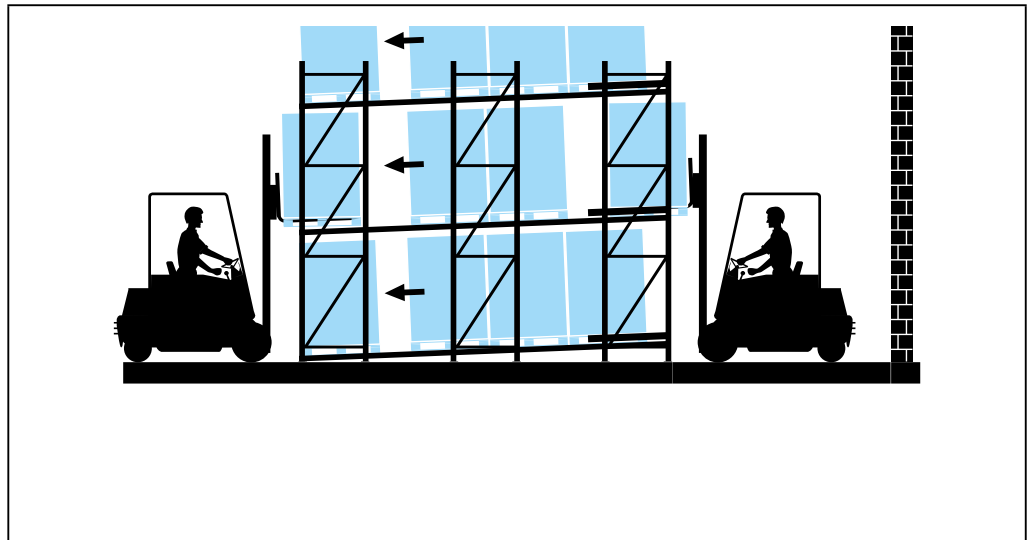

Figure 2: Storage in FIFO order

4.4 Last-in, First-out inventory management (push-back racking)

Push-back pallet racking is loaded by service vehicles pushing pallets into the lane against the incline. By taking out the first pallet, the lift truck driver triggers pallet movement of the remaining pallets in the lane.

BITO push-back racking comes with brake rollers to prevent uncontrolled pallet acceleration and exclude product damage and bodily injury. Push-back racking is accessed from only one side. Products are stored in LIFO order.

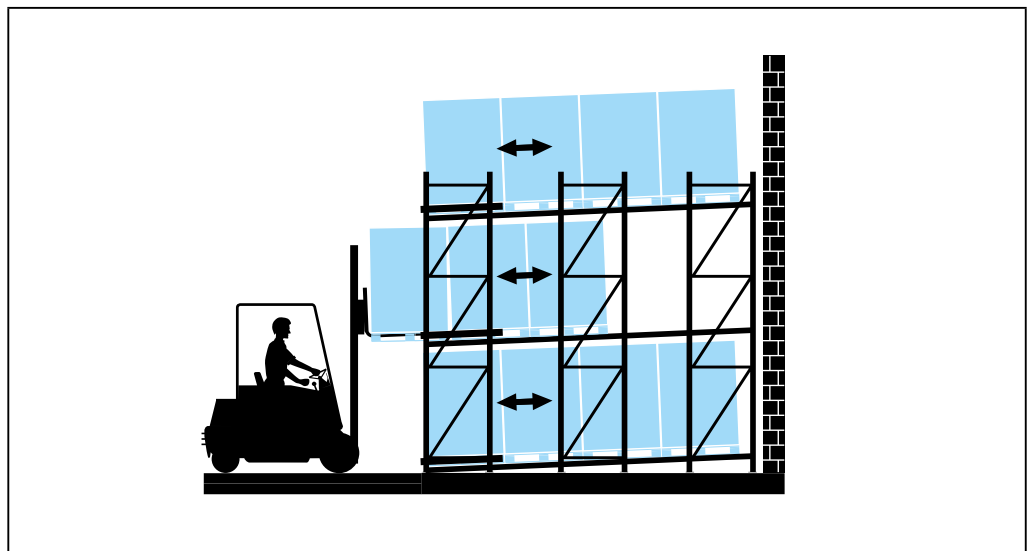

Figure 3: Storage in LIFO order

5 BITO Pallet live storage system

5.1 Components

1. Bolt-on connectors allow continuous height adjustment of lanes
2. Angular beam profiles provide protection for roller lanes and serve as lane end stop for load carriers
3. Conveyor roller
4. Brake rollers ensure an evenly braked pallet throughfeed
5. In-feed guide
6. Front/rear roller lane protector
7. Roller conveyor side guard
8. Floor beam
9. FlowStop Load separator
10. Mid-lane separator: used in long lanes to absorb lane pressure by keeping other pallets in the lane from moving forwards
11. Speed-reducing slope on hand pallet truck retrieval unit
12. Hand pallet truck retrieval unit
13. Triple track unit on the picking side
14. Triple track unit on the loading side
15. Tiltable roller lane segment
16. Pallet handled long side facing
17. Pallet handled short side facing
18. Column guard for corner uprights
19. Upright protector
20. Wire-mesh side cladding
21. Truck wheel stopper

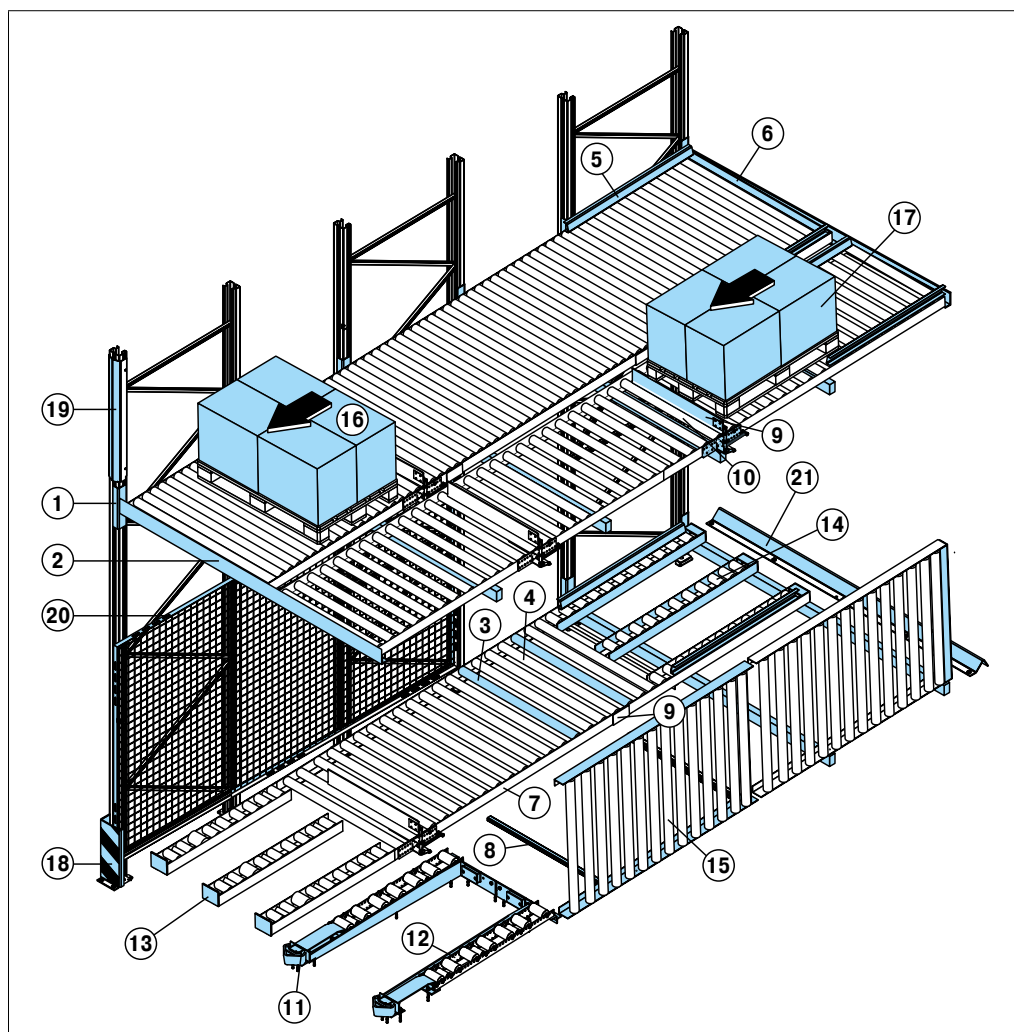
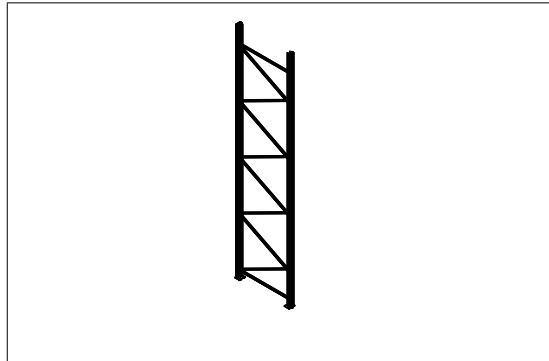
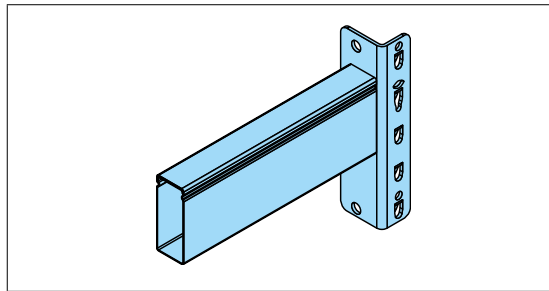

Figure 4: Pallet live storage system with main components

5.2 Safety components



PRO Pallet racking frame



BITO TwinTop® beams

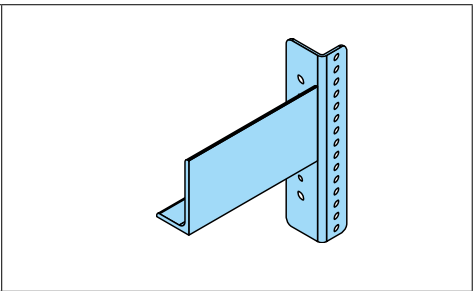

Angled beam profile

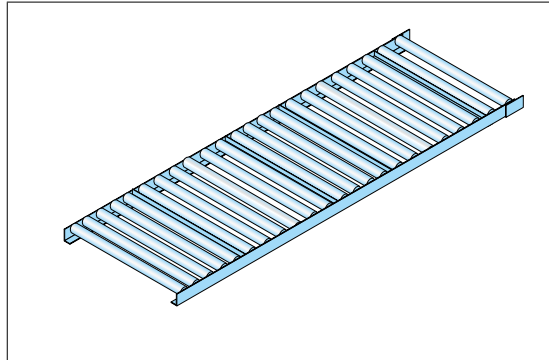

Lane segment with full-width rollers

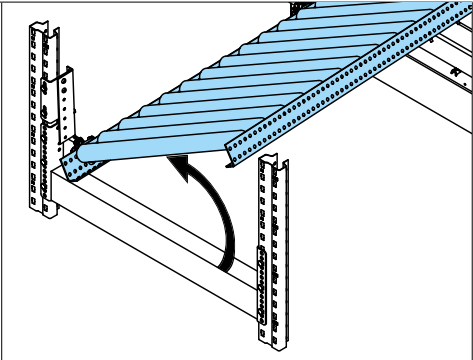

Tilttable roller conveyor segment

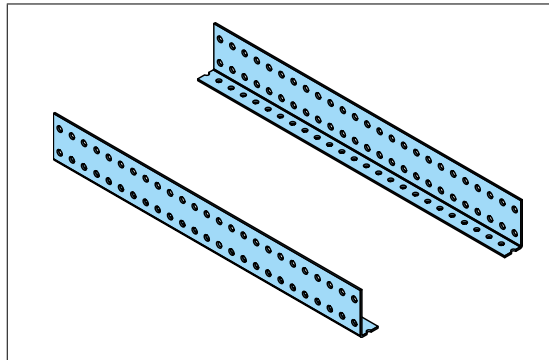

Roller lane side guards

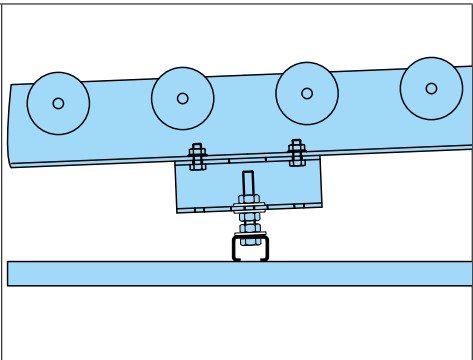

Height adjustable floor beam

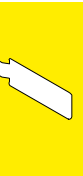

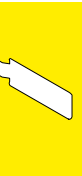

5.3 Components

<p>Full-width brake roller</p>	<p>Conveyor roller</p>
<p>Retrieval unit, standard version</p>	<p>Retrieval unit, heavy-duty version</p>
<p>Loading unit with full width rollers</p>	<p>Triple track loading unit</p>
<p>Retrieval unit with full width rollers</p>	<p>Triple track retrieval unit</p>

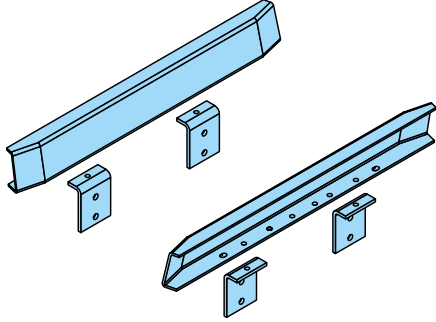
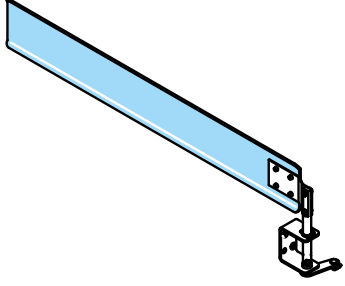
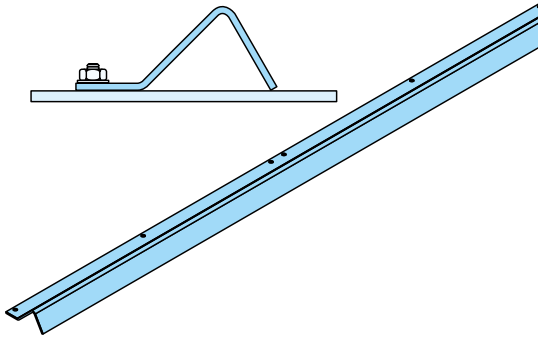
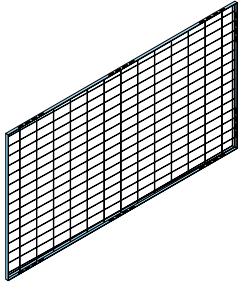
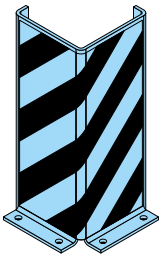
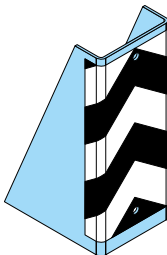
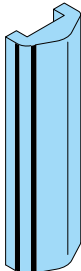
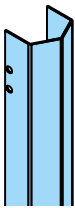
		
<p>In-feed guide</p>	<p>FlowStop Load separator</p>	
		
<p>Full-width truck wheel stopper</p>	<p>Wire-mesh side cladding</p>	
		
<p>L-shaped column guard</p>	<p>U-shaped column guard</p>	<p>Flexible upright protector</p>
		
<p>Upright protector</p>		

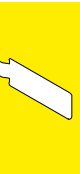

6 Shipping and storage

6.1 Delivery

To ensure that pallet live storage racking reaches its place of use without damage, care is taken with packaging.

- Document any damage detected upon delivery and check whether the delivery is complete.
- Look out for loose components.
- Notify the manufacturer and the freight forwarder in writing in the event of transport damage.

6.2 In-house transport



WARNING!

Beware of suspended loads and falling materials!

- Lifting equipment and crane systems must be suitable for lifting the load in question and must be approved for the purpose.
- Only use specified load lifting equipment.
- Use corner and edge protectors to prevent ropes and chains from ripping.
- Secure loads against sliding during transport.
- Note that the centre of gravity can shift during transport.
- Never stand under a suspended load.



WARNING!

Beware of tipping loads or falling materials!

- Never stand immediately next to or underneath a load that is being lifted.
- Please note: Transport equipment used must be designed for holding the load weight.
- Determine the centre of gravity of the materials to be transported.
- Secure loads against sliding.

The packed goods may be transported to the assembly site with forklift trucks or hand pallet trucks.

Check the weight of each package before handling it with a service vehicle. Do not exceed the maximum load capacity of transport and lifting equipment.

6.3 Storage

Components must be stored in a dry place which is protected against dust, dirt and vibration.

- The packed goods are not suitable for outdoor storage. If they are nevertheless stored outdoors, they must be protected from adverse weather conditions.

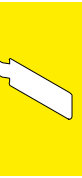

7 Assembly

7.1 Instructions of assembly and use

Assembly and set-up of BITO pallet live storage racking is explained in the following instruction brochures:

	Title	Item no.
1	PROflow Pallet live storage and push-back system	39035
2	PROflow racking with/without FlowStop load separator [T168] FlowStop module with brake roller for pallets handled short side facing	54881
3	PROflow racking with/without FlowStop load separator [T168] FlowStop module with conveyor roller for pallets handled short side facing	54880
4	PROflow racking with/without FlowStop load separator [T144] FlowStop module with brake roller for pallets handled short side facing	42613
5	PROflow racking with/without FlowStop load separator [T144] FlowStop module with conveyor roller for pallets handled short side facing	42612
6	PROflow racking with/without FlowStop load separator [T96] FlowStop module with brake roller	42614
7	PROflow racking with/without FlowStop load separator [T96] Chep pallets, FlowStop module with brake roller	42616
8	PROflow racking with/without FlowStop load separator [T72] FlowStop module with brake roller for pallets handled long side facing	42615
9	Tiltable roller conveyor segment	40062
10	Double-deep pallet live storage racking	55385
11	Control card and instructions of use for carabiners	53572
12	Inspection book and instructions of use for fall arresters HWB 2 + HWB 2 DW	06022018

Table 3 : Overview on instruction booklets with item no.



Figure 5: Sample of BITO instructions of assembly and use

8 Operation

Always observe all operating and safety instructions.



NOTE!
The provisions of DGUV (German Statutory Accident Insurance), rule 208-061, also apply.

8.1 Service vehicle

Truck forks must not stick out at the rear of the load carrier, i.e. they must not be longer than the pallet or the load.

If pallets are handled long side facing, make sure that the forks do not stick out at the pallet rear side.

Make sure that the maximum fork lifting height is sufficient to safely operate all racking levels.

The industrial truck must have the required load capacity for the relevant loads.

8.2 Load carriers

Only use approved, unbroken, dry and clean load carriers.

NOTE!
Damaged, damp or unsuitable pallets must not be loaded into the racking as they may get stuck in the lane.

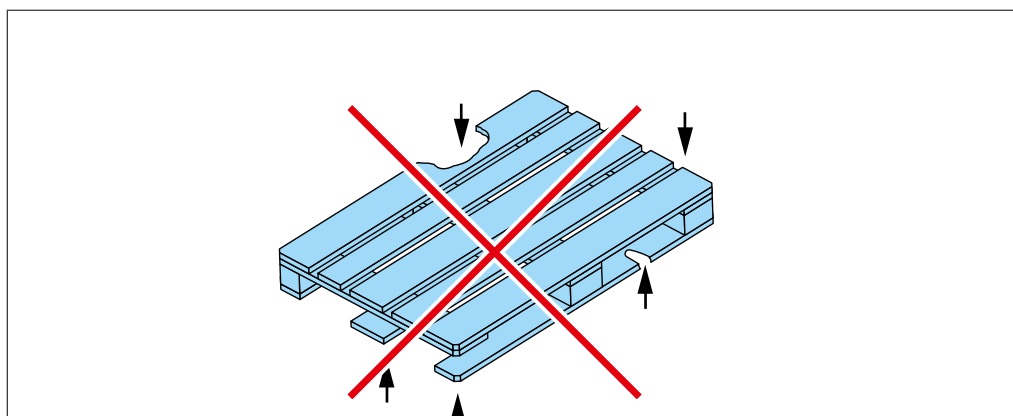

Figure 6: Illustration of a defective load carrier (pallet)

Always observe the minimum and maximum loading weight of a pallet

8.3 Loads

Only feed in pallets that are not overloaded. Also make sure that the load is secured against slipping.

NOTE!
Always secure loads! Do not feed pallets with unstable loads into the racking as they may get stuck in the lane.





8.4 Operational safety

WARNING!

Falling loads can cause injuries and/or fatalities.
Damaged components can lose their load-bearing capacity.
In case of visible damage, immediately stop operation in the affected area.

STOP OPERATION in case of

- Visible damage
- Missing fastenings
- Load carriers not moving on
- Malfunctions
- Unusual noises
- Bolts or other parts and components on the floor

Always keep your racking in safe working order. Block off lanes immediately from further use if you observe the following:

NOTE!

- Visible damage
- Missing fastenings
- Load carriers not moving on
- Malfunctions
- Unusual noises
- Bolts or other parts and components on the floor

CAUTION!

Do not damage the load separator.
Never push pallets back into the rack from the picking side in FIFO operations.

Only store load carriers into racking if these can be fully placed on the roller conveyor lane.

Do not move load carriers back into the racking against the lane pressure from pallets already in that lane (LIFO operation only).

Avoid hitting racking components with lift truck forks.

Immediately close blocked lanes and correct the malfunction.

FIFO

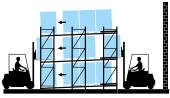

8.5 Pallet loading in first-in, first-out order

1. Check pallets for damage and incorrect load positioning.
2. Make sure that your truck forks do not project beyond the pallet during pallet handling.
3. Position your lift truck straight and centre it in front of the lane that is to be loaded.

Note!

Feed in pallets at the loading side only.

4. Tilt the forks/the mast towards the truck.
5. Lift the pallet to the correct height.
6. Move the truck forward until the pallet is positioned completely above the roller lane and behind the roller lane protector.

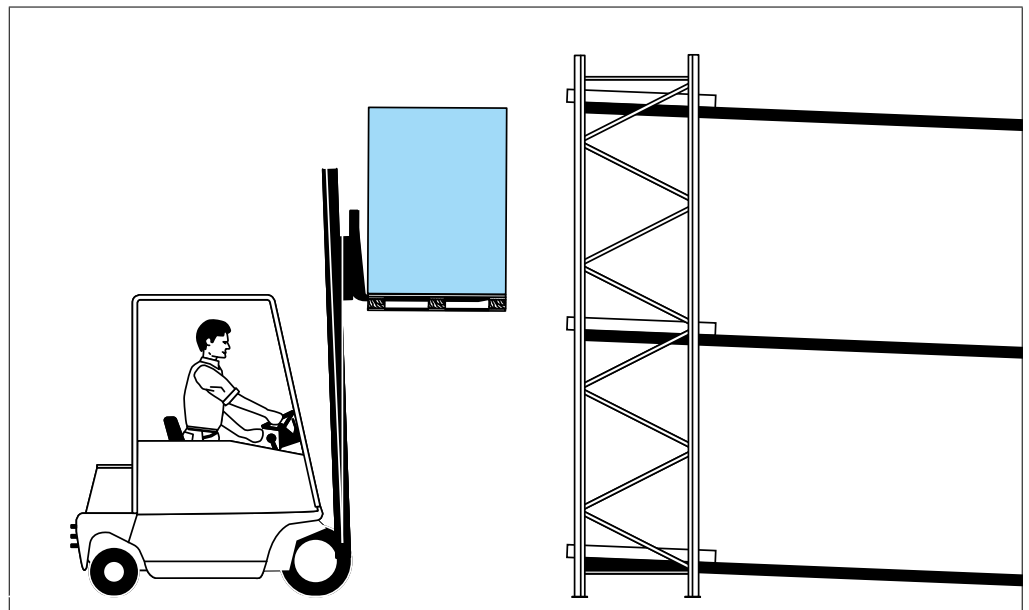

7. Tilt the forks/the mast until the pallet and the roller lane are parallel .
8. Make sure that the pallet sits centred along an imaginary straight line on the roller lane; if necessary, correct the pallet position between the in-feed guides.
9. Avoid shocks and jerks when placing pallets onto the roller lane.
10. Bring the truck forks into a horizontal position as soon as the pallet has moved into the lane and the forks are unloaded.

NOTE!

Pallets placed at an angle can cause jams and block the lane.

11. Drive straight backwards until the fork is out of the racking.
12. Lower the forks into the driving position.



FIFO

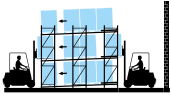

8.6 Pallet retrieval in first-in, first out order

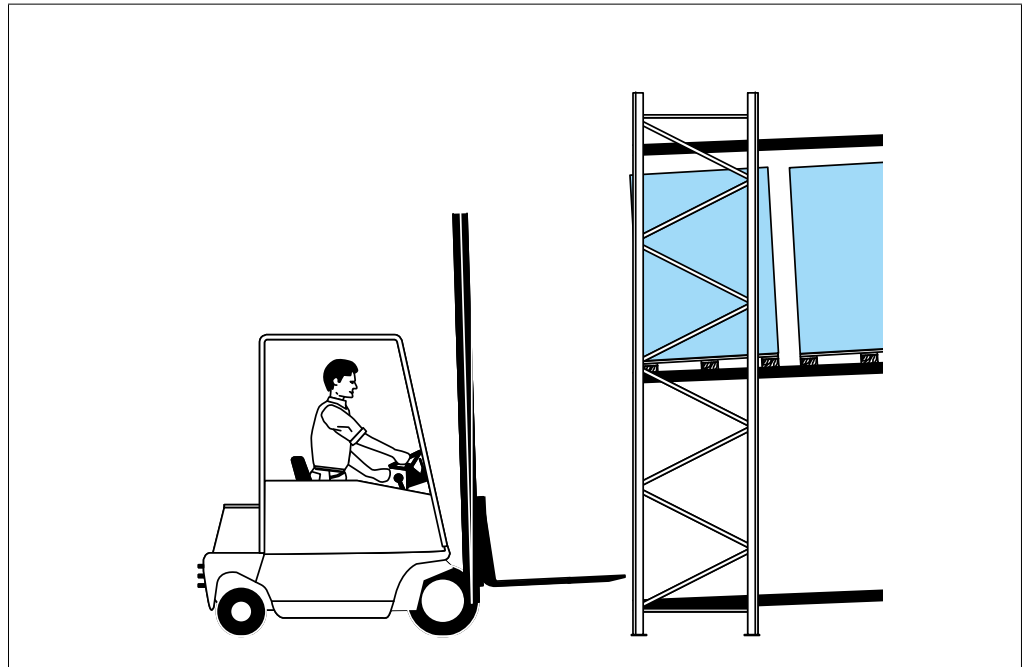

1. Drive towards the pallet position along a straight and centred line.

CAUTION!

Do not damage the load separator.
Never push pallets into the rack from the picking side.

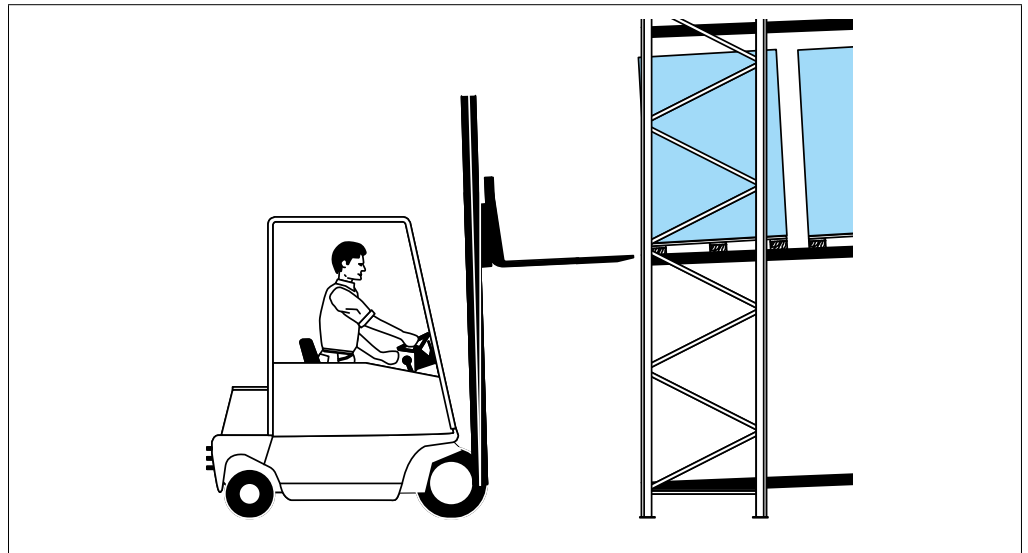

2. Lift the truck forks to the pallet.
3. Tilt the forks/the mast in an angle that corresponds to the lane incline.
4. Only move the forks that far under the pallet that they do not project beyond the pallet.
5. Lift the pallet until there is no more contact to the roller conveyor lane, but not higher than 10 cm in order to avoid hitting the level on top and deactivating the load separator.

**NOTE!**

Do not lift the pallet more than 10 cm in order to avoid hitting the level on top and deactivating the load separator. Pallets that move forward too early will disturb the retrieval process.

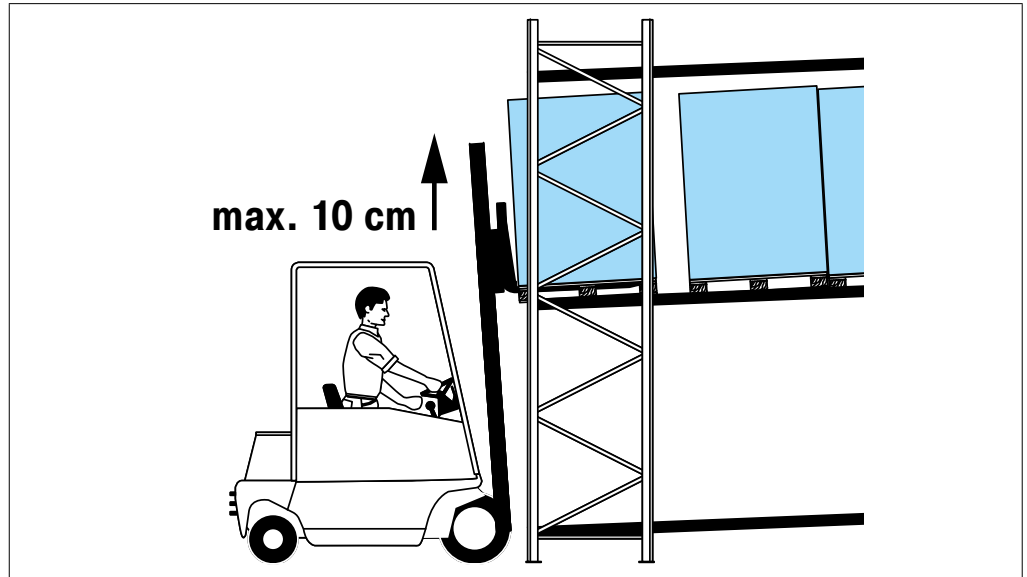

6. Make sure that the pallet will not touch the rack during the picking process.
7. Drive straight backwards until the fork is out of the racking.
8. Lower the pallet.

LIFO



8.7 Loading in last-in, first-out order

1. Check pallets for damage and incorrect load positioning.
2. Make sure that your truck forks do not project beyond the pallet during pallet handling.
3. Tilt the forks/the mast towards the truck.
4. Lift the pallet to the correct height.
5. Tilt the forks/the mast in an angle that corresponds to the lane incline.

NOTE!

Push pallets into a lane only if there is direct pallet-to-pallet contact. Overhanging loads can be damaged.

NOTE!

Slowly push back the pallet against the other pallets that are already in the lane, then let all pallets in that lane move forwards.

6. Upon feeding a pallet into a lane, check whether it will only touch the pallet already in the lane and not the load.
7. Move the truck forward until the pallet is positioned completely above the roller lane and behind the roller lane protector.
8. Tilt the forks/the mast until the pallet and the roller lane are parallel .

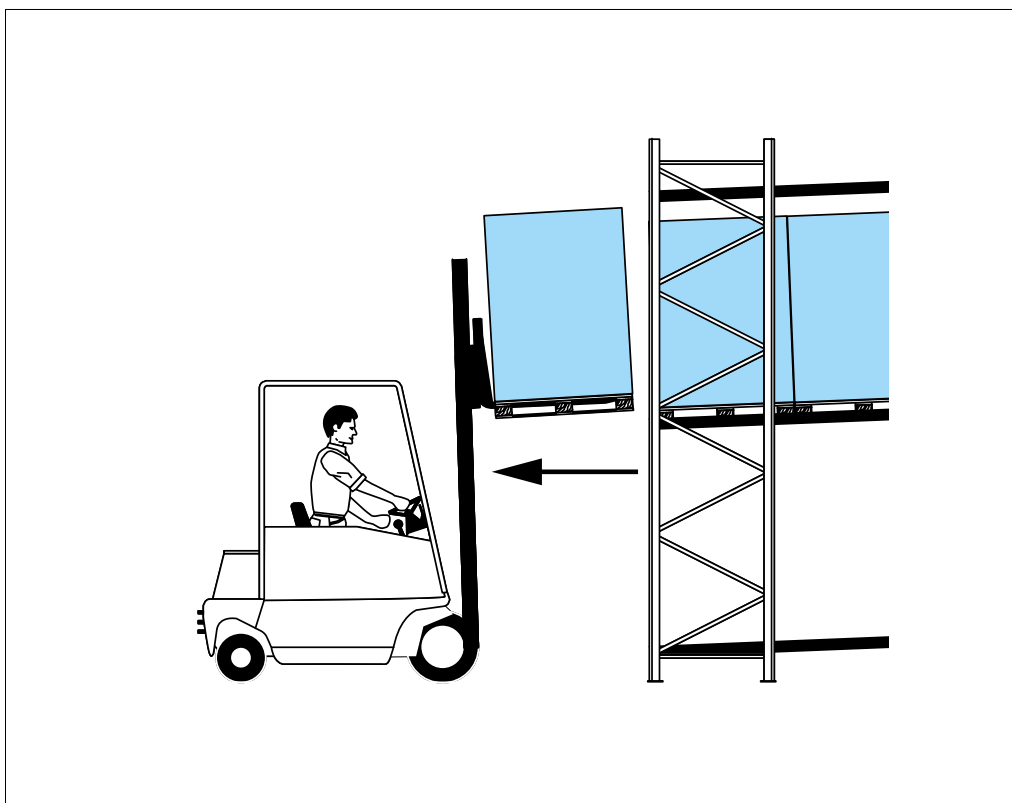

9. Move the truck forwards carefully and slowly, pushing back the pallets already in the lane until the new pallet is positioned completely above the roller conveyor lane, then place it on the rollers.
10. Make sure that the pallet sits centred along a straight imaginary line on the roller lane.



11. Drive straight backwards until the fork is out of the racking.
12. Lower the forks into the driving position.

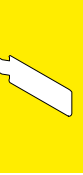

LIFO



8.8 Retrieval in last-in, first out order

1. Drive towards the pallet position along a straight and centred line.
2. Lift the truck forks/the mast to the correct height.
3. Tilt the forks/the mast in an angle that corresponds to the lane incline.

NOTE!

Slowly push back the pallet against the other pallets that are already in the lane, then let all pallets in that lane move forward.

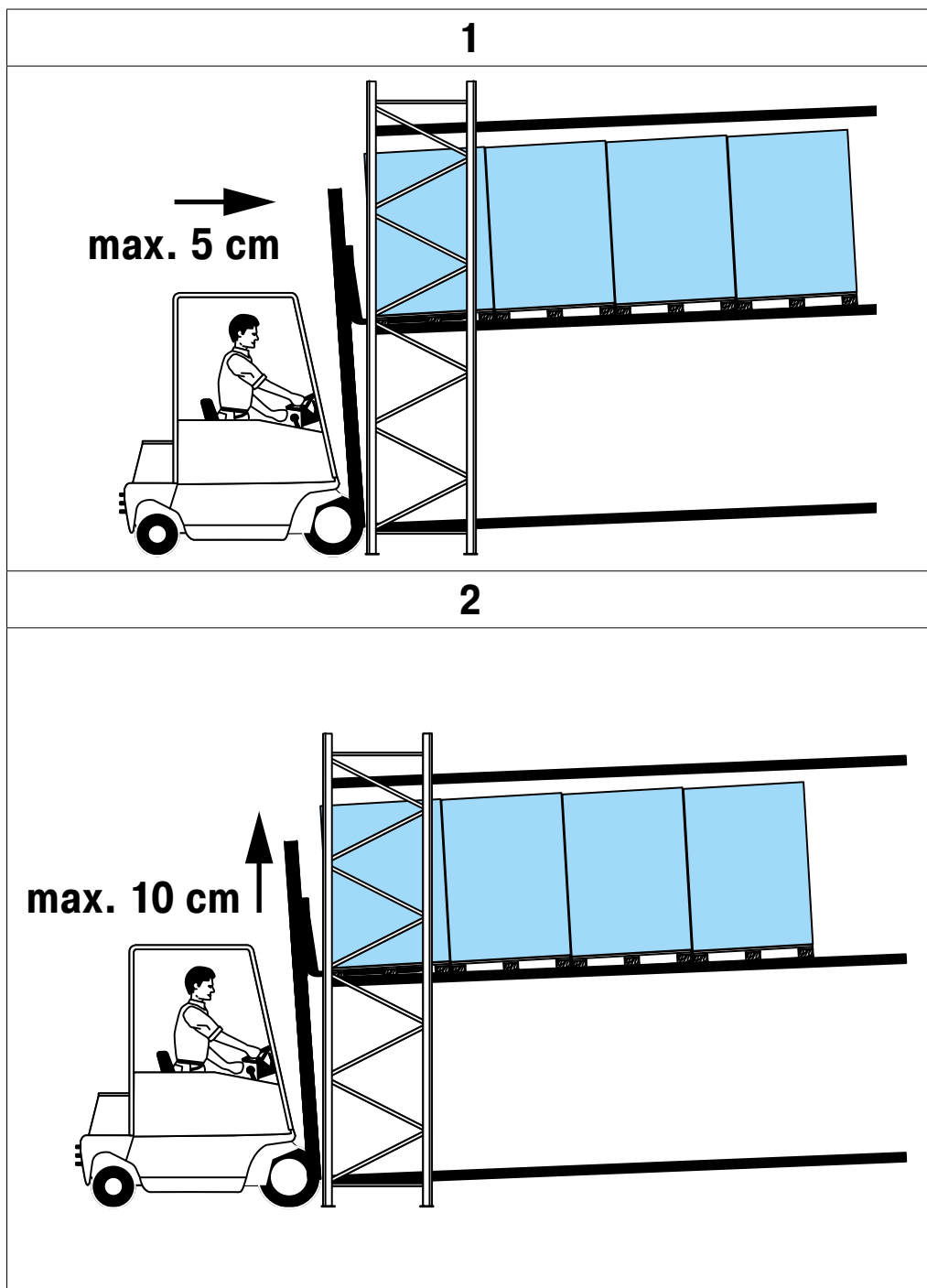

4. Move the lift truck forwards by 5 cm, thereby pushing backwards all pallets in that lane away from the front stop. The first pallet can then be lifted without damaging the front stop.
5. Lift the pallet until there is no more contact to the roller conveyor lane (10 cm max.).



6. Push the pallets in that lane backwards by 5 cm and lift the pallet to be retrieved by 10 cm. Drive straight backwards until the fork is out of the racking.

NOTE!

Check that the remaining pallets in that lane move forward again. Drive slowly enough so as not to interrupt the contact between the pallets.

7. Lower the pallet.
8. Check whether the remaining pallets in the lane have moved to the front stop in a straight line.

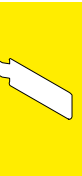

9 Cleaning and maintenance

9.1 Cleaning

Clean the rack without using water or other liquids. We recommend sweeping, brushing, cleaning with a cloth or vacuum-cleaning. Most important is the removal of foreign objects.

CAUTION!
 Corrosion damage
 Do not use water
 Do not use cleaning substances
 Do not use pressure washers

9.2 How to hinge up a roller conveyor segment

Roller conveyor segments at floor level height can be hinged up to clean the floor below (Note: applies only to the hinge-up variant).

NOTE!
 Two operators are required to hinge up or down roller conveyor segments.

NOTE!
 Always wear protective clothing when working with the rack.

1. Take the roller conveyor segment by the handles on the side guard (1) with two persons.
2. Tilt up the roller conveyor segment - the opposite roller conveyor side is the axis of rotation.

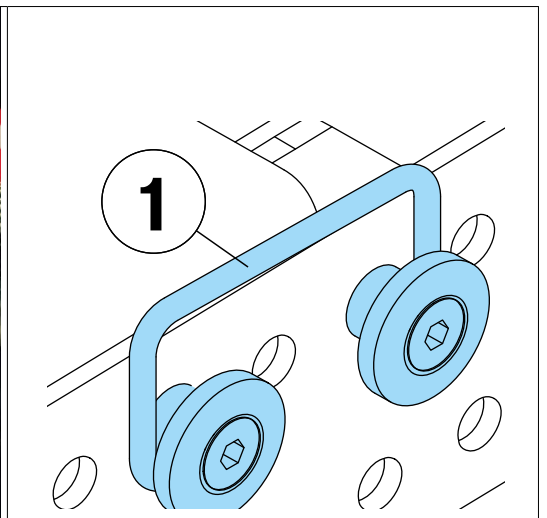
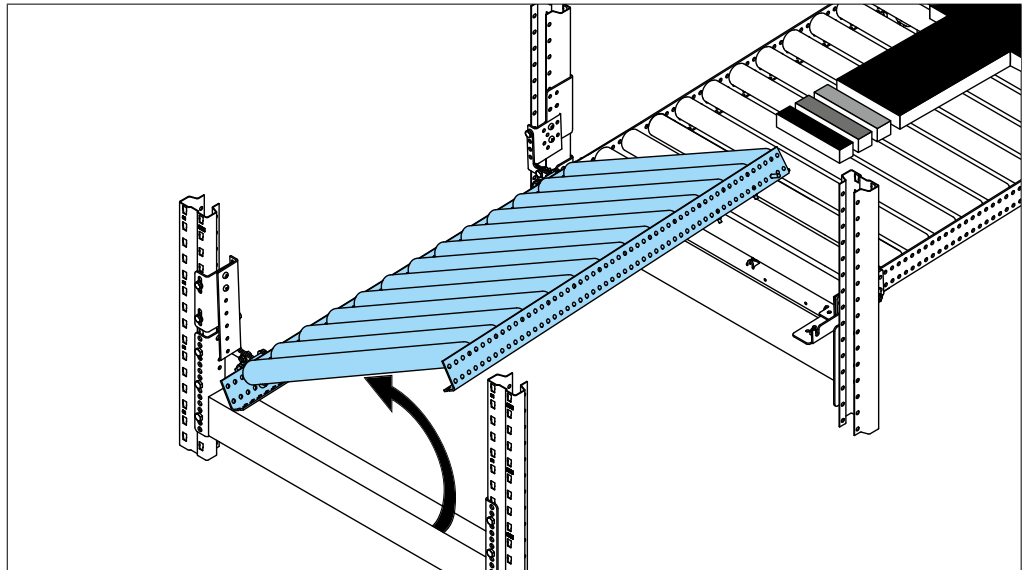
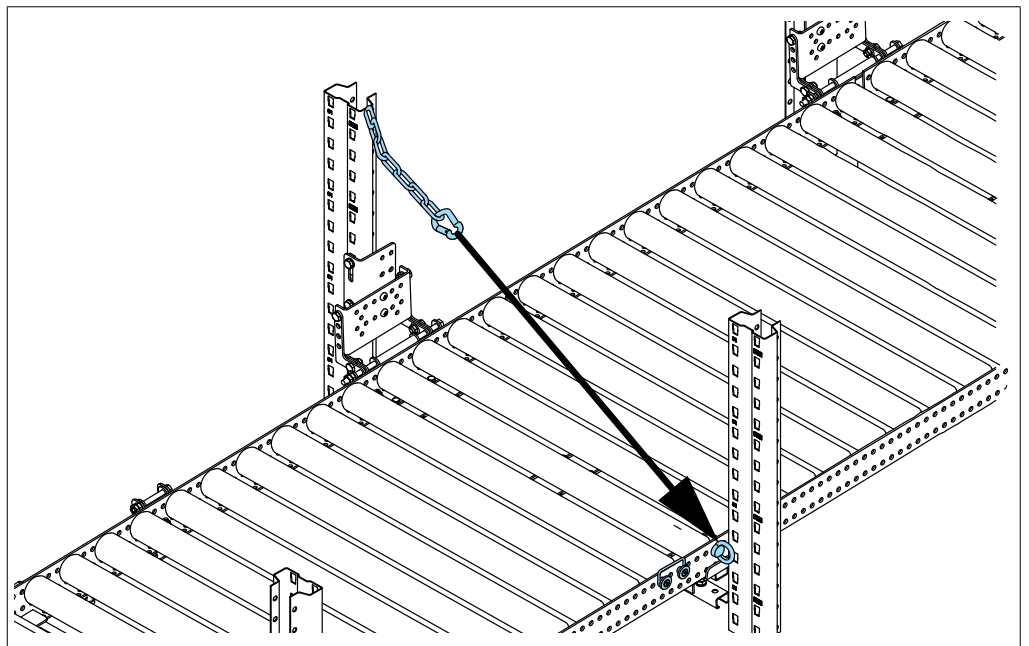

Table 4 Photo: Roller conveyor segment with handle

- Lift the roller conveyor segment into the vertical position.



- Secure the roller conveyor segment by clipping the carabiner into the safety eyelet on the roller conveyor side profile.



9.3 How to hinge down a roller conveyor segment

- Take the roller conveyor segment by the handles on the side section with two persons.
- Unclip the carabiner from the safety eyelet.
- Lower the roller conveyor segment into the horizontal position.



WARNING!

Danger of crushing
Closing gap
Keep hands on the handles

9.4 Maintenance

BITO Pallet live storage is maintenance-free.

9.5 Weekly inspection

All parts of the installation must be visually checked on a weekly basis. This applies especially to load-bearing components.

Look out for the following details:

- Damage caused by vehicles
- Screws, nuts or components on the floor
- Loose loads on pallets or in the racking
- Loose packaging materials (wood, foil, cardboard,...)
- Damaged or wrong pallets
- Damaged or jammed rollers

9.6 Service life of brake rollers

The brake rollers have a service life of at least 50,000 run-overs.

9.7 Flow test

We recommend to check the pallet travel speed in each lane at least 4 times per year. The pallets should not move forward faster than 0.30 m/s average speed. Pallet travel speed is calculated as follows:

Average speed = (lane length - pallet length) / travel time

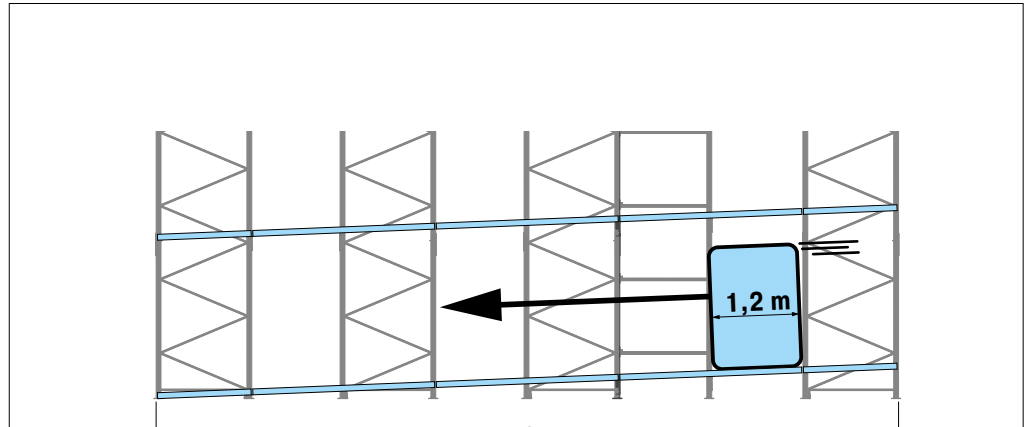

Example:

Lane length = 10 m, travel distance = 10 m - 1 pallet length (f. ex. 1.20 m) = 8.8 m

Measured travel time of a pallet from back to front = 36 seconds
 $8.8 \text{ m} / 36 \text{ s} = 0.24 \text{ m/s}$ = test passed

Measured travel time of a pallet from back to front = 27 seconds
 $8.8 \text{ m} / 27 \text{ s} = 0.33 \text{ m/s}$ = test failed because faster than 0.3 m/s

If the test was not passed, check whether the brake rollers are defective. Replace defective brake rollers (see chapter Repairs, page 69, Replace brake rollers). We strongly recommended to deactivate the lane and have it checked by BITO.

9.8 Annual inspection

In compliance with DIN EN 15635, the racking system must be checked on an annual basis by a BITO racking inspector. The inspection includes visual inspections and pallet test runs to verify that the system performs as intended.

The annual inspection also includes a check on 10% of the lanes for proper lane functioning.

To make an appointment, please contact the BITO After Sales Service:

aftersales@bito.com

Tel. 06753 122 9668
 Fax 06753 122 5665

9.9 Inspection of static components and procedures

In compliance with DIN EN 15635, the following features must be checked once a year by a qualified person and documented in an inspection report.

Components	Activity	Pass criteria
Protection against objects falling within the racking installation	Visual check to determine whether components are in good condition	No deformation or other damage
Protection against objects falling at the racking sides	Visual check to determine whether components are in good condition	No deformation or other damage
Column guards	Visual check to determine whether components are in good condition	No deformation, cracks or other damage, components are firmly fitted
Uprights	Visual check to determine whether components are in good condition	No dents, no cracks or other damage, no loose parts, screws etc.
Strutting	Visual check to determine whether components are in good condition	No dents, no cracks or other damage, no loose parts, screws etc.
Beams	Visual check to determine whether components are in good condition	No dents, no cracks or other damage, no loose parts, screws etc.
Other components	Visual check to determine whether components are in good condition	
Damage due to drilling, welding or adding components	Visual check to determine whether components are in good condition	
Load capacity signs	Check compliance with the specifications	Compare load carrier characteristics with the data on the load capacity sign
Admissible load carriers	Check compliance with the specifications	Compare load carrier characteristics with the data on the load capacity sign
Correct in-feeding of loads	Visual check whether load carriers are in good condition	No defective or damaged load carriers Operation of the system in accordance with the assembly/operating instructions
Safety pins/bolt connections	Visual inspection	Components are correctly and firmly fitted
Racking verticality	Visual inspection for misalignment	Frames are mounted in a vertical position
Bracing	Visual inspection	Components are correctly and firmly fitted
Floor anchoring, shimming of uprights	Visual inspection	Components are correctly and firmly fitted
Spacing of racking levels	Check compliance with specifications	Check compliance with the data on the load capacity sign
Operating instructions or manual	Check availability	Documentation is available
Inspection logs on periodic visual inspections	Check availability	Documentation is available

Signature / Date

Table 5 :Inspection of static components and procedures

All deviations must be rectified immediately as they can cause malfunctions and accidents.



NOTE!

Immediately eliminate possible causes of malfunction. If necessary, have the problem checked by BITO.

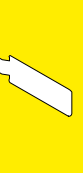

	Inspection interval				Test passed yes / no
	Every day	Every week	Every month	Every year	
		X			
		X			
		X			
		X			
		X			
			X		
			X		
	X				
	X				
	X				
			X		
			X		
		X			
		X			
		X			
				X	
				X	



9.10 Inspection of dynamic components and procedures

In compliance with DIN EN 15635, the following features must be checked once a year by a qualified person and documented in an inspection report.

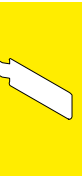

Components	Activity	Pass criteria
System operation	Measure deviation from centre line Centre a pallet in the lane and let it travel down to the picking side. Measure the deviation from the straight travel line.	Deviation < 25mm
Separator	Visual check for proper functioning: Remove all pallets from a lane and verify whether the load separator is working correctly.	System performs as intended. Uniform motion. No excessive noise development.
In-feed guide	Visual check to determine whether components are in good condition	No dents, no cracks or other damage, no loose parts, bolts etc.
Roller conveyor lanes	Visual check to determine whether components are in good condition	No dents, no cracks or other damage, no loose parts, bolts etc.
Conveyor rollers	Visual check to determine whether components are in good condition Measure wear and tear	No dents, no cracks or other damage, no loose parts, bolts etc. Rollers move smoothly without excessive noise development
End stop plates	Visual check to determine whether components are in good condition	No dents, no cracks or other damage, no loose parts, bolts etc. Components are firmly fitted.
Brake rollers	Visual check to determine whether components are in good condition Measure wear and tear	No dents, no cracks or other damage, no loose parts, bolts etc. Rollers turn with a slight resistance, but must not jam; compare with other brake rollers if necessary. Note! Carry out a flow test!
Signature / date		

Table 6 :Guideline for pallet live racking inspection

Replace damaged components or components with limited function!
Refix loose components.

Explanations:

- Measure deviation from centre line: Centre a pallet in the lane and let it travel down to the picking side. Measure the deviation from the straight travel line. Deviation must not exceed < 25mm.
- Check separators: Remove all pallets from a lane and watch whether the separator works as intended upon retrieving a pallet.

All deviations must be rectified immediately as they can cause malfunctions and accidents.



NOTE!
Immediately eliminate possible causes of malfunction. If necessary, have the problem checked by BITO.

	Inspection interval				Test passed yes / no
	Every day	Every week	Every month	Every year	
			X		
	X				
			X		
			X		
			X		
			X		
			X		

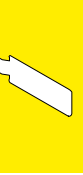

10 Access Kit applications

The BITO Access Kit provides easy and safe access to a trouble spot in pallet live storage racking. In the following, some application examples are presented. The illustrations show the problem on the left and the solution on the right side.

Troubleshooting



Figure 7: Removal of objects / packaging material in the lane.

Note: Detailed information on potential malfunctions and their cause as well as solutions for troubleshooting can be found in the table on pages 38 - 39 and from page 44. Please refer to phases 1-3.

Cleaning



Figure 8: Cleaning tasks

Note: Detailed information on how to use the Access Kit for cleaning tasks can be found on page 44, Phase 2.

Maintenance and repair

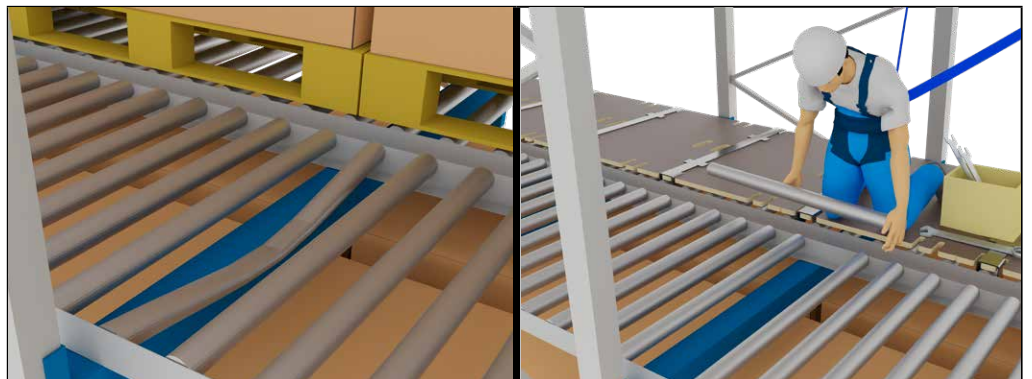
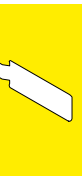

Figure 9: Using maintenance and repair tips - Comparing problem and solution

Note: Detailed information on how to use the Access Kit for maintenance and repair work can be found on page 44, Phase 2.

11 Troubleshooting chart for handling pallets that disrupt the workflow

The most common errors involve pallets which do not move forwards independently. The causes of such errors can be varied. The following section provides an overview of potential errors and causes which may be responsible for pallets not moving forwards independently. It also provides an overview of the fault resolution phases.



No.	Reason	Error	Description	Reason	Examples
	YES	Pallet does not move forwards	Pallet is somewhere in the lane and does not move forwards	Minimum weight not reached	Europallet: min. 100 kg Wire-mesh box pallet
				Defective pallet	Protruding elements Broken skid Defective or missing block Detached nails Projecting board Load carrier does not meet basic standard
				Poor pallet condition	Wet Dirty
				Foreign objects	Wood Cardboard boxes Foil LOADS
				LOADS	Uneven load Overloaded Too high Shifted Torn carton Insufficiently secured
2	YES	Pallet passes through lane	Pallet collides with strut/load separator/other component	Defective pallet	Protruding elements Broken skid Defective or missing block Detached nails Projecting board Load carrier does not meet basic standard
				Poor pallet condition	Wet Dirty
				Foreign objects	Wood Cardboard boxes Foil LOADS
				Defective in-feed guides	Improper assembly Pallet collides with FlowStop axle Pallet collides with another component
				Operator errors	Pallet stored off centre
3	YES	Pallet moves too quickly	Pallet moves forwards with an average speed exceeding 0.30 m/s	Defective component	Defective brake roller
				Improper pallet type	Load carrier does not meet basic standard
				LOADS	Pallet overloaded
				Oils/fats	Oils/fats under skids/blocks/boards
4	YES	Pallets not separated at picking position	Functionality of load separator is not guaranteed	Defective component	Defective load separator
				Improperly overhanging load	Europallet load overhang exceeds 1200 mm
				Dusseldorf/Halbe Europallets	Foil wrapping around pallets is insufficiently tight
				Operator errors	Pallet retrieved is too high (>100 mm). Pallet pushed back into rack from picking side Fork lift does not reverse directly backwards until the fork has left the rack.
5	No	Fault not visible	Pallet is in lane. The fault type cannot be seen from the floor.	See errors no. 1 and 2.	See errors no. 1 and 2.

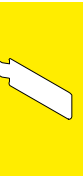

Fault resolution	Phase 1	Phase 2	Phase 3
Correct pallet weight	✓		
Correct cause of fault or take pallet out of use	✓	✓	
Take the pallet out of use Dry pallet Clean pallet	✓	✓	
Remove foreign object(s)	✓	✓	
Repack pallet	✓	✓	

Correct cause of fault Take pallet out of use		✓	✓
Take the pallet out of use Dry pallet Clean pallet		✓	✓
Remove foreign object(s)		✓	✓
Take the pallet out of use Initiate repairs		✓	✓
Train staff			

Replace brake roller		✓	
Take pallet out of use			
Correct loading error			
Clean load carrier/rollers. Locate and resolve source of fault		✓	

Repair/replace load separator		✓	
Correct loading error			
Tightly lash pallets together			
Comply with standard retrieval process; see "LIFO retrieval"			

Correct cause of fault See errors no. 1 and 2.		✓	(✓)
---	--	---	-----



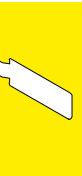

12 Instructions and work equipment

12.1 General information

Please note the exact sequence of steps.
 The PLS Access Kit is used exactly the same way with first in, first out (FIFO) and last in, first out (LIFO) systems. The PLS Access Kit can be used from the loading side or the picking side.
 When using the PLS Access Kit, all applicable national regulations, labour regulations and accident prevention regulations must be observed.

The PLS Access Kit must only be used with pallet live storage and push-back racking from BITO.

One person is required for Phase 1 (to operate the fork lift truck). At least two people are required for Phase 2 and 3.

Make sure not to damage the conveyor rollers in any phase.

Please observe all safety notices at all times.



DANGER!

Risk of falling from heights
 Racking levels with no railing, conveyor rollers can move
 Only access storage levels with an aerial work platform
 Do not walk on conveyor rollers



12.2 Troubleshooting notes

WARNING!

Danger of crushing
 Pallets move independently after the fault is corrected
 Fix all pallets in place within the lane

12.3 Cleaning notes

Clean the rack without using water or other liquids. We recommend sweeping, brushing, cleaning with a cloth or vacuum-cleaning.
 The most important cleaning task is to remove dust and foreign objects.

CAUTION!

Corrosion damage
 Do not use water
 Do not use cleaning substances
 Do not use pressure washers



12.4 Instructions on maintenance and repair

Maintenance and repair work must only be performed by qualified BITO technicians!

12.5 Instructions on personal protective equipment

BEWARE!
Always wear protective clothing when working with the rack.



Safety equipment to be worn:

- Personal protective equipment to prevent falls (PSAgA):
- Hard hat as specified in BS EN 397:2012, BS EN 50365:2002
- Safety shoes as specified in BS EN ISO 20346
- Protective gloves as specified in BS EN 420, BS EN 388
- High-visibility clothing as specified in with BS EN ISO 20471
- Safety equipment including body harness and double hook fall arrester
- Suitable work clothes

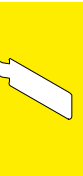

Figure 10: Body harness as specified in BS EN 361:2002*



Figure 11: Double hook fall arrester IKAR HWB 1.8 DW*

* For more detailed information on the body harness and double fall arrester, see pages 58 and 59.



12.6 BITO FallPROtect joining and lifting equipment

The BITO FallPROtect* set consists of BITO easyHOOK metal fixing hooks to be inserted into the upright slots and twist-lock carabiners in line with DIN EN 362.



Figure 12: Correct fastening of the BITO FallPROtect set including BITO-easyHOOK and twist-lock carabiner to an upright

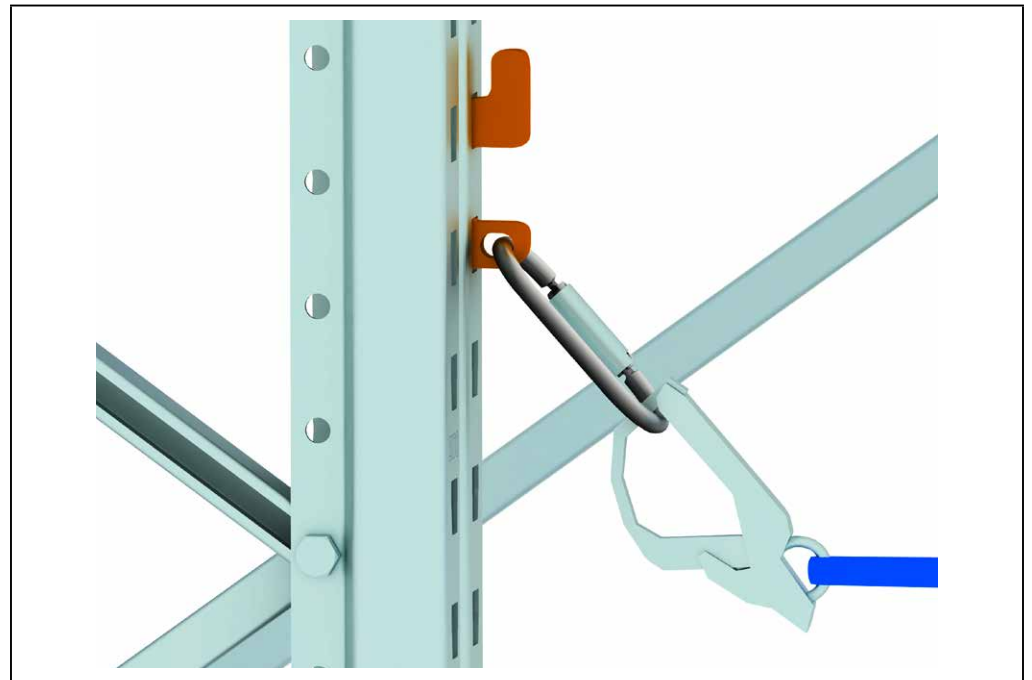







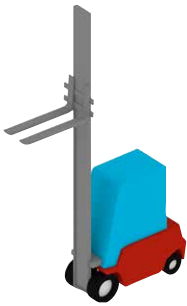
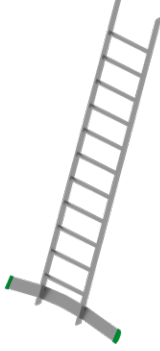
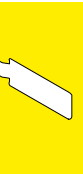

Figure 13: Correct use of the BITO FallPROtect set with attached double fall arrester IKAR HWB 1.8 DW

12.7 General accessories, work equipment and tools

			
<p>Traffic cone</p>	<p>Hard hat with headlamp</p>	<p>Pallet blocking device „light-duty“</p>	<p>Pallet blocking device „heavy-duty“</p>
			
<p>Crowbar</p>	<p>Locking profile for Flow-Stop load separator</p>		
<p>Walk-on boards to cover roller lanes</p>			
 <p>Forklift truck as specified in TRBS 2121-4*</p>		 <p>Ladder</p>	



* For detailed information on forklift trucks and working platforms (maintenance basket, scissor lift, etc.), please see page 58.

13 Fault correction phases

In the following, the use of the Pallet Access Kit is illustrated on the example of troubleshooting. Phases 1-3 are relevant in this case. For cleaning, maintenance or repair work, only steps 1-14 of Phase 2 are relevant. You would choose the shortest access path, depending on where the disturbance is located in the lane (either closer to the retrieval side or closer to the replenishment side). If the disturbance is located in the middle of the lane, it is up to the staff from which side they want to access the blocked pallet. If the fault can be resolved from the replenishment side, the neighbouring lane which serves as access lane does not need to be fully cleared: it only needs to be cleared up to the position of the fault.

13.1 Phase 1

First, check whether the pallet that got stuck in the lane will move again using any of the following measures.

FIFO systems:

1. Feed in a pallet carrying approximately 75% of its maximum load capacity and see whether it pushes the blocked pallet forward again.

LIFO systems:

1. Fill the lane from the replenishment side
2. Carefully push the blocked pallet backwards
3. Allow the pallet group to move forward again.

If the blocked pallet still does not move forward, proceed to resolve the fault as described in Phase 2.

13.2 Phase 2

1. Secure the replenishment and retrieval areas of the workspace.

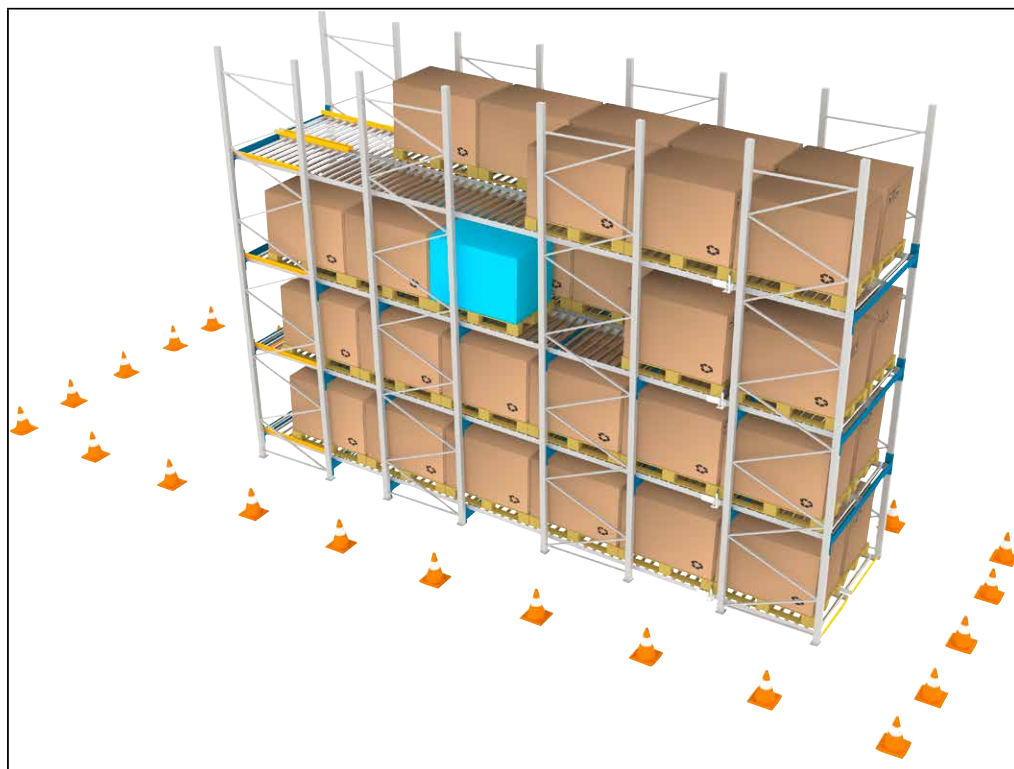
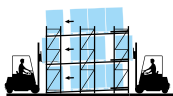

Figure 14: Securing the workspace (e.g. using traffic cones)

FIFO



LIFO



2. Use a forklift truck to retrieve all pallets from the lane adjacent to the lane where the fault is located or from the lane where the cleaning, maintenance or repair work is taking place.

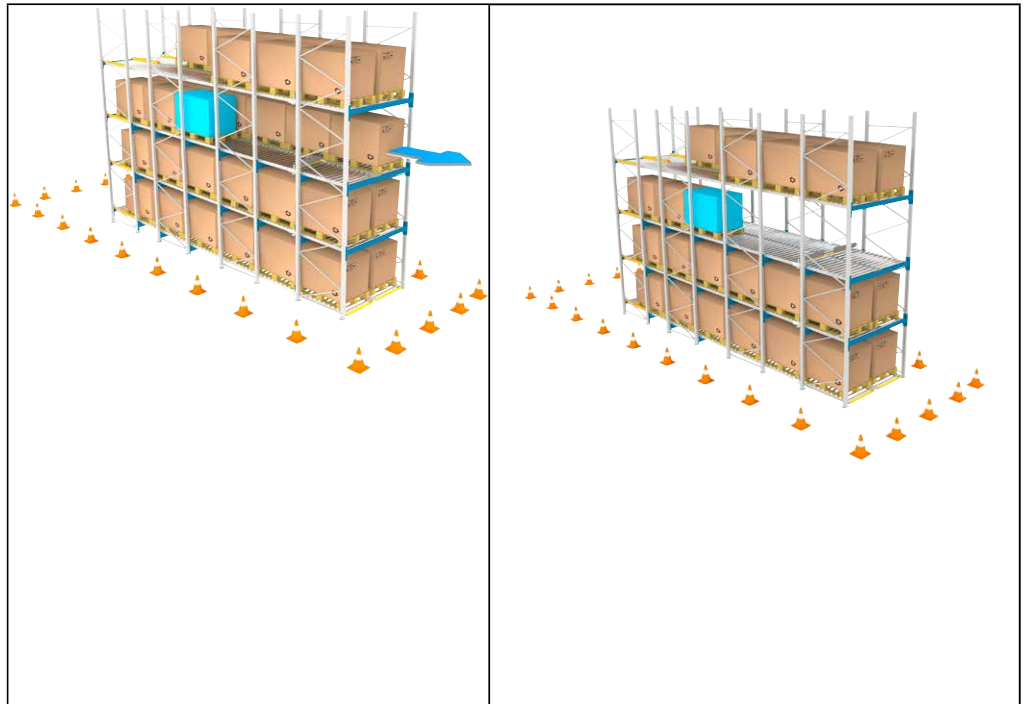
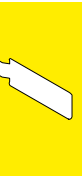

Figure 15: Removing pallets from the neighbouring lane





- 3a. Check whether all pallets also need to be removed from one of the lanes above the lane where the fault is located. Check the year of construction on the racking capacity sign. If the racking has been set up before 01/2019, observe the following points 3b and 3c, otherwise continue with point 4.
- 3b. Proceed as follows:
 - (i) Check the racking capacity sign for your load carrier type(s), the storage direction and the maximum load carrier weight.

(ii) Determine the “t” measure on the picking side of the rack (see figure 16).

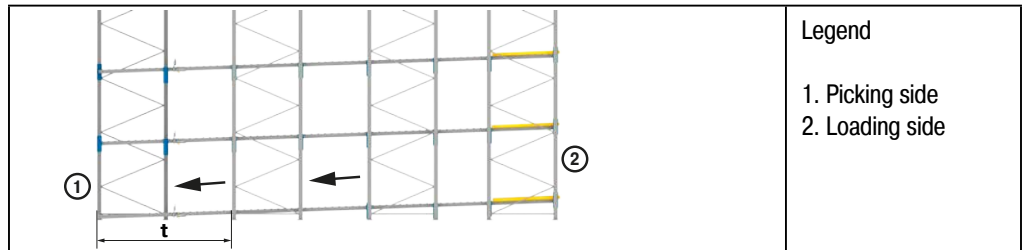

Figure 16: Pallet live storage system including “t” measure (side view)

iii) Find “t” for your load carrier type and storage direction in the table below.

	X	Y
Euro pallet stored short side facing	Single-lane bays only	All other configuration options
2500 mm > t ≥ 2200 mm	≥ 1090 kg	≥ 730 kg
t = 2,500 mm	≥ 960 kg	≥ 640 kg
Industry pallet or CHEP pallet stored short side facing	Single-lane bays only	All other configuration options
2500 mm > t ≥ 2200 mm	≥ 1090 kg	≥ 730 kg
t = 2,500 mm	≥ 960 kg	≥ 640 kg
Euro pallet stored long side facing	Single-lane bays only	All other configuration options
2500 mm > t ≥ 2200 mm	≥ 750 kg	≥ 500 kg
t = 2,500 mm	≥ 700 kg	≥ 440 kg
Industrial pallet/CHEP pallet stored long side facing	Single-lane bays only	All other configuration options
2500 mm > t ≥ 2200 mm	≥ 920 kg	≥ 620 kg
t = 2,500 mm	≥ 810 kg	≥ 540 kg
Düsseldorf/Heilbronn pallet stored short side facing	Single lane bays only	All other configuration options
2500 mm > t ≥ 2200 mm	≥ 590 kg	≥ 390 kg
t = 2,500 mm	≥ 520 kg	≥ 350 kg
Mesh-box pallet stored short side facing	Single-lane bays only	All other configuration options
2500 mm > t ≥ 2200 mm		≥ 390 kg
t = 2,500 mm	≥ 910 kg	≥ 350 kg

Table 8 : Check whether another lane needs to be cleared.

- iv) Select the row matching your “t” value (see table 8 above).
- v) If your racking installation only consists of single-lane bays, read the value in column X. For all other systems, read the value in column Y.
- vi) If the maximum load carrier weight specified on the racking capacity sign is **greater** than that specified in the table, there is no need to clear any other lane.

If the specified maximum load carrier weight is **smaller**, you will need to clear another lane (see item 3c).
 3c. If it is necessary to clear another lane, clear a lane above the lane where the fault is located.

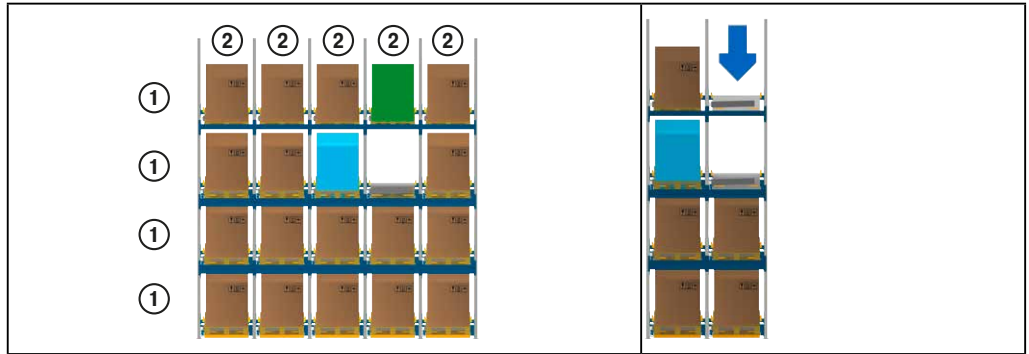

Figure 17: Removing pallets from a lane above the neighbouring lane, using the example of a single-lane bay. Legend: (1) Storage level, (2) Bay

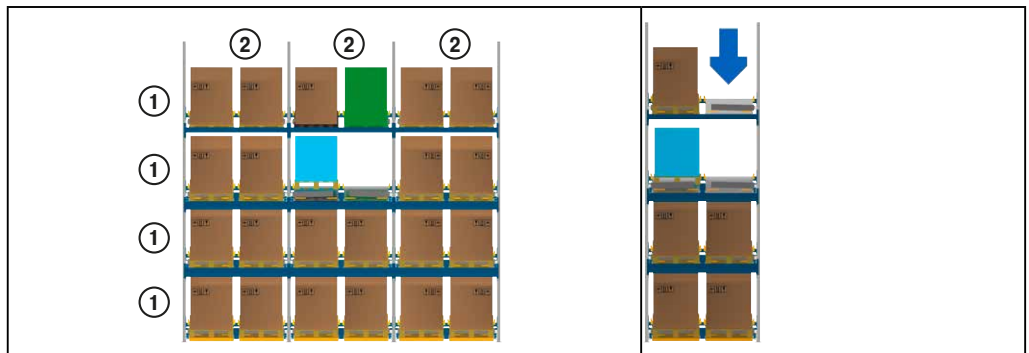

Figure 18: Removing pallets from a lane above the neighbouring lane, using the example of a double-lane bay. Legend: (1) Storage level, (2) Bay

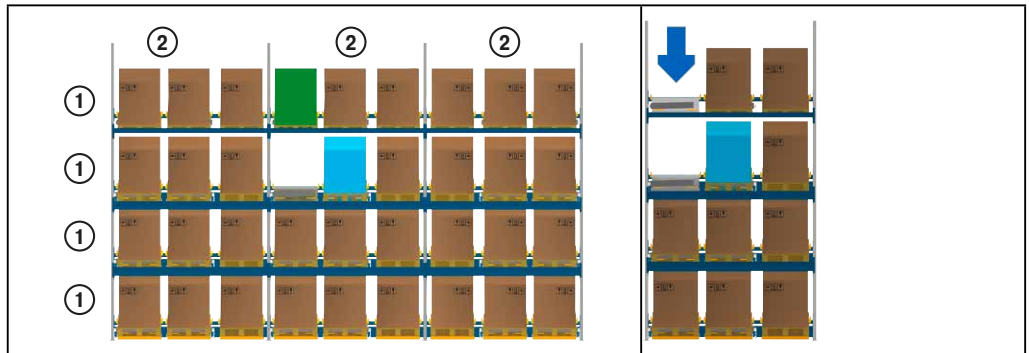
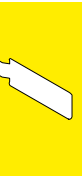

Figure 19: Removing pallets from a lane above the neighbouring lane, using the example of a triple-lane bay. Legend: (1) Storage level, (2) Bay

Blocked lane

Lane where pallets may be retrieved



4. Climb into the neighboring lane using a suitable ladder.

CAUTION!
Keep your hands away from hazard zones

- a. The ladder must have a sufficient length, load capacity, and base width.
- b. The ladder must comply with EN 131 and be approved for professional use.
- c. The top three rungs of the ladder must not be climbed; take this into account when selecting the ladder.
- d. All ladders must be inspected for damage before use and replaced or repaired if damage is detected.
- e. All ladders must be inspected for excessive dirt before use and cleaned accordingly.



Figure 20: Ladder

5. Secure yourself with the BITO easyHook at head height on the first upright.

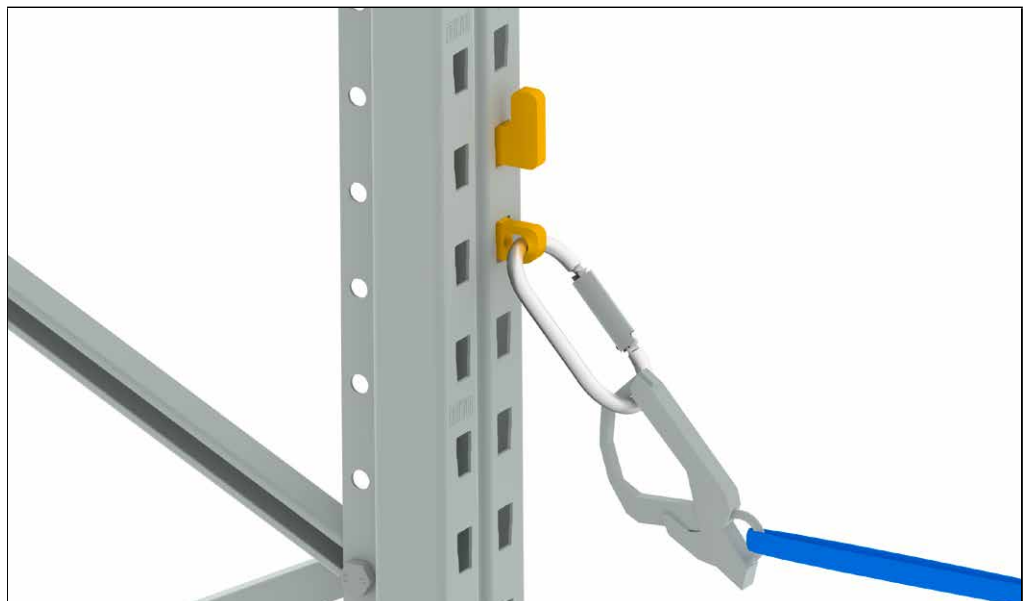

Figure 21: Fix BITO easyHook to upright

6. Place the first board in the adjacent lane. Secure the board to a suitable load-bearing roller, ensuring that the U-profile of the board does not interfere with other parts of the roller conveyor.

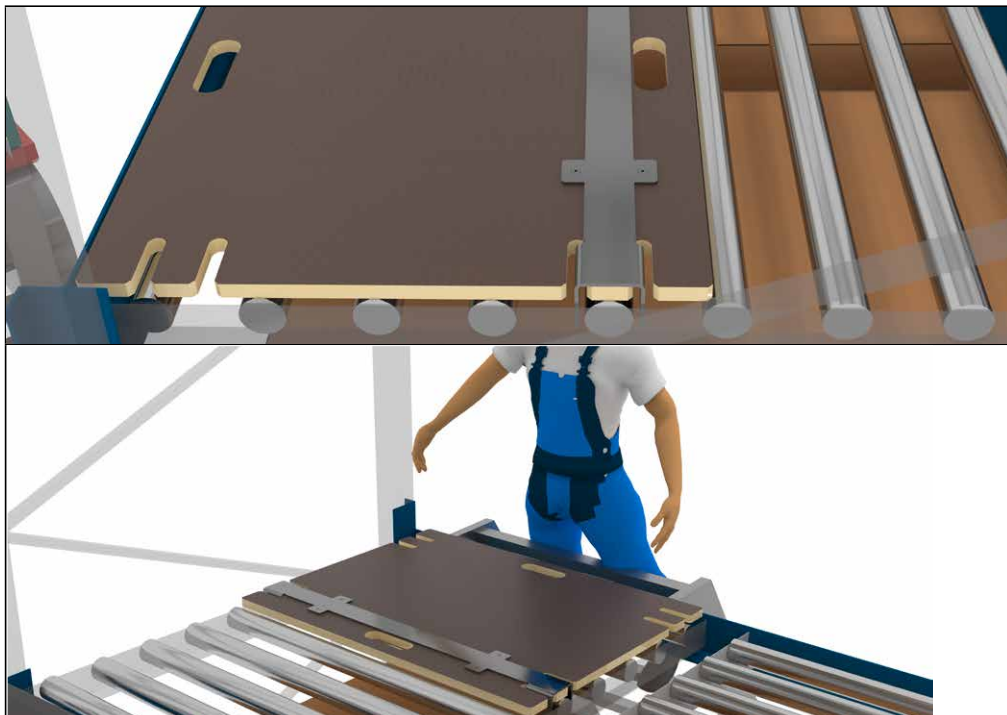

Figure 22: Placing a walk-on board into lane

7. Step from the access platform onto the board.



Figure 23: Accessing the lane

8. Rotate the FlowStop flag of the load separator to the lane side (only required in FIFO system).

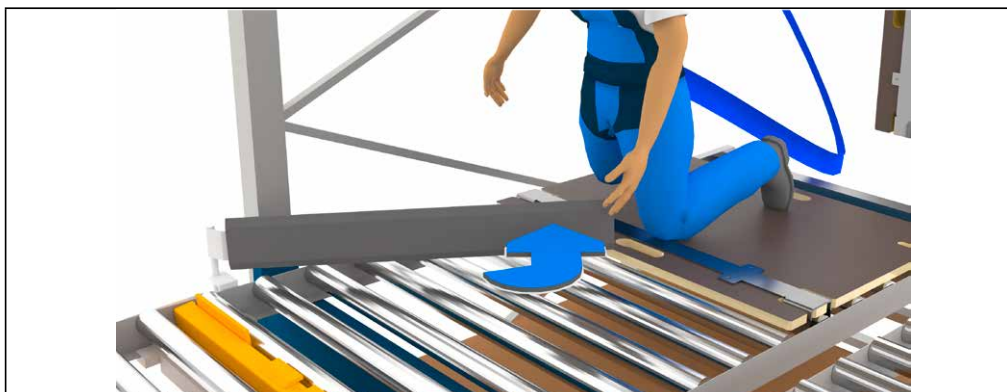
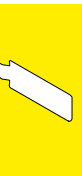

Figure 24: Rotating the FlowStop flag to the side



9. Secure the FlowStop activator using the BITO holding device.

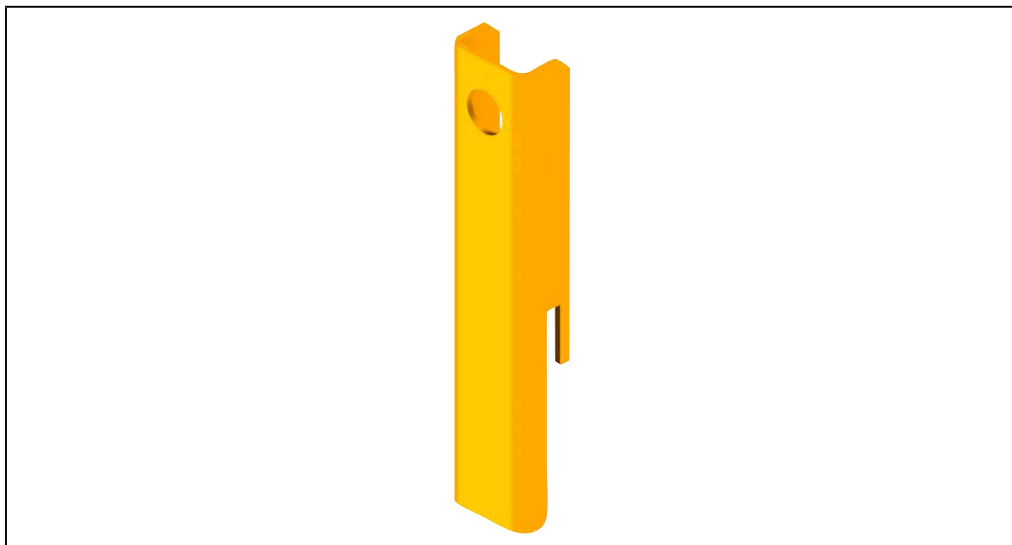

Figure 25: BITO holding device

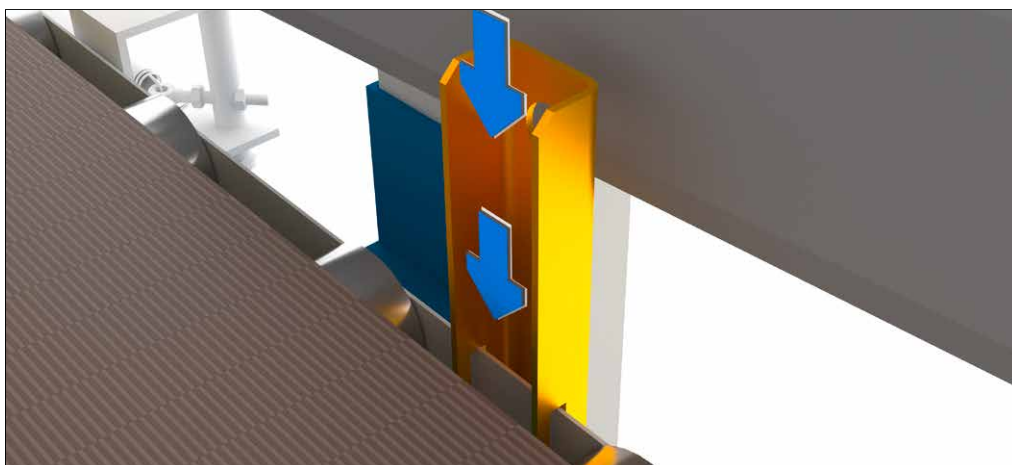

Figure 26: BITO holding device

10. Place as many connecting boards in the lane as needed to reach the trouble spot. Ensure that all boards are securely fastened together.



Figure 27: Placing connecting boards

11. Walk on the connecting boards in the neighbouring lane, using the fall protection equipment, until you reach the blocked pallet. Do not step on the rollers.

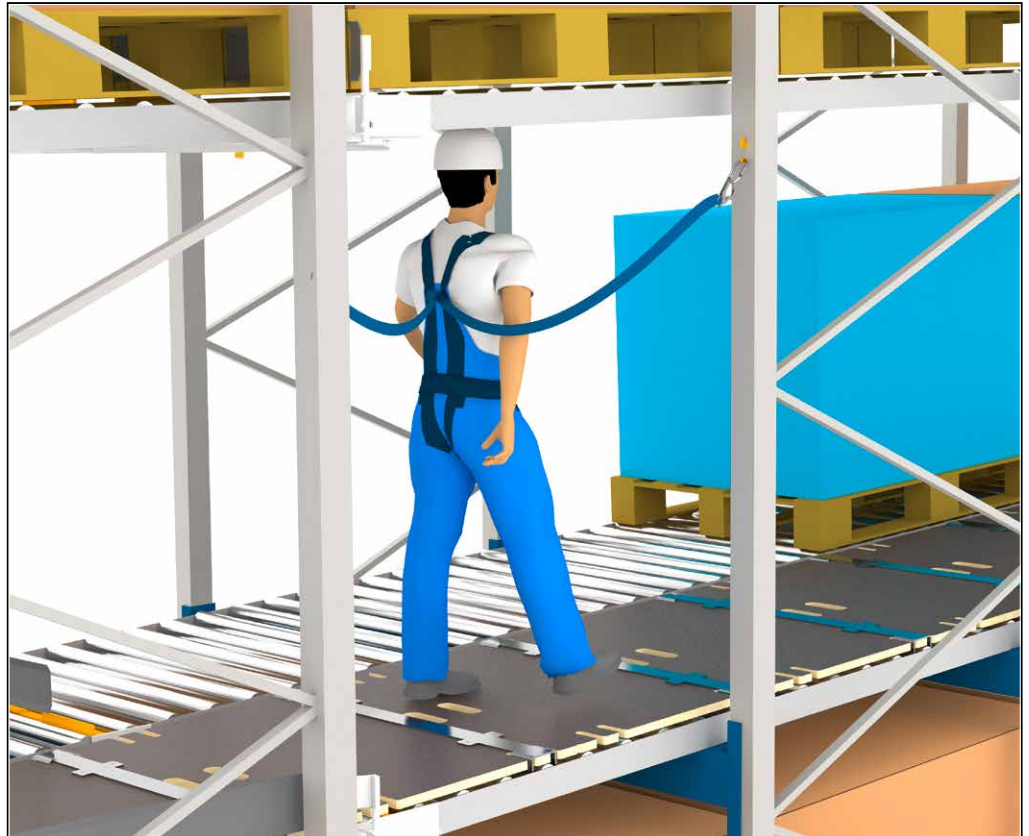
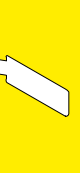

Figure 28: Person walks to blocked pallet





12. Secure the stuck pallet with the heavy-duty blocking component. Maximum load 15 t (15,000 kg).

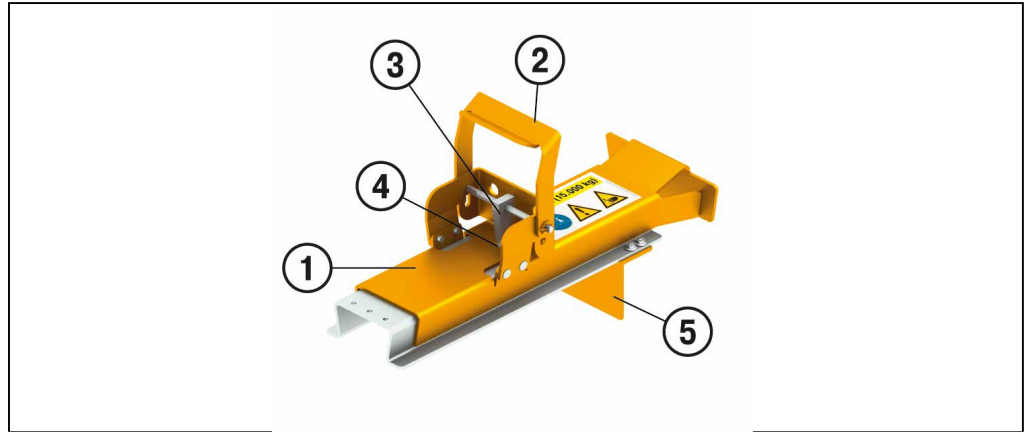
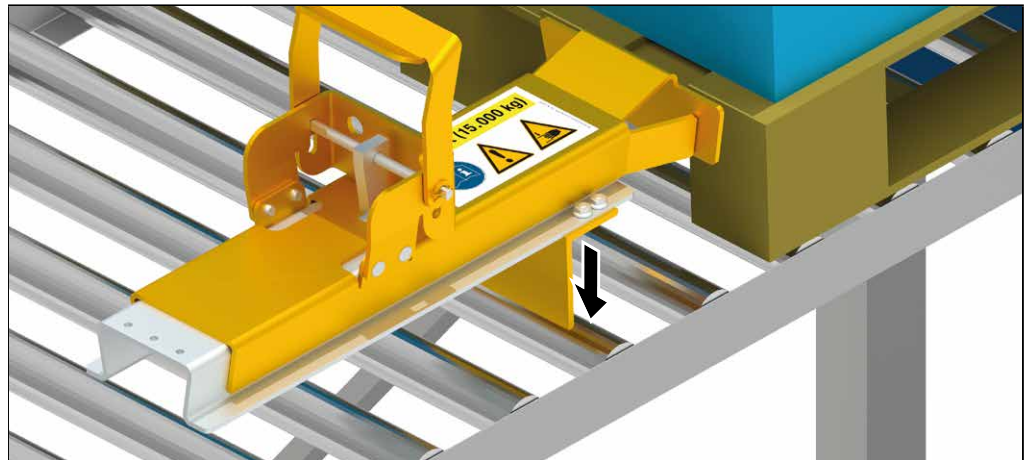

Figure 29: Components of heavy-duty blocking device

Legend heavy-duty blocking device

- 1. Skids
- 2. Handle
- 3. Wedge
- 4. Rectangular hole
- 5. Angled holder

a) Place the heavy-duty blocking device in front of the faulty pallet so that ...



b) ... the angled profile (5) is braced against a roller

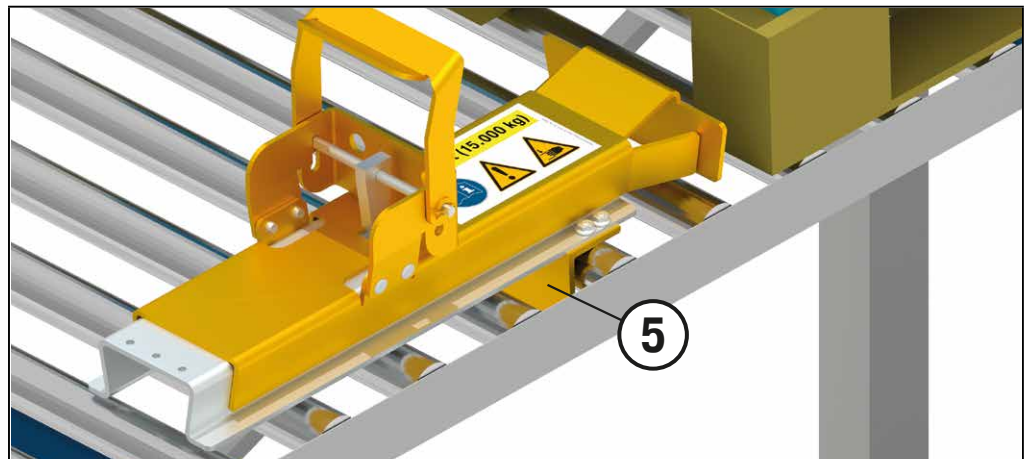

c) Move the skids (1) as close as possible to the faulty pallet. Make sure not to place your hands or any part of your body between the faulty pallet and the blocking device.

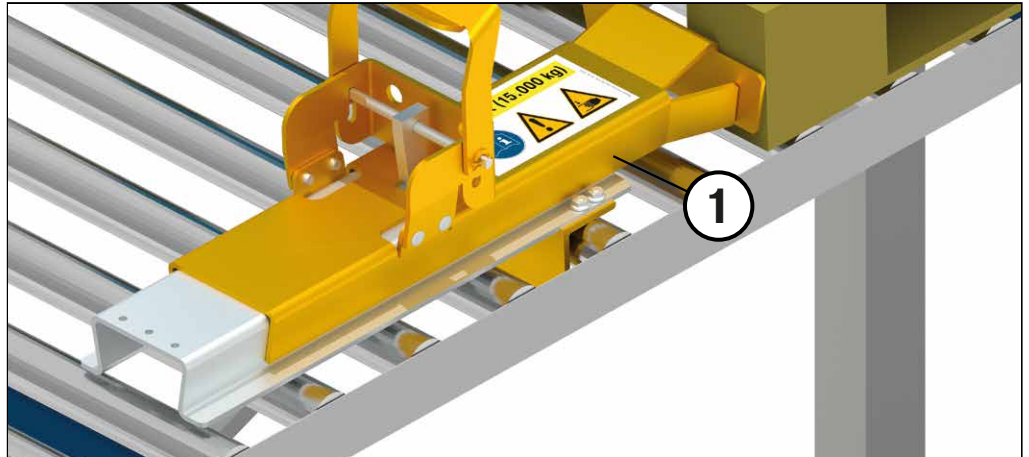

d) Use the lever to move the wedge (3) into its resting position until the lever has fully rotated backwards.

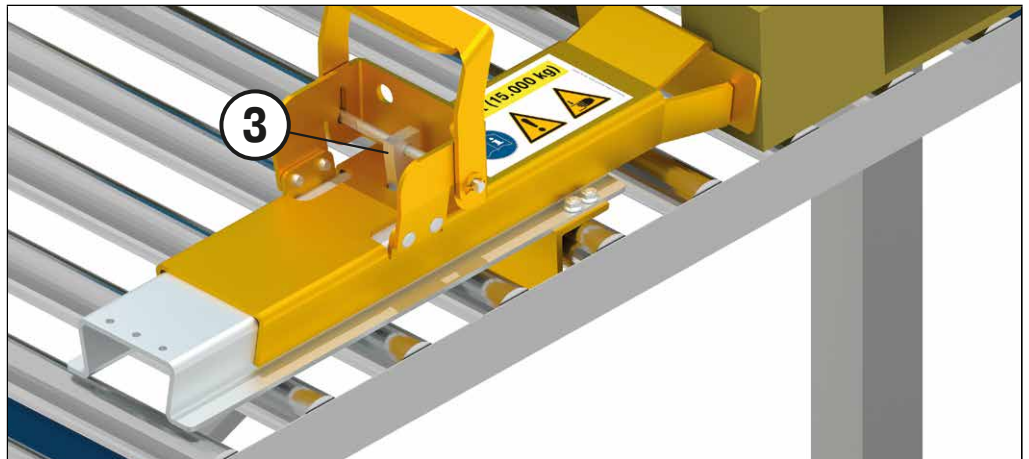

e) Fold the handle (2) down by 90°.



f) The faulty pallet is now secure.



13. Determine the cause of the fault.
14. Do not step on the roller conveyor.
15. If possible, correct the issue that caused the fault.
 - a) Cause can be corrected -> Continue to item 22.
 - b) Cause cannot be corrected -> Resolve the fault as described on page 56 in Phase 3
 - c) Cause cannot be corrected due to a defective component. Initiate repairs with BITO construction specialists.
16. If possible, position the pallet centrally and angle it straight ahead.
27. Remove the heavy-duty blocking device.
 - a) Detach the heavy-duty blocking device by folding back the handle (2).

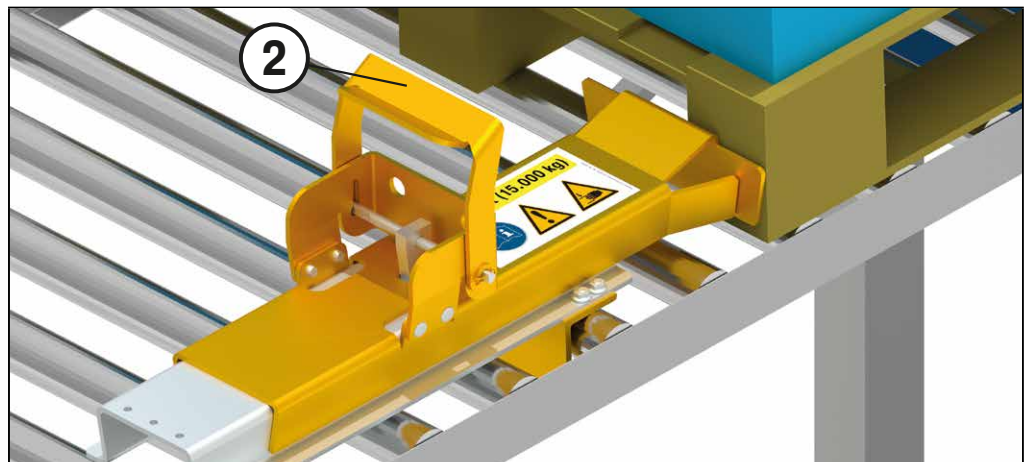

- b) Remove the wedge (3) by pulling firmly on the handle.



c) Remove the heavy-duty blocking device.

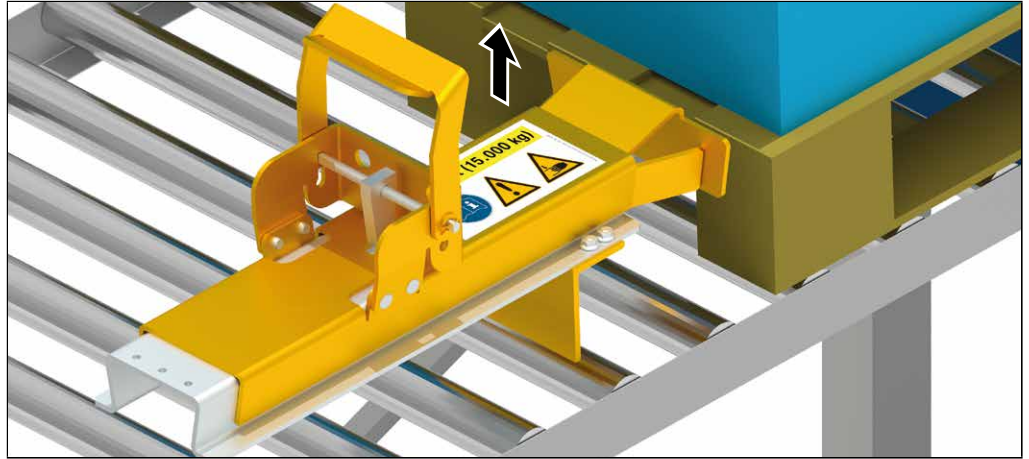

18. The faulty pallet (and the other pallets) should now move smoothly again.
19. Pick up all foreign objects and tools.
20. Using the fall protection equipment, remove the boards from the neighbouring lane.
21. Remove all safety elements (e.g. traffic cones) from the retrieval and replenishment areas.
22. Return the pallets to the cleared channels.
23. The system is now ready to use again.

13.3 Phase 3

1. Using the fall protection equipment, place an empty replacement pallet (1) in front of the faulty pallet.

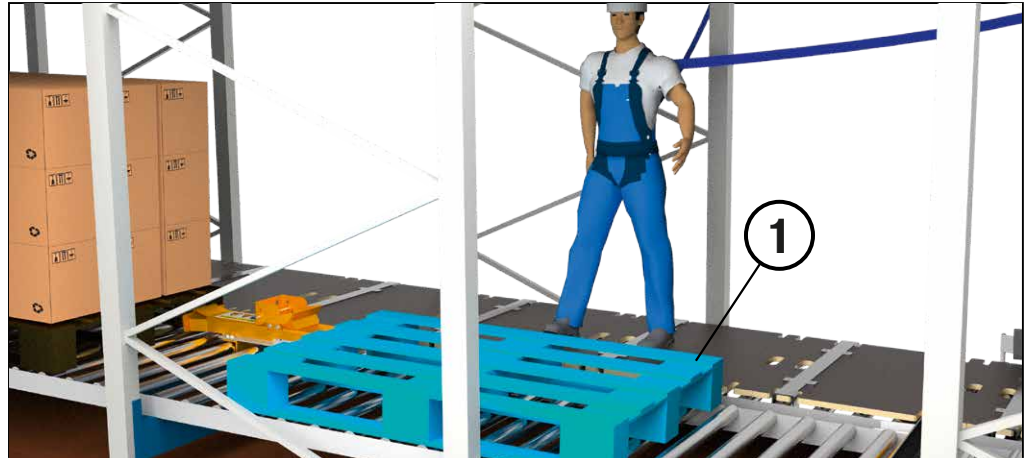

2. Secure the empty replacement pallet (1) with the light-duty blocking device (3). Maximum load 1.5 t (1,500 kg).

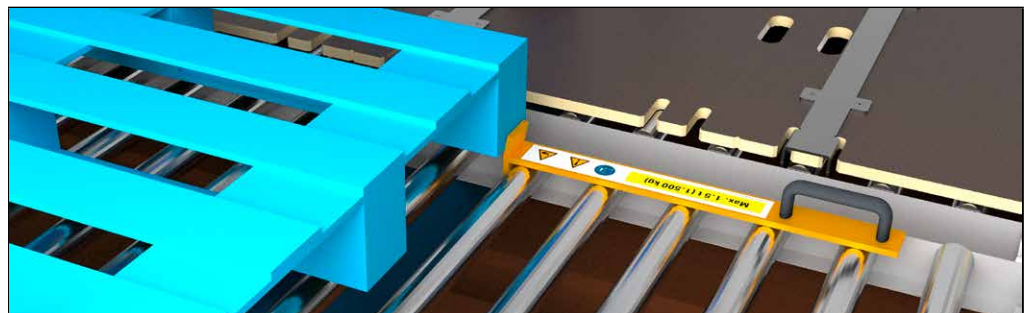

3. If possible, position the pallet (1) centrally and angle it straight ahead.

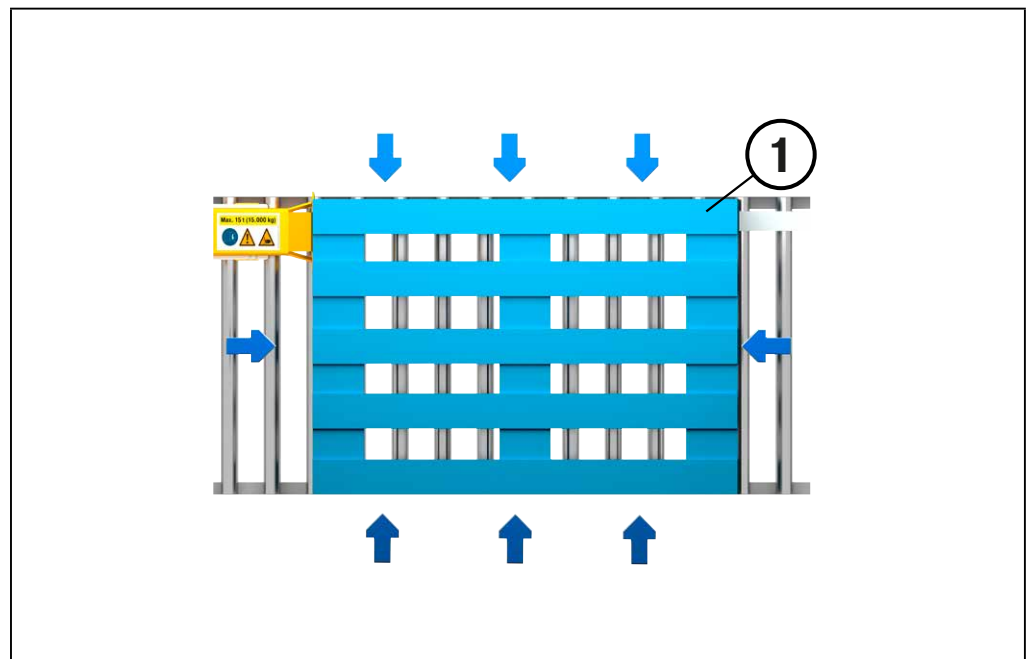

4. Move the load from the faulty pallet (2) to the replacement pallet (1).

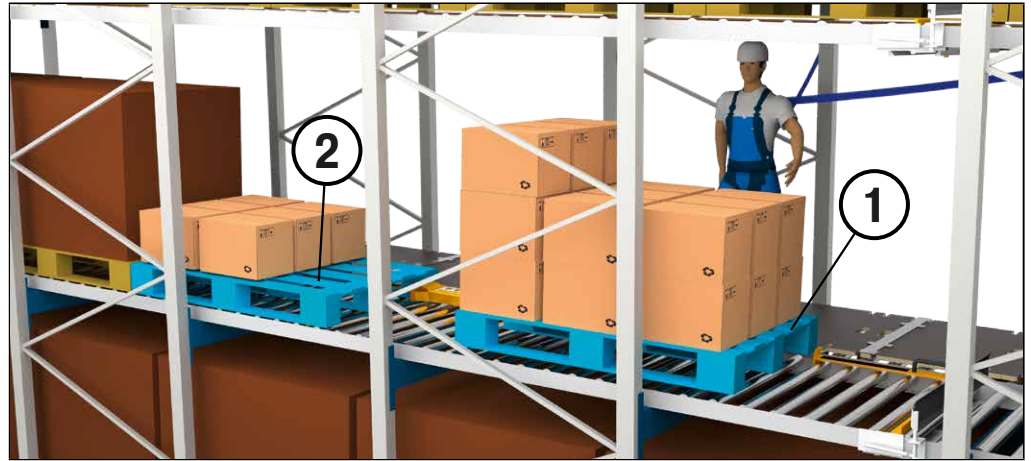

5. Remove the light-duty blocking device. The replacement pallet should now move smoothly to the retrieval side.
6. If the fault is now resolved, remove the heavy-duty blocking device in front of the faulty pallet (see item 17, Phase 2).
7. If the fault remains, remove the unloaded faulty pallet (2) from the faulty lane, using fall protection equipment. The blocking device must be removed. The user will only have about 4 seconds to do this. If the blocking device is not removed, the heavy impact could damage the device and the roller conveyor.
8. Follow the instructions under Phase 2, no. 19.

14 Detailed notes on work equipment, tools and protective equipment to prevent accidents

14.1 Notes on the double fall arrester



Figure 30: IKAR double fall arrester (TYPE: HWB 1.8 DW)

Always follow the instructions provided for the IKAR double fall arrester (TYPE: HWB 1.8 DW). Always keep the inspection log together with the equipment itself. If the inspection log is lost, you will no longer be able to perform annual tests. Using a device without proof of annual testing leads to danger of death! Please note that two people must not be attached to the same racking upright.

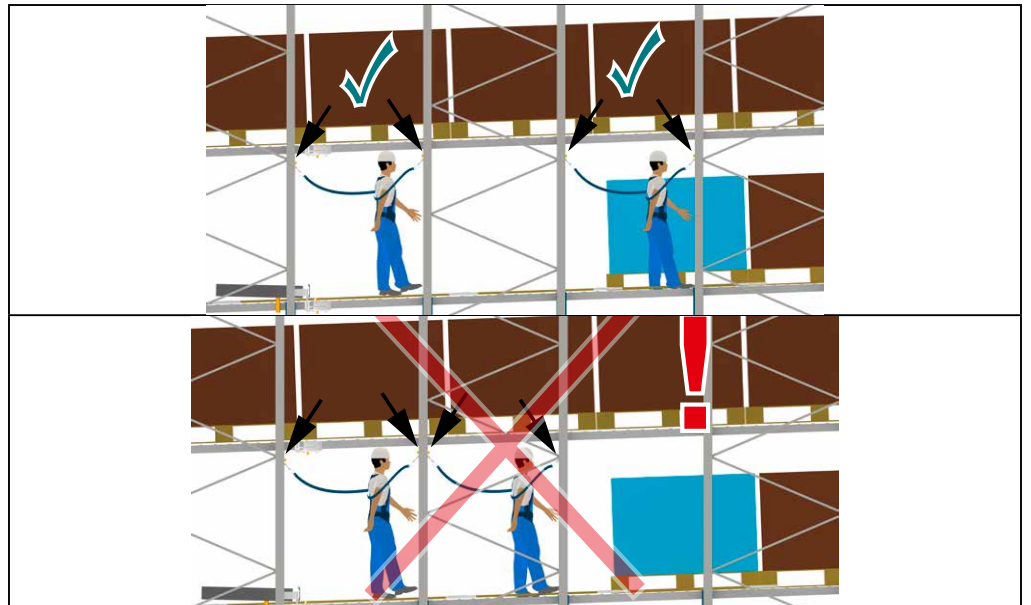

Figure 31: Correct use of double fall arrester

Please note that two hook clamps from the double fall arrester must never be attached to the same twist-lock carabiner.

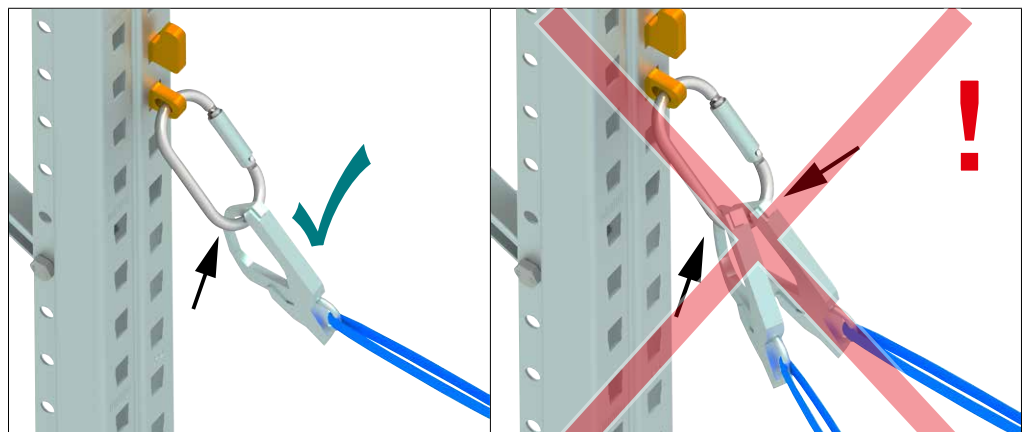

Figure 32: Using the double fall arrester with the twist-lock carabiner.

14.2 Notes on the body harness



Figure 33: Body harness as specified by BS EN 361:2002

Use IKAR Auffanggurt IK G 2 B Pad body harness or a body harness with comparable technical specifications.
Ensure that the body harness is securely attached to your body.
Perform a visual check before each use.

The safety harness must be worn snugly. As a rule of thumb, it should fit so tightly that no more than one finger can fit between the body and the safety harness. If the harness is worn too loosely, there is a risk of serious cuts or lacerations in the event of a fall.

The instructions for use of the safety harness must be strictly observed. Always keep the inspection log with the equipment. If the inspection log is lost, annual inspections can no longer be carried out. Using a safety harness without proof of annual inspection poses a risk to life!

Follow all other instructions provided by the manufacturer!

14.3 Notes on board care and storage

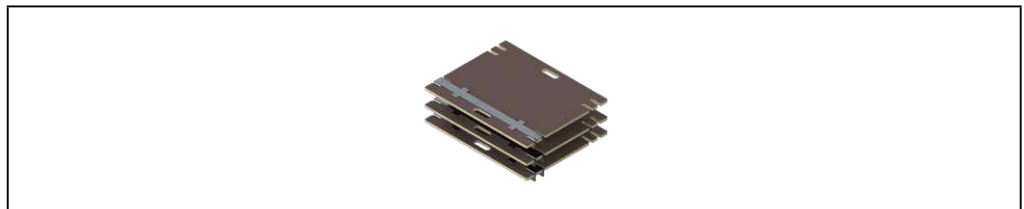

Figure 34: Walk-on boards for safe access into a lane

Notes on care and storage:

BITO boards must be kept clean, dry and protected against weather. Store BITO walk-on boards in a clean, dry place protected from adverse weather conditions. Wood is a natural material that can warp under the influence of environmental conditions such as moisture, temperature fluctuations, sunlight, etc. This effect is even more pronounced in plywood boards than in solid wood, as the gluing of the various veneer layers in plywood can cause internal stresses, which are further exacerbated by external influences. There is therefore no guarantee that warping will not occur. The storage and cleaning recommendations must be strictly adhered to!

14.4 Notes on annual inspection

Pursuant to BGR 198 / BGR 199 personal fall protection equipment (BITO-easyHook, twist-lock carabiner, body harness, fall arrester, hard hat) must be inspected every 12 months. For further details on inspection refer to www.bitocom.com or:

Ingenieurgesellschaft AJP GmbH
Mendelstraße 11
48149 Münster
info@a-j-p.de
Tel.: +49 (0) 251 26 52 910
Fax: +49 (0) 251 68 65 332

15 BITO-FallPROtect manual and inspection log

Anchor device type B conforming to DIN (ÖNORM/SN) EN 795:2012-10 Type BITO FallPROtect Capacity 9 kN – 1 person	
Product description: BITO FallPROtect Anchor device type B conforming to DIN(ÖNORM/ SN) EN 795:2012-10 Manufacturer: BITO-Lagertechnik Bittmann GmbH ID of supervising office: CE 0158 Observe instructions of use	



15.1 Notes for safe usage

1. The BITO-FallPROtect anchor device has been tested and authorised for use to protect 1 person. It consists of 3 components:

BITO-easyHook, twistlock carabiner and racking upright.
2. The user must be trained in the safe use of the product, have read and understood the use and assembly instructions, and not have any physical conditions which could influence the user's safety (e.g. circulatory problems, medication, etc.)
3. There is a danger of death if these instructions are not followed. In case of a fall, the user must not be left hanging in the harness for more than 15 minutes, otherwise there is a risk of acute shock.
4. In case of an emergency when using this equipment, a rescue plan must be in place taking into account all possible emergencies.
5. The inspection log supplied with this equipment should be fully filled by a specialist at first use and kept with the equipment for the entirety of its service life.
6. Before use, all components must be visually inspected for damage as a result of mechanical, chemical or thermal effects. If there are any doubts about the safety of the equipment's condition, it must be inspected by a specialist or by the manufacturer.
7. Damaged components, or those used as the result of a fall, must be removed after use. Changes or repairs must only be made by the manufacturer.
8. The equipment must be protected against contact with oils, acids, alkalis, solvents, open flames, liquid metal drops and sharp edges during use.
9. The equipment may only be used for its intended purpose, and not as an anchor point for load lifting or lowering equipment.
10. The anchor point to be used (racking upright) must have sufficient carrying capacity and be able to withstand a load of at least 9 kN in line with DIN (ÖNORM/SN) EN 795.
11. If the equipment is resold in another country, the reseller must include these instructions, with all details provided in the language of the country in question.
12. No changes or additions may be made to the equipment without prior written authorisation from the manufacturer.

15.2 Technical safety requirements for fall arrest systems and assembly

1. If you are using additional personal protective equipment to protect against falling, ensure that this equipment is compatible. Follow all instructions given for this additional equipment.
2. A fall arrest system may only use a body harness complying with DIN (ÖNORM/ SN) EN 361, and there must always be a shock-absorbing element (fall arrester, company: IKAR, type: HWB 1.8 DW) to limit the high-impact forces involved with the fall arrest system to a maximum of 4.5 kN (including safety margin).
3. The anchor point should be positioned as high as possible and as close as possible to vertically above the user's work position (ideally over the head or below the beam) in order to limit the fall height to a minimum and prevent pendular movement in case of a fall.
4. The anchor device must only be used together with the fall arresters manufactured by IKAR (Type: HWB 1.8 DW).
5. Always ensure there is sufficient open space in the work area below the user to prevent them landing on the ground or another obstruction.

In unfavourable conditions (anchor point at standing height). Extension or combination with other anchor devices is not permitted. 2 connectors must never be used with the same shock absorber.

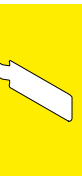



15.3 Assembly

The anchor point (BITO-easyHOOK) is connected to the racking upright as shown in figures 1-5. Pass the twistlock karabiner with automatic safety catch (twistlock) through the hole of the BITO easyHook (see picture 4). Ensure that the twistlock carabiner is fully locked. Make sure and check that the anchor point cannot accidentally come loose from the racking upright.

The anchor device, in combination with the fall arrester and a harness, now constitutes a safe fall arrest system (figure 5).

To disassemble the system, follow the instructions in reverse.

	<p>Anchor point (BITO easyHook)</p>	<p>1x</p>
	<p>Twist-lock carabiner</p>	<p>1x</p>



1



2



3



4

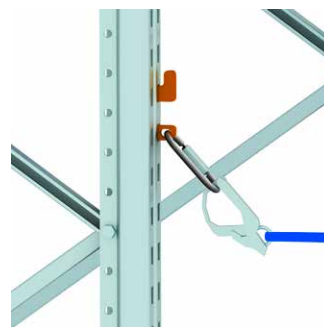

5

15.4 Storage / care

If the anchor point is not used, it should be transported and stored in clean, dry and airy conditions together with the twistlock carabiner. Both the anchor point and the twistlock carabiner are made of metal and must therefore be protected against external influences such as welding flames and sparks, fire, acids, alkalis and extreme temperatures (min. -20°C to max. 60°C) and water damage. They can be cleaned using a little warm water and a neutral cleaning agent. Wash away the remaining cleaning agent with clear water. Only dry them naturally: never use fire or other sources of heat. Disinfection measures may only be taken with the approval of the manufacturer.

Always comply fully with the storage and cleaning instructions!

15.5 Testing

The equipment must be inspected at least once every 12 months by a specialist or by the manufacturer! The inspection must be documented in the test log supplied with the equipment.

During the test, note the following points in particular:

- Product identifier (legibility)
- Check anchor point and twistlock carabiner for wear and tear, deformation, tears and breakage.
- Check the functionality of the twist lock carabiner. Material fatigue and damage to the belt of the body harness and the double fall arrester

The safety of the user depends on the effectiveness and durability of the equipment. Maintain compliance with DGUV 112-198 and DGUV 112-199.

15.6 Service life

Textile elements of the equipment such as belts (tethers, body harnesses, etc.) as well as ropes and straps (connectors, guided-type fall arresters with a flexible anchor line, slings, stopper lines, etc.) may be used under normal conditions for up to 8 years. The BITO easyHOOK anchor point with twistlock carabiner may initially be used under normal conditions for up to 10 years from the year of manufacture, provided it experiences no damage, wear or material alteration. Annual tests may be performed by a trained specialist in PPE to protect against falling in line with BGG 906. The equipment must be presented to the manufacturer for inspection after 10 years at the latest. The manufacturer may then decide to extend the equipment's service life.

15.7 Compatibility

The BITO-FallPROtect anchor device may only be used with the following BITO racking systems:

- PROflow pallet live storage / static pallet racking with racking upright types P2, P3, P4, P5, P6, P7, P8, P9, P9S, P12L, P12M, P12S

Always ensure that the rack is stable.

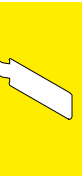

15.8 Evidence of periodic testing

BITO easyHOOK anchor device DIN (ÖNORM/SN) EN 795:2012-10 (Caution: All identifying information on each product must always be fully legible!)				
Manufacturing year	Serial/fabrication number	Purchase date	Date of first use	
Regular inspections/repairs (In line with DIN EN 365, the equipment must be checked at least once every twelve months!) Always keep the manual with the equipment. Request a copy from the manufacturer if required!				
Date	Reason for work 1 = regular inspection 2 = repair	Documentation of repairs/ damage identified	Name/Signature of specialist Punch	Date of next inspection
Your retailer:		Notes/special instructions:		
Office notified and appointed for the EU/EC type examination: DEKRA Testing and Certification GmbH, Dinnendahlstraße 9, 44809 Bochum				
Manufacturer: BITO-Lagertechnik Bittmann GmbH, Obertor 29, 55590 Meisenheim			Tel. +49 (0) 6753 122-0 Fax: +49 (0) 6753 122-399	

16 Repair

This chapter deals with repairs that may be carried out by qualified staff. Repairs not listed here may only be carried out by BITO-Lagertechnik Bittmann GmbH. Repairs that may be carried out by qualified staff:

1. Replace in-feed guide
2. Replace conveyor rollers
3. Replace brake rollers
4. Replace roller lane side sections
5. Fahne Replace FlowStop load separator

16.1 Qualified staff

Qualified repair personnel are those persons who can read and understand these instructions of repair and who can follow the operating instructions and the legal regulations. Additionally, qualified repair personnel require additional system-specific instruction.

16.2 Replace in-feed guide

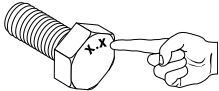







①		In-feed guide	2x
②		Bracket	4x
③		M8 x 20 mm DIN EN ISO 4017	4x
④		ø 8.4 mm	4x
⑤		M8 DIN EN ISO 4032	4x
⑥		M10 x 30 mm DIN EN ISO 4017	8x
⑦		M10 DIN EN ISO 4032	8x

Table 9 : List of in-feed guide parts

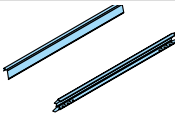
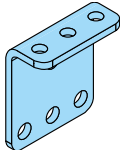

1. Dismount the damaged in-feed guide.
2. Fix the holders (2) to the frame (1) using screws (3), lock washers (4) and nuts (5) as shown in the following figure.

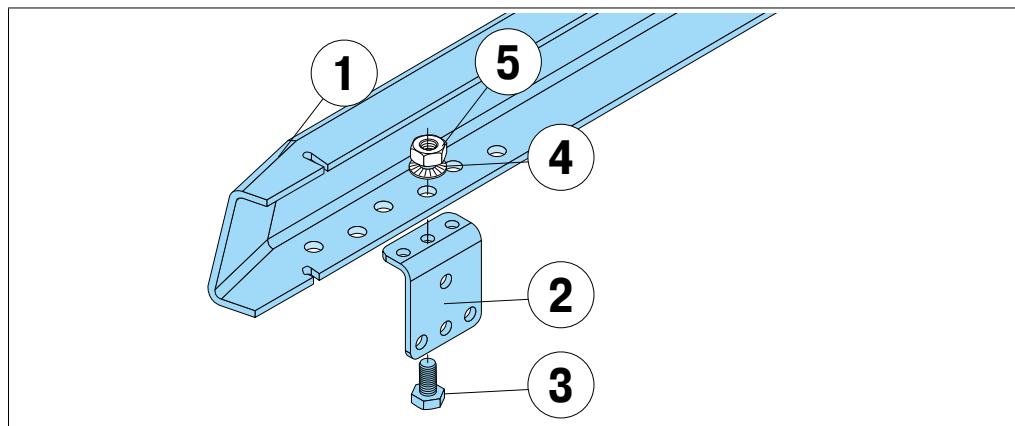
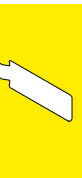
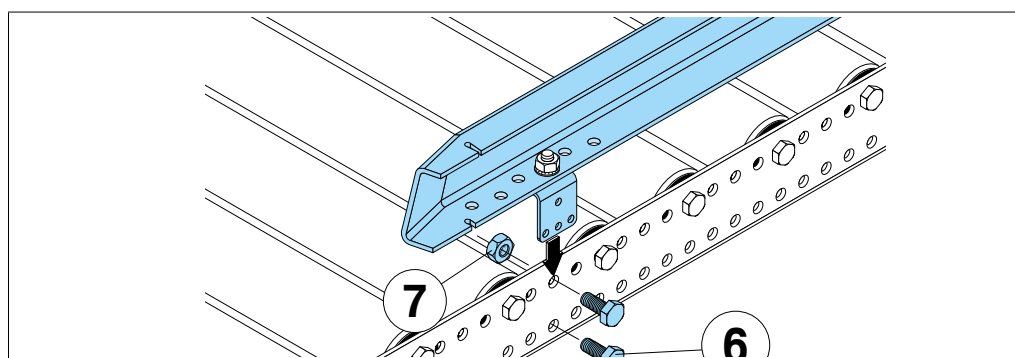

3. Fasten the in-feed guide to the roller conveyor using screws (6) and nuts (7) as shown in the following figure.

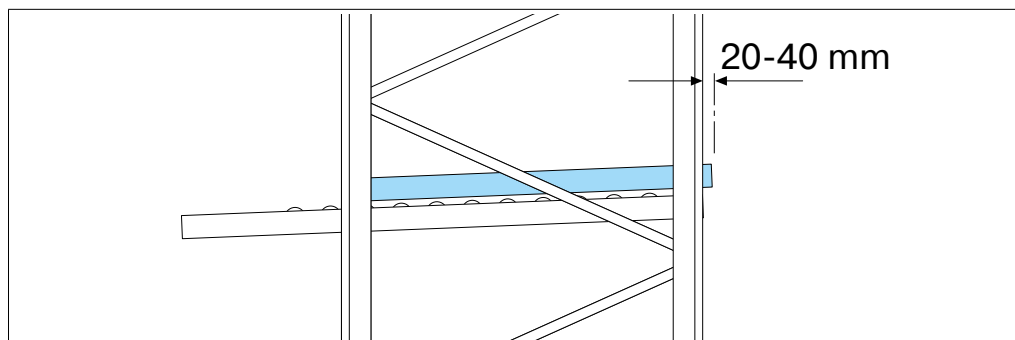

4. Place the in-feed guide on the roller conveyor lane so as to create a 20 - 40 mm projection over the front uprights.

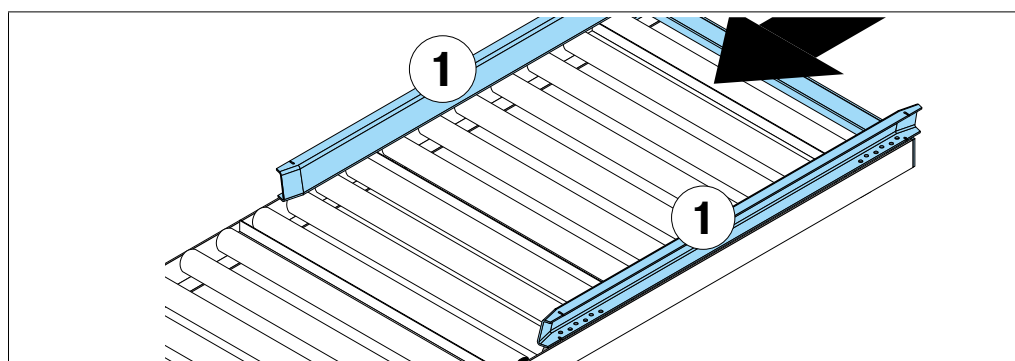

5. Fix the in-feed guide in positions A and B and observe the distances given in the following tables and figures. The in-feed guide must open towards the retrieval side.

16.3 Replace in-feed guide

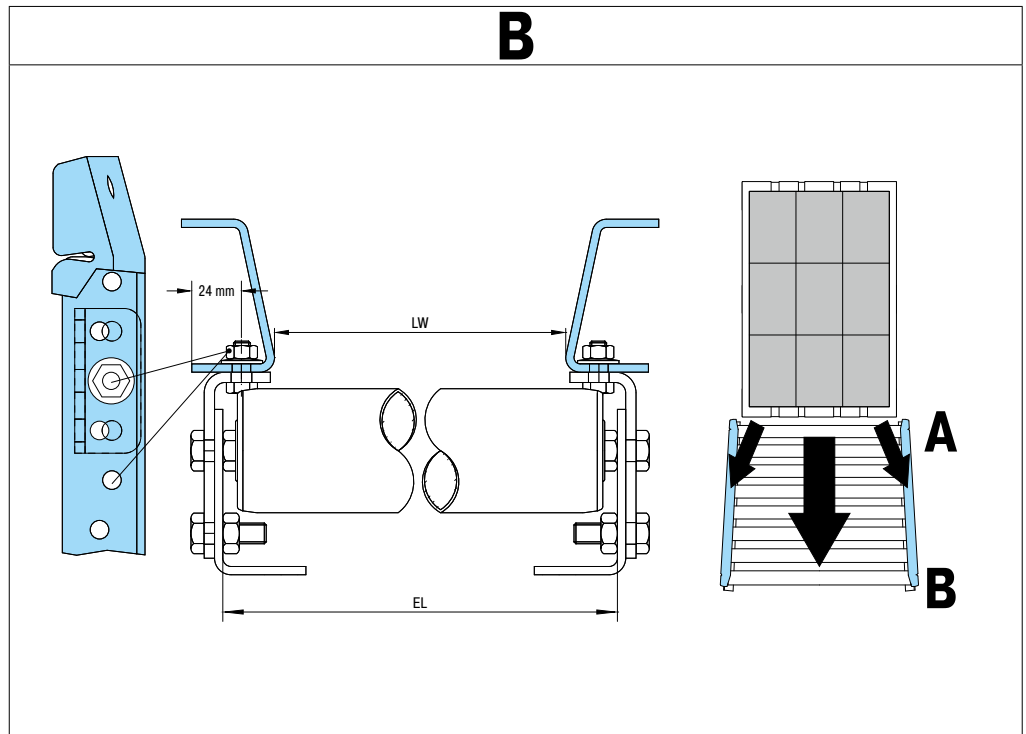
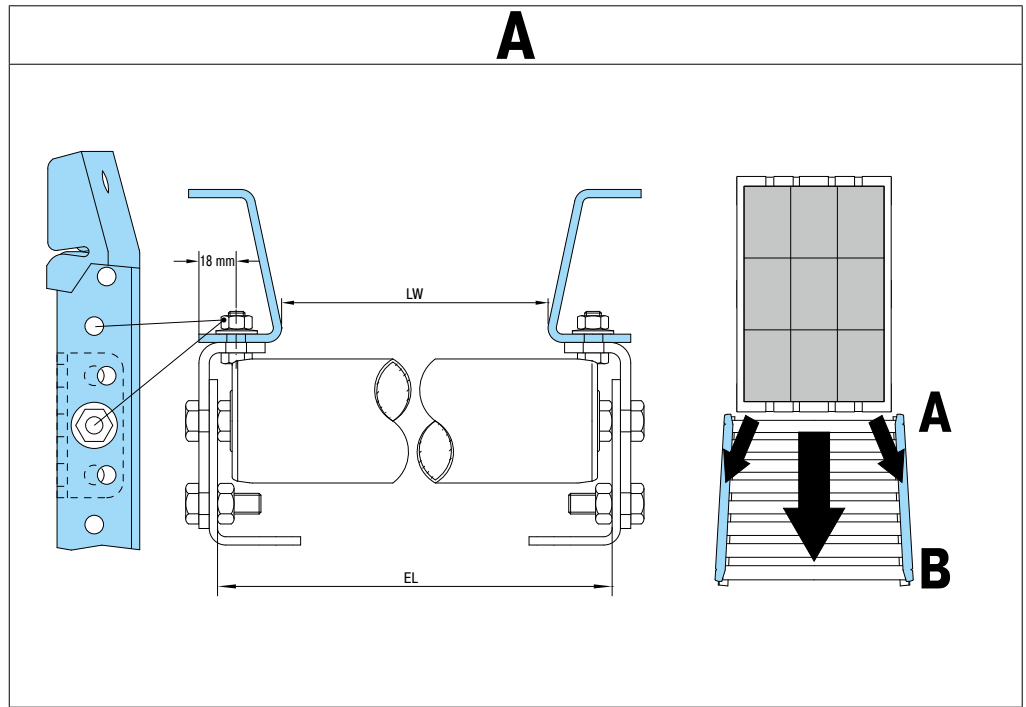

A		B	
EL	LW	EL	LW
872 mm	810 mm	872 mm	822 mm
1072 mm	1010 mm	1072 mm	1022 mm
1272 mm	1210 mm	1272 mm	1222 mm

Table 10 : Mounting dimensions of in-feed guide

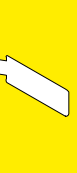

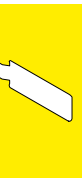

			
①		Conveyor roller \varnothing 60 mm	1x
②		M10 x 30 mm DIN EN ISO 4017	2x
③		M10 DIN EN ISO 4032	2x

Table 11 : List of conveyor roller parts \varnothing 60 mm.



1. Unfasten the bolts (2) at both ends of the roller (1).
2. Fully unfasten both bolts (2) and remove them.
3. Remove the defective roller.
4. Place the new roller in the same place (Please check: The number of unoccupied drill holes between the rollers must be the same).
5. Position the nut (3) and fasten the bolt (2).
6. Repeat step 5 on the other side.

16.4 Replace brake roller

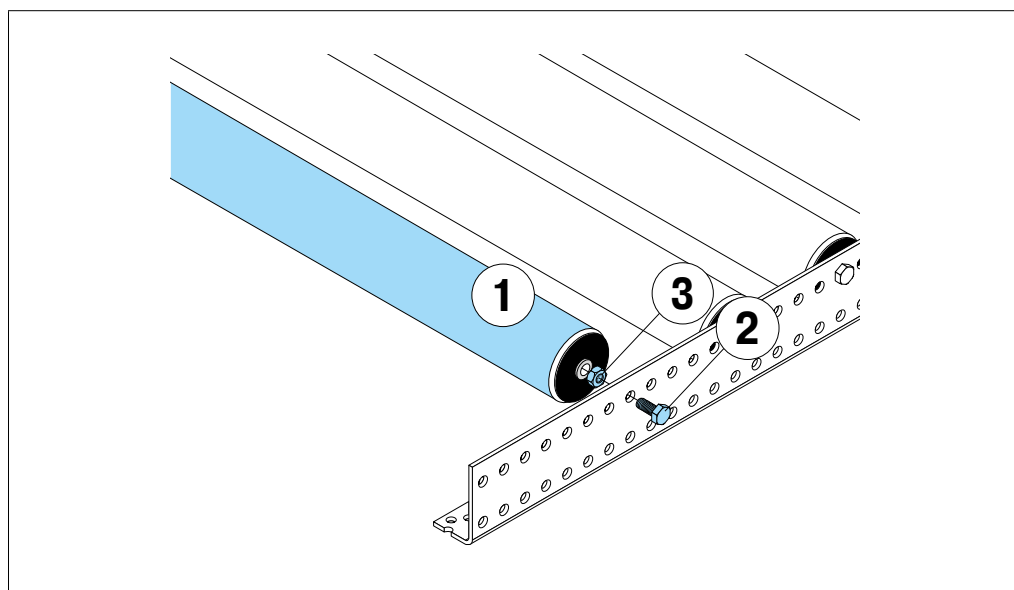
①		Brake roller ø 80 mm	1x	
②		Mounting plate	1x	
③		Mounting plate with bolt	1x	
④		M10 x 20 mm DIN EN ISO 4017	4x	
⑤		M10 DIN EN ISO 4032	4x	

1. Demount the defective roller.
2. Position the brake roller (1) on the bolt of the mounting plate (3) and place the mounting plate (2) on the brake roller axle.
3. Note the direction of rotation.

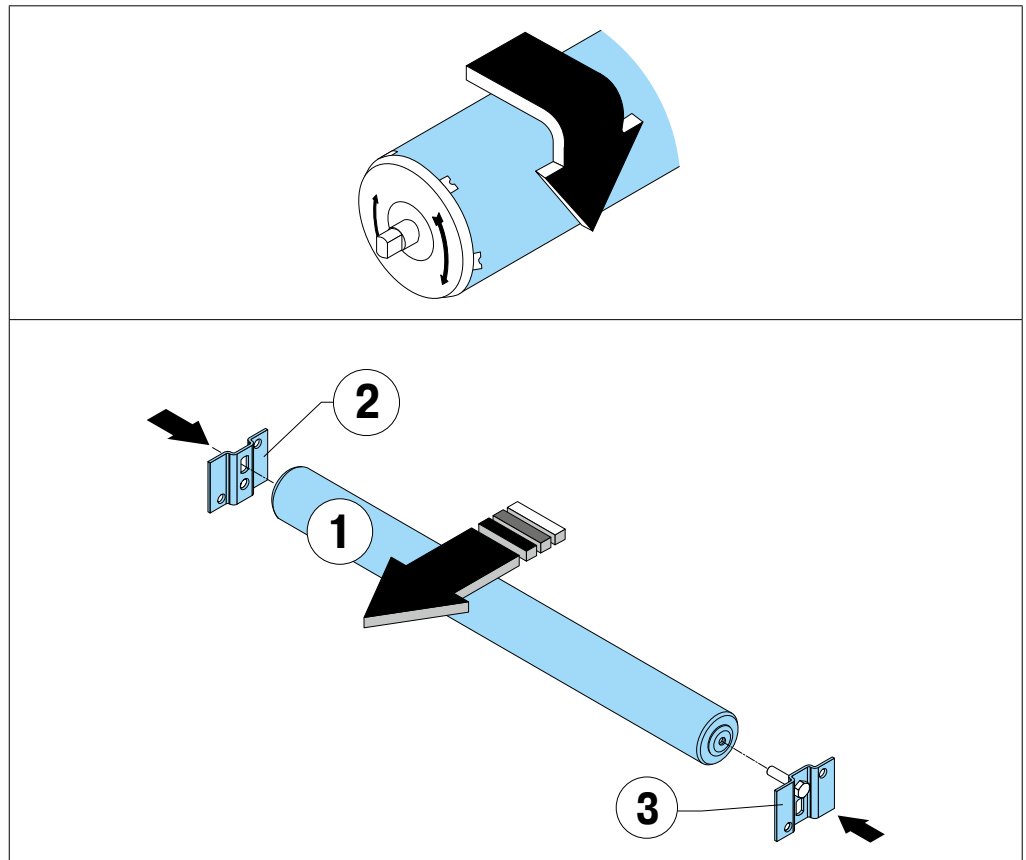

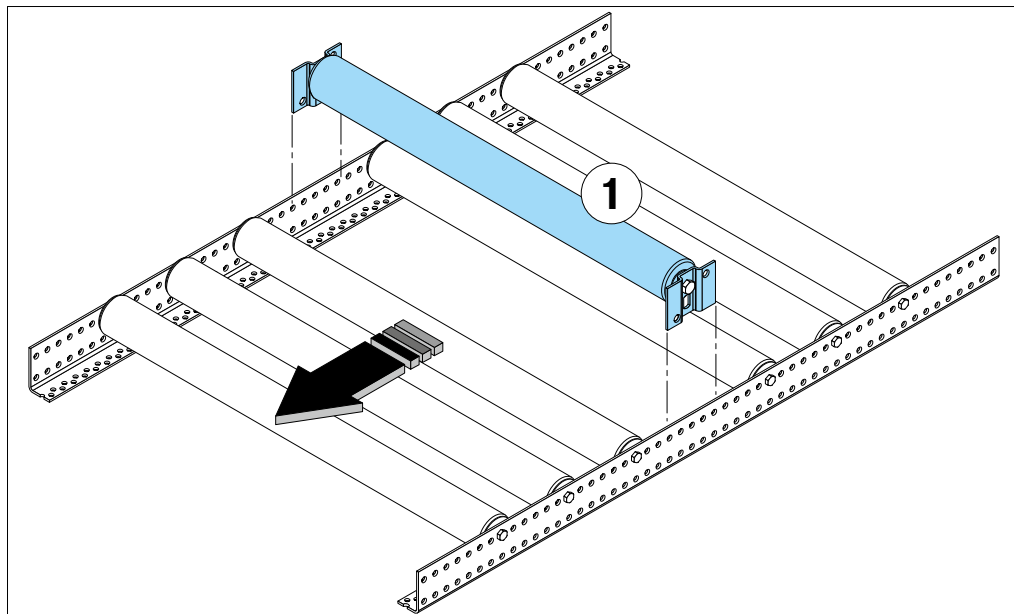
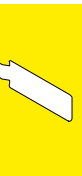

4. Place the assembly centrally between adjacent rollers.

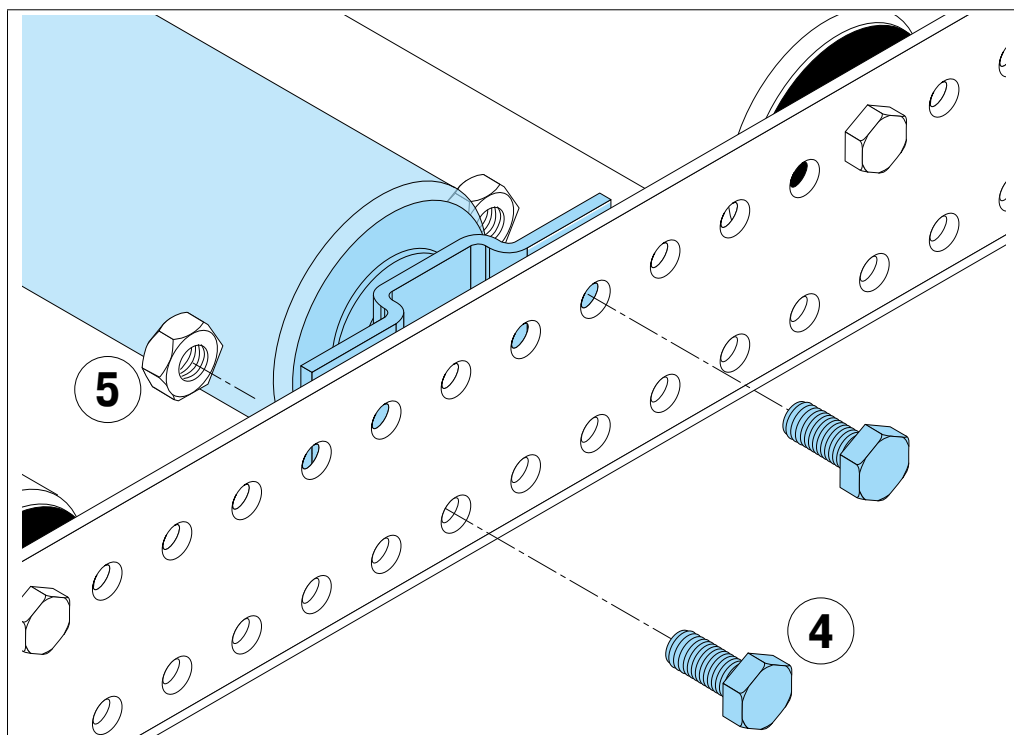

5. Fix the mounting plates to the roller lane side sections with screws (4) and nuts (5).

6. Tighten the bolts with a torque of 40 Nm.

16.5 Replace roller conveyor guard

①		Stopper plate	1x
②		Bracket of roller conveyor guard	1x
③		M10 x 30 mm DIN EN ISO 4017	7x
④		ø 10.3 mm	7x
⑤		M10 DIN EN ISO 4032	7x

The roller conveyor lane is protected against damage by lift truck forks on both the retrieval side (A) and the replenishment side (B).

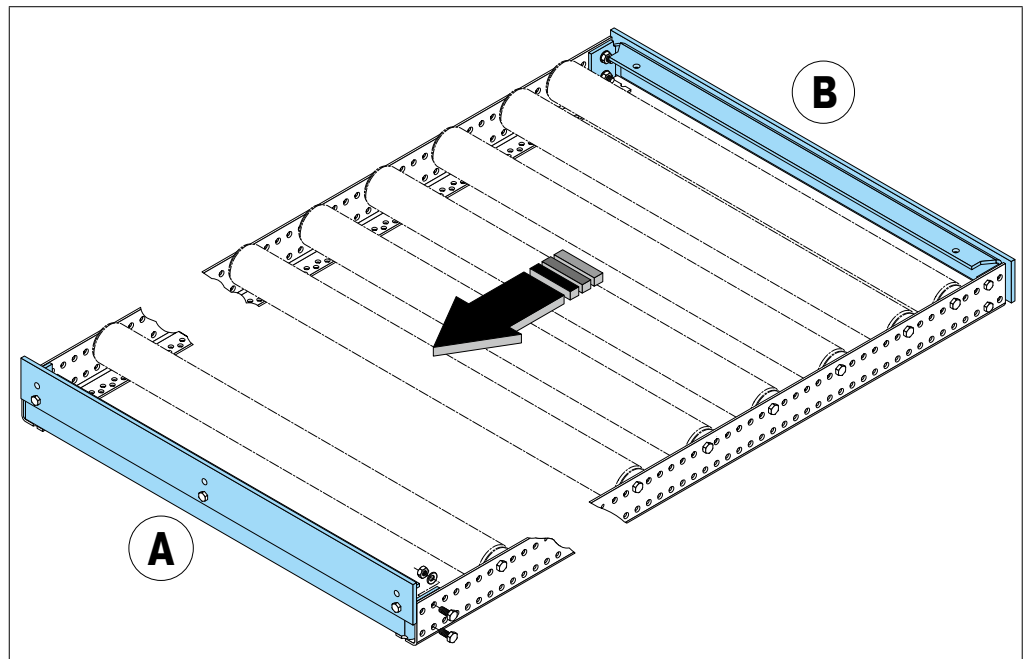

6. Tighten the bolts with a torque of 40 Nm.



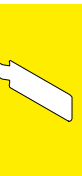

16.6 Replace roller conveyor guard

1. Demount the damaged roller conveyor guard.
2. Connect the stopper plate (1) to the bracket of the roller conveyor guard (2).
3. If the roller conveyor guard is to be mounted on the retrieval side, fasten the stopper plate to the roller conveyor bracket through hole (A) with the bolts (3), lock washers (4) and nuts (5).
4. If the roller conveyor guard is to be mounted on the replenishment side, fasten the stopper plate to the roller conveyor bracket through hole (B) with the bolts (3), lock washers (4) and nuts (5).

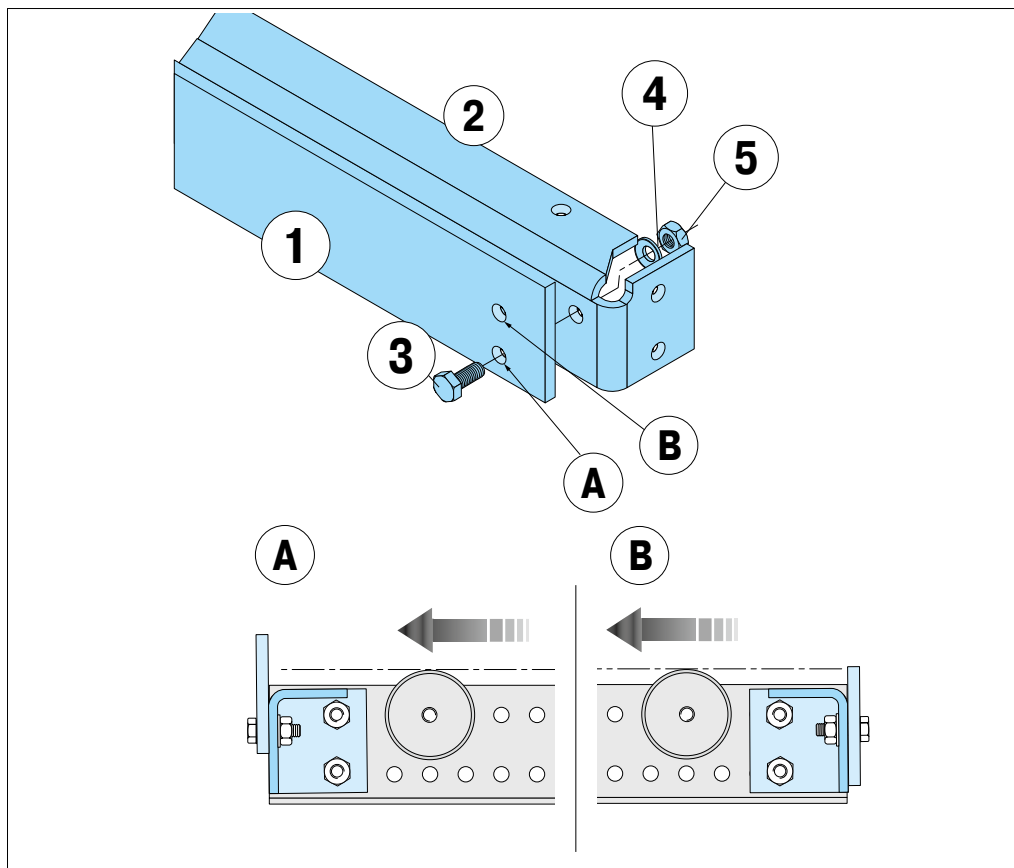

5. On the retrieval side, the projecting stopper plate serves as a pallet stopper.
6. Tighten the bolts with a torque of 40 Nm.

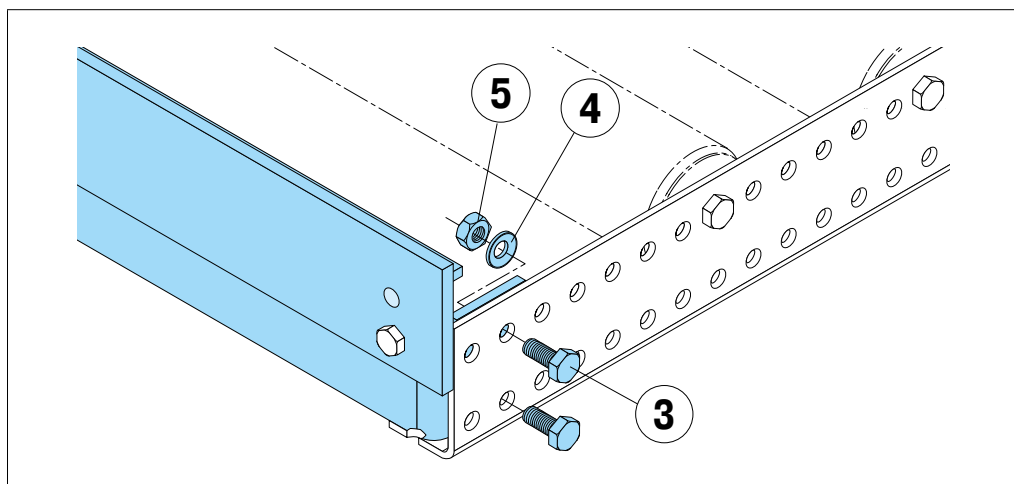

7. Fasten the roller conveyor guard to the roller lane side sections using the bolts (3), lock washers (4) and nuts (5).

16.7 Replace load separator flag

FlowStop load separators are only available in one version, but can be mounted on the left or the right side of a roller conveyor lane.

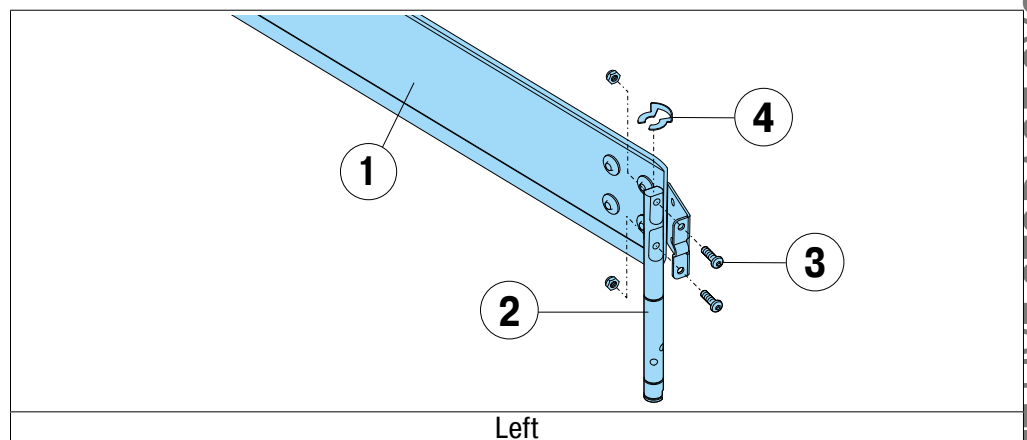
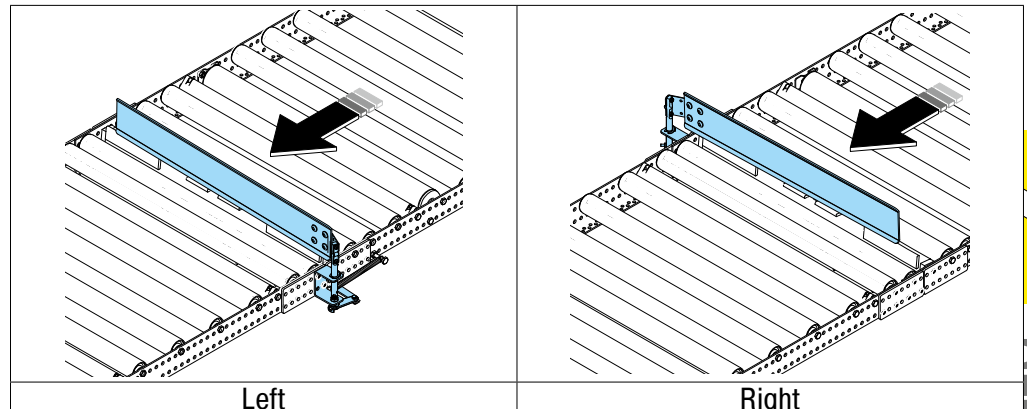

1. Separate the flag (1) from the control lever (2) by unfastening the two screws (3) and removing the safety catch (4) on the control lever (2).

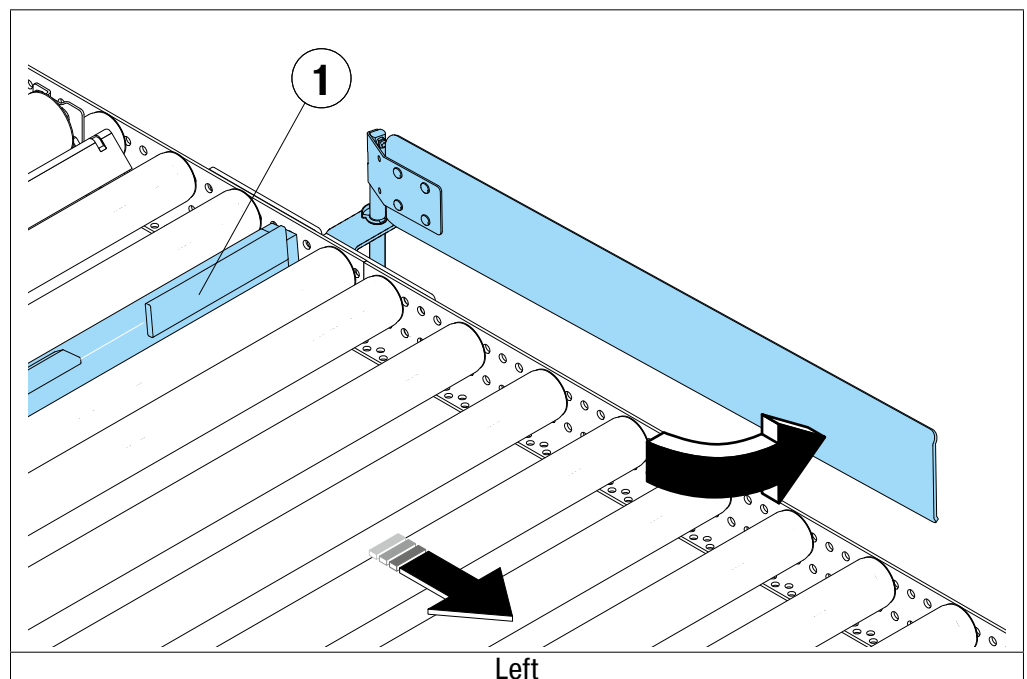

2. Mount the new flag in the same position and orientation.
3. Check whether the swing-forward function is triggered correctly by manually operating the stopper (1).

17 Spare parts

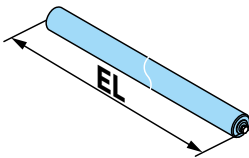
Brake roller			
Item no.	Name	EL/mm	
29498	124/ 109.8 sv	124	
29500	872/ 827.4 sv	872	
29501	1072/1027.4 sv	1072	
29502	1272/1227.4 sv	1272	

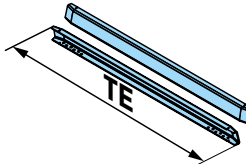
In-feed guide				
Item no.	Name	TE/mm	Suited for	
10259	769-RB /2 1003	769	Pallets	
40650	1177-Gitterboxen 1003	1177	Wire-mesh box pallets	
19577	1177-RB 1003	1177	Pallets	

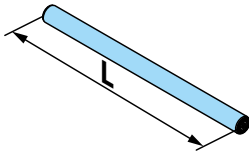
Conveyor rollers for load carriers from wood and plastic				
Item no.	Name	L/mm	Built-in length	
29494	60 x 1.5 x 109.5 svz	109.5	124	
29495	60 x 1.5 x 857.5 svz	857.5	872	
29496	60 x 1.5x1057.5 svz	1057.5	1072	
29497	60 x 1.5 x 1257.5 svz	1257.5	1272	

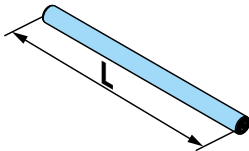
Conveyor rollers for steel bins				
Item no.	Name	L/mm	Built-in length	
C0390-0003	60 x 2.0 x 112.0 svz	112	124	
C0390-0002	60 x 2.0 x 860.0 svz	860	872	
C0390-0001	60 x 2.0 x 1060.0 svz	1060	1072	

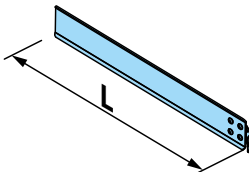
FlowStop Load separator				
Item no.	Name	L/mm	Built-in length	
46360	FlowStop Load separator flag 2.0 riveted 300 grey	300	1072	
46362	FlowStop Load separator flag 2.0 riveted 800 grey	800	872/1072/1272	

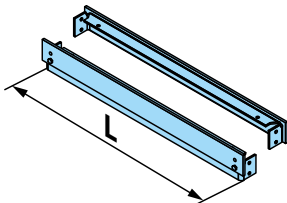
Front/rear roller lane protector				
Item no.	Name	L/mm	Built-in length	
29268	S124 R1003	125	124	
29265	S 872 R1003	873	872	
29266	S1072 R1003	1073	1072	
29267	S1272 R1003	1273	1272	

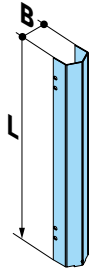
Safety components					
Item no.	Name	Upright type	L/mm	B/mm	
C0693-0014	Upright protector P12 715 R1003	P12	89.9	128.5	
C0693-0012	Upright protector P2 715 R1003	P2	68.9	98.5	
C0693-0010	Upright protector P3 715 R1003	P3	64.5	108.5	
C0693-0008	Upright protector P4-6 715 R1003	P4-6	69.8	128.5	
C0693-0006	Upright protector P7 715 R1003	P7	89.8	128.5	

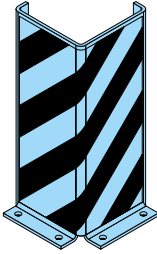
04585	Column guard AS40.2 1003	
-------	--------------------------	---

Fixing kits		
19419	Fixing kit M 8 x 30 mm galvanised	
19420	Fixing kit M 8 x 50 mm galvanised	

In case of repair work or disassembly, the resultant materials must be disposed of properly.

The following materials were used:

Rollers: Ferrous metals
Frame parts: Ferrous metals

Please observe the disposal regulations of the local authorities and federal states that apply to you.

For orders, please contact the BITO After Sales Service on:

aftersales@bito.com

Tel. 06753 122 9668
Fax 06753 122 5665

18 Index

- A**
- After-sales service 31
 - Anchor device 60
 - Angled beam profile 12, 13
- B**
- BGR 198 59
 - BGR 199 59
 - Body harness 63
 - Bolt-on connector 12
 - Brake roller 12, 31, 65, 69, 71, 74
- C**
- CE 0158 60
 - Channel storage 10
 - CHEP pallet 10, 46
 - Cladding 12
 - Cleaning 5, 6
 - Column guard 12, 15
 - Column guards 75
 - Conveyor roller 74
 - Conveyor rollers 65
- D**
- DEKRA 64
 - DGUV (German Accident Prevention Regulations) 6, 9, 19, 63
 - DIN EN 365 64
 - DIN EN 15635 31
 - DIN (ÖNORM/SN) EN 795:2012-10 60
- E**
- easyHook 42
 - Euro pallet 46
- F**
- Fall arrest system 61
 - Fax 64
 - FIFO principle 11
 - First-in, First-out 21
 - Floor beam 12
 - FlowStop 65, 74
 - FlowStop Load separator 12
 - Forklift truck 40
 - Front/rear roller conveyor guard 65, 71, 72, 73
 - Front/rear roller lane protector 12, 74
- G**
- Gravity-driven pallet movement 10
- H**
- Hand pallet truck retrieval unit 12, 14
 - High density storage 10
- I**
- Inclined roller lanes 10
 - Industry pallet 46
 - In-feed guide 12, 65, 74
 - Instructions for assembly and use 18
- L**
- Lane 5, 6, 47
 - Lane incline 10, 22, 24, 26
 - Last-in, First-out 24
 - LIFO principle 11
 - Lift truck 5, 6
 - Load 5, 6
 - Load alignment/centering 65
 - Load carrier 5, 8
 - Load carrier capacity 10
 - Load carriers 6, 19
 - Loading unit 12
 - Load separator 11, 65
- M**
- Maintenance 5, 6
 - Maintenance & Inspection service 31
 - Malfunctions 32, 34, 37
 - Management inventory methods 4
 - Mid-lane separator 12
- O**
- Order picking 11
- P**
- Pallet 5, 6
 - Pallet disrupting the workflow 38
 - Pallets on hold behind a load separator 12, 27
 - PLSAccess Kit 40
 - Protective clothing 9, 28
 - Protective equipment 5, 6
 - Push-back system 11
- R**
- Racking level 5, 6
 - Racking load sign 8
 - Racking system 28
 - Racking upright 63
 - Repair 5, 6, 65
 - Retrieval unit 12
 - Roller conveyor lane 12, 13, 21, 22, 24, 25, 26, 66, 71
 - Roller conveyor lanes 11
 - Roller lane side guard 12

S

Safety at work 9
Safety instructions 4, 6
Safety regulations 5, 6
Service vehicle 5
Service vehicles 6, 9, 19

T

Tel. 64
Tethers 63
Tiltable roller conveyor segment 12
Truck wheel stopper 12
Twist-lock carabiner 42
Type examination 64

U

Upright protector 12, 15

BITO Storage Systems

Finch Way
Hemdale Business Park
Nuneaton
CV11 6WH

Tel. +44 (0)2476 388 852

info.uk@bito.com
www.bitocom