

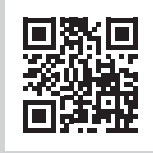

www.bito.com



shop.bito.com

- Aufbau- und Bedienanleitung (DE)
- Instructions for assembly and use (GB)
- Instructions de montage et d'utilisation (FR)
- Richtlijnen en montagehandleiding (BE)
- Instrucciones de montaje y manejo (ES)
- Istruzioni per il montaggio e l'impiego (IT)
- Montage- og betjeningsvejledning (DK)
- összeállítás és kezelési útmutató (HU)
- Instrukcja montażu i użytkowania (PL)
- Návod k montáži a obsluze (CZ)
- Návod na montáž a použitie (SK)
- Інструкція по монтажу та експлуатації (UA)
- Інструкція по сборке и использованию (RU)

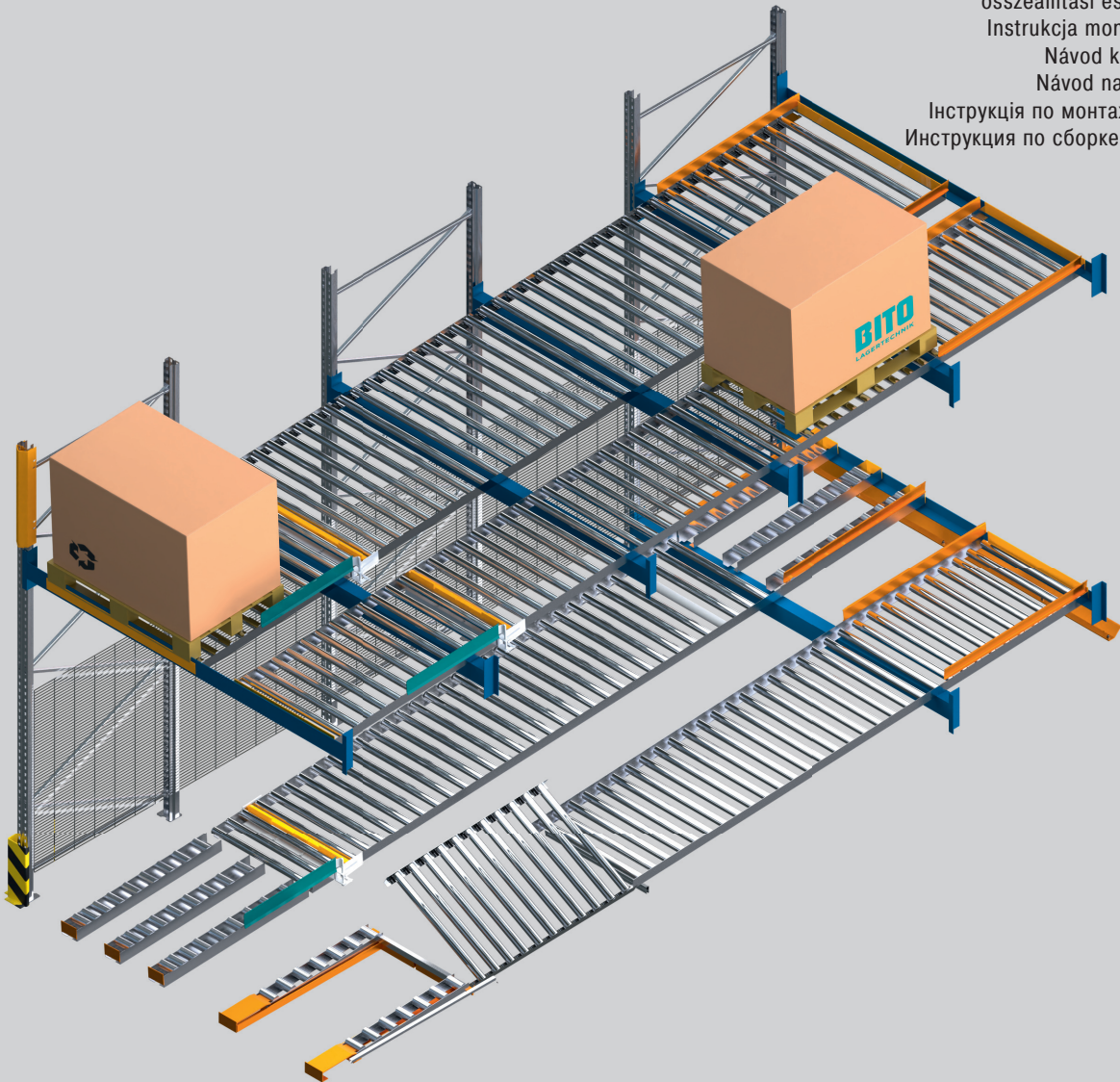

PROflow

Palettendurchlauf- und Einschubsystem

Pallet Live Storage and Push Back System

#07/2026/ART.-NR.: 39035



BITO
LAGERTECHNIK

Allgemeine Informationen General Information

4 - 12

Bitte beachten Sie die Herstellerangaben zur Dübelmontage!
Please follow manufacturer instructions for installing floor anchors!

!12

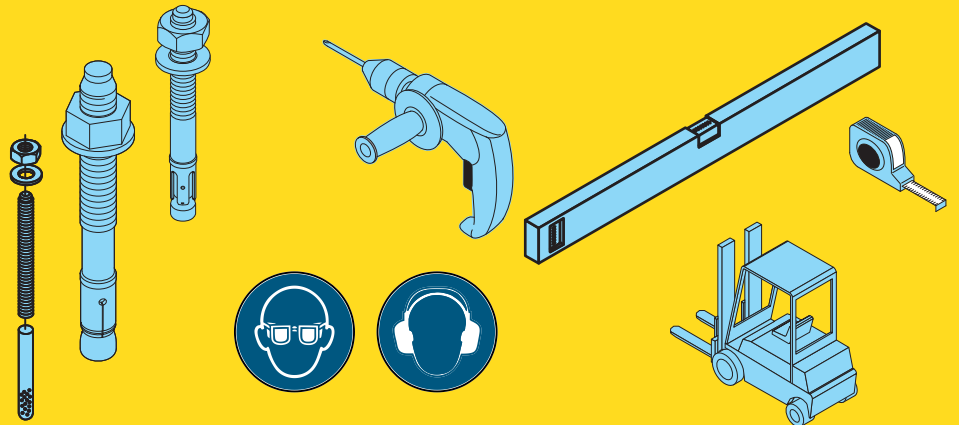
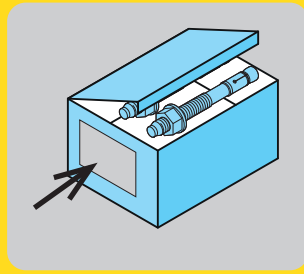

**FlowStop
8**



PROFLOW

Stützen Upright

13 - 31

P2, P3, P4, P5, P6

14

P2, P3, P4, P5, P6

16

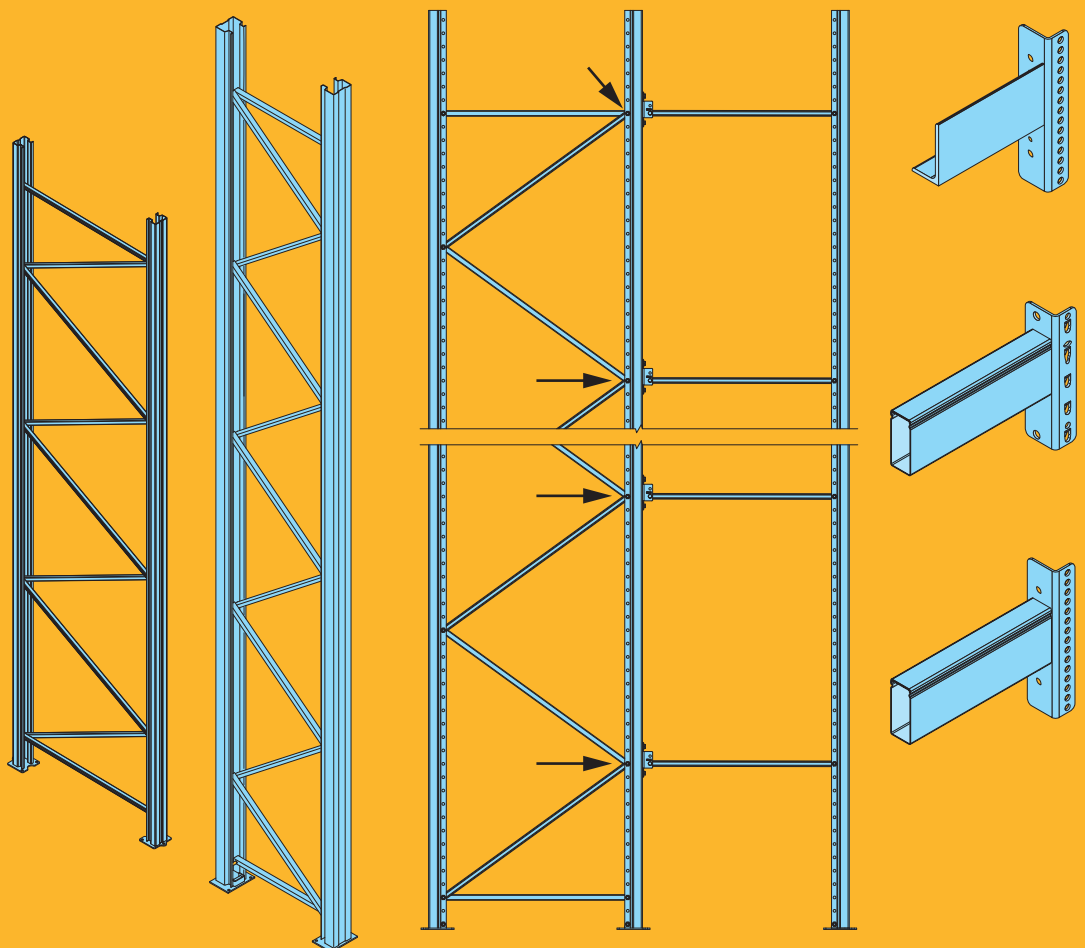

Segmente Segments

32 - 45

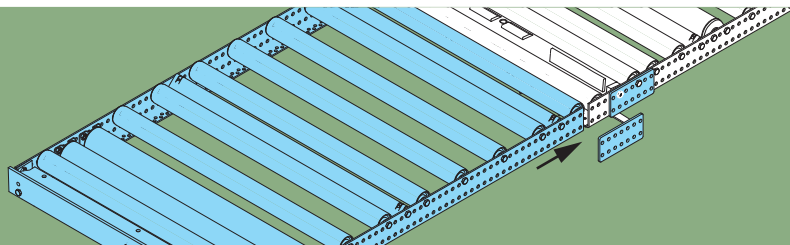

Extra

49 - 74

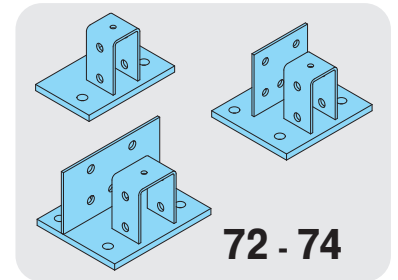
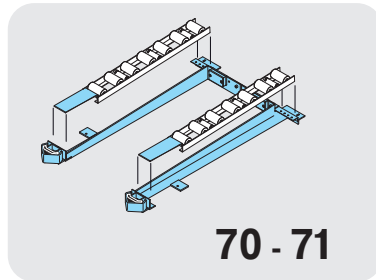
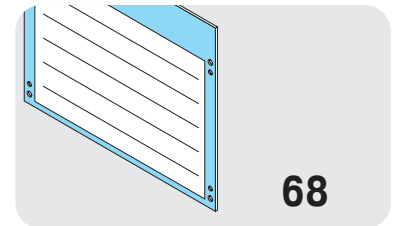
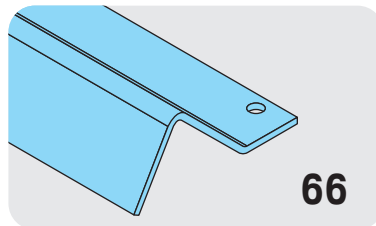
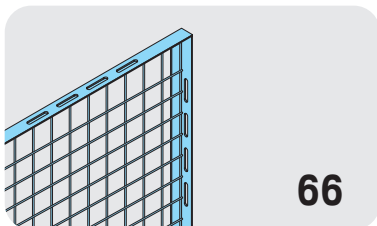
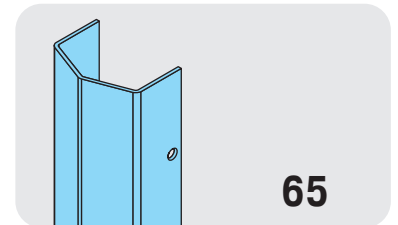
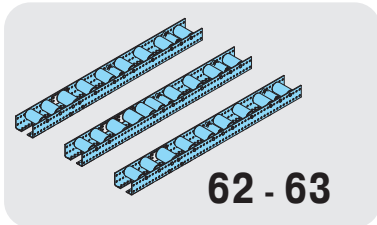
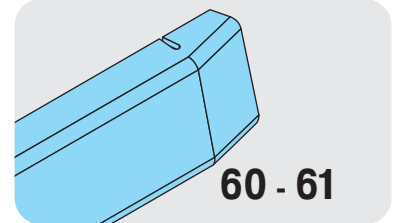
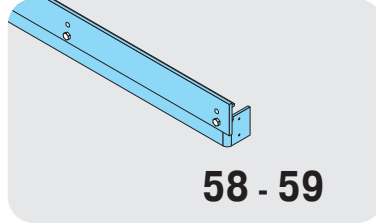
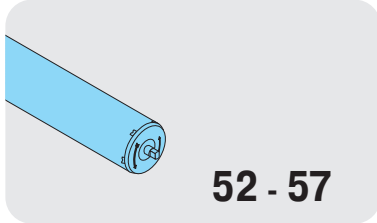
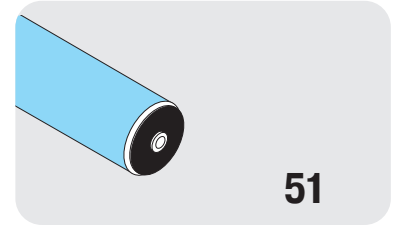
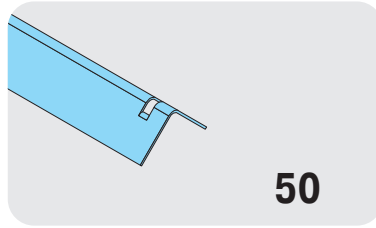

PROFLOW

Sicherheit
Safety

75 - 79

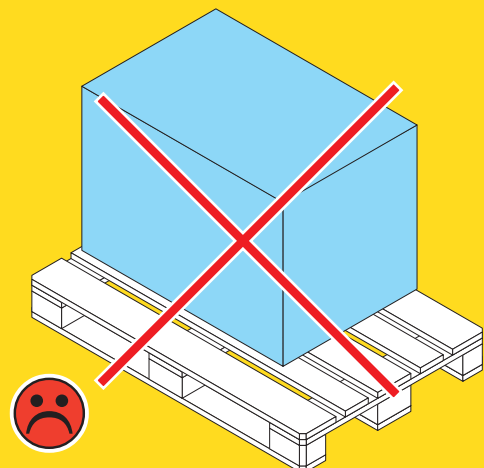
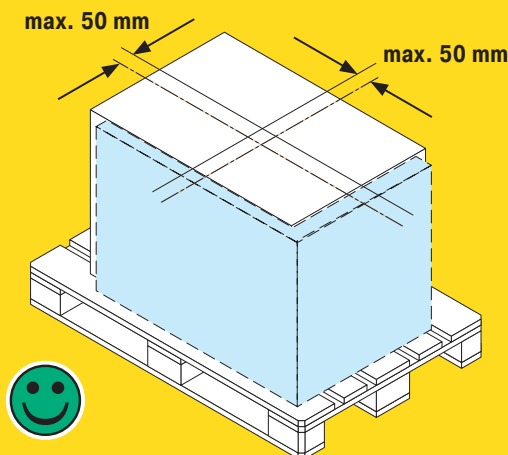



			<p># 8, 10, 11, 14 mm</p>											
	<p># 10, 13, 16, 17, 19, 22</p>													
	<p># 6, 8</p>													
	<p>125 Nm, 25 Nm</p>	<table border="1"> <tr> <td>M6-8.8</td> <td>8 Nm</td> </tr> <tr> <td>M8-8.8</td> <td>22 Nm</td> </tr> <tr> <td>M10-8.8</td> <td>45 Nm</td> </tr> <tr> <td>M10-10.9</td> <td>70 Nm</td> </tr> <tr> <td>M12-8.8</td> <td>70 Nm</td> </tr> <tr> <td>M12-10.9</td> <td>110 Nm</td> </tr> </table>	M6-8.8	8 Nm	M8-8.8	22 Nm	M10-8.8	45 Nm	M10-10.9	70 Nm	M12-8.8	70 Nm	M12-10.9	110 Nm
M6-8.8	8 Nm													
M8-8.8	22 Nm													
M10-8.8	45 Nm													
M10-10.9	70 Nm													
M12-8.8	70 Nm													
M12-10.9	110 Nm													

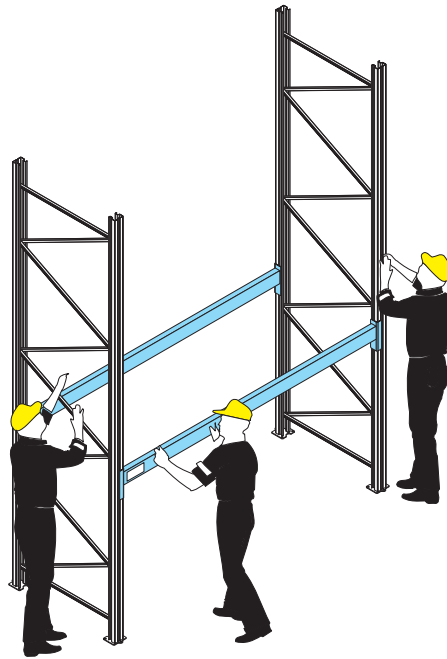

DGUV
208-061





PROFLOW

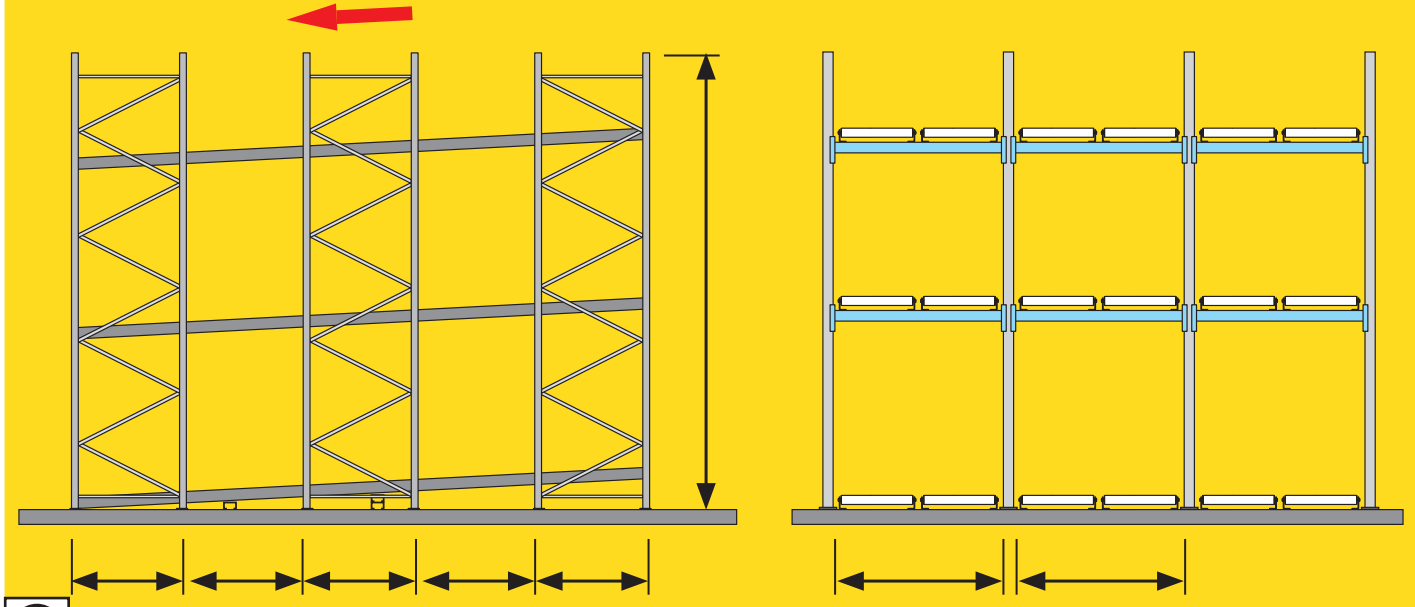
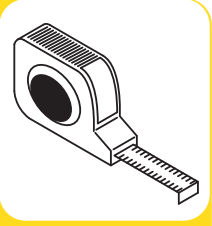

i BITO

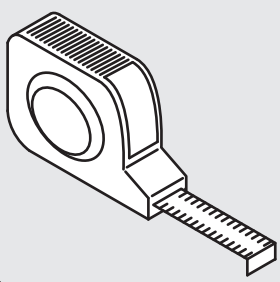
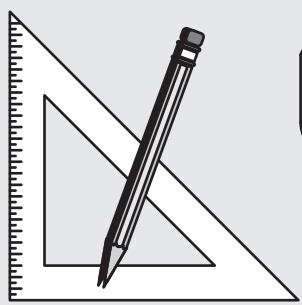
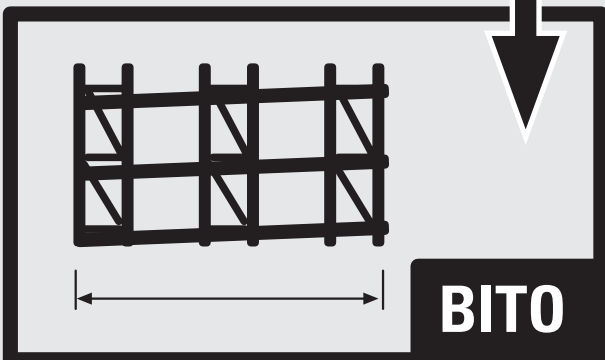

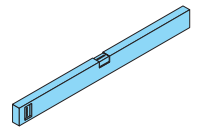
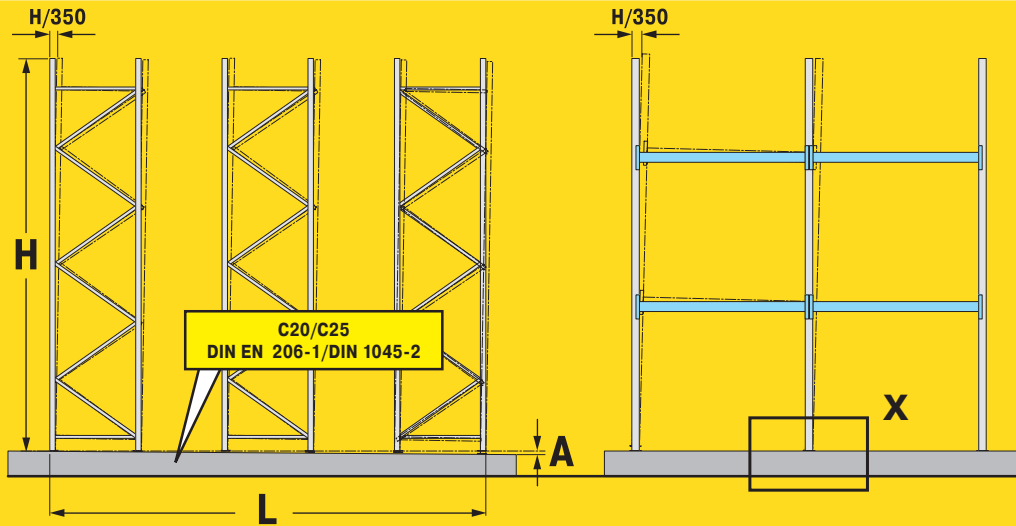

DIN EN 15620

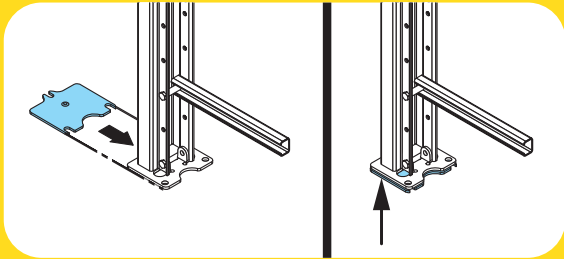
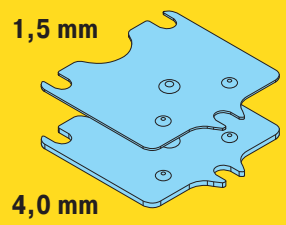

L	A
< 1 m	max. 4 mm
> 1 m - < 4 m	max. 10 mm
> 4 m - < 15 m	max. 12 mm
> 15 m	max. 15 mm

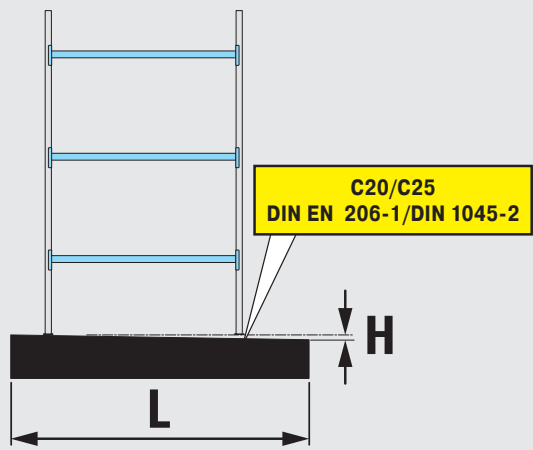
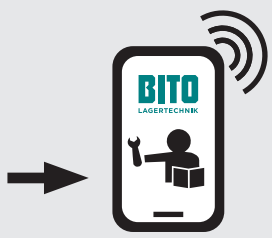
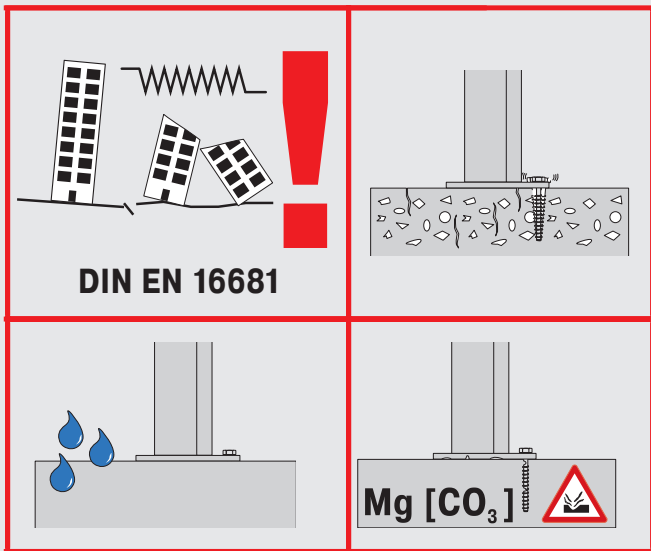

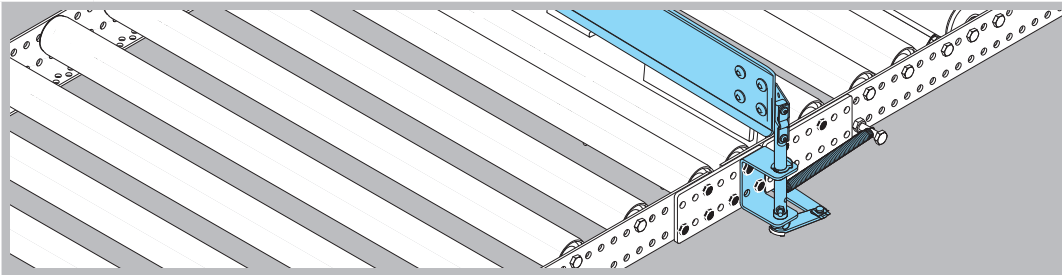

PROFLOW

FlowStop

	 Art.-Nr.	
1.	42612	EURO/Industrie/Chep Längsdurchlauf 1000 kg ≤ 1200 mm Höhe Pallet handling short side facing 1000 kg ≤ 1200 mm height
2.	42613	EURO/Industrie/Chep Längsdurchlauf 1000 kg > 1200 mm Höhe Pallet handling short side facing 1000 kg > 1200 mm height
3.	42614	EURO/Industrie/Chep Längsdurchlauf 1500 kg Pallet handling short side facing 1500 kg
4.	42615	EURO/Industrie Querdurchlauf 1250 kg ≤ 2500 mm Höhe Pallet handling long side facing 1250 kg ≤ 2500 mm height
5.	42616	Chep Querdurchlauf 1250 kg ≤ 2500 mm Höhe Pallet handling long side facing 1250 kg ≤ 2500 mm height
6.	54880	EURO/Industrie/Chep Längsdurchlauf 800 kg ≤ 1200 mm Höhe Pallet handling short side facing 800 kg ≤ 1200 mm height
7.	54881	FlowStop mit Bremstragrolle [T168] FlowStop with with brake roller [T168]
8.	54881	EURO/Industrie/Chep Längsdurchlauf 1000 kg > 1200 mm Höhe Pallet handling short side facing 1000 kg > 1200 mm height
9.	56940	CP1 Längsdurchlauf ≤ 800 kg Pallet handling short side facing ≤ 800 kg
10.	56941	CP1 Längsdurchlauf ≤ 1250 kg Pallet handling short side facing ≤ 1250 kg
11.	56942	CP3 Längsdurchlauf ≤ 800 kg Pallet handling short side facing ≤ 800 kg
12.	56943	CP3 Längsdurchlauf ≤ 1250 kg Pallet handling short side facing ≤ 1250 kg
13.	56944	Euro H1, Euro H3 Längsdurchlauf ≤ 300 kg Pallet handling short side facing ≤ 300 kg
14.	56945	Euro H1, Euro H3 Längsdurchlauf ≤ 500 kg Pallet handling short side facing ≤ 500 kg
15.	56946	Euro H1, Euro H3 Längsdurchlauf ≤ 800 kg Pallet handling short side facing ≤ 800 kg
16.	56947	Euro H1, Euro H3 Längsdurchlauf ≤ 1250 kg Pallet handling short side facing ≤ 1250 kg



R FlowStop

Rechts/Right

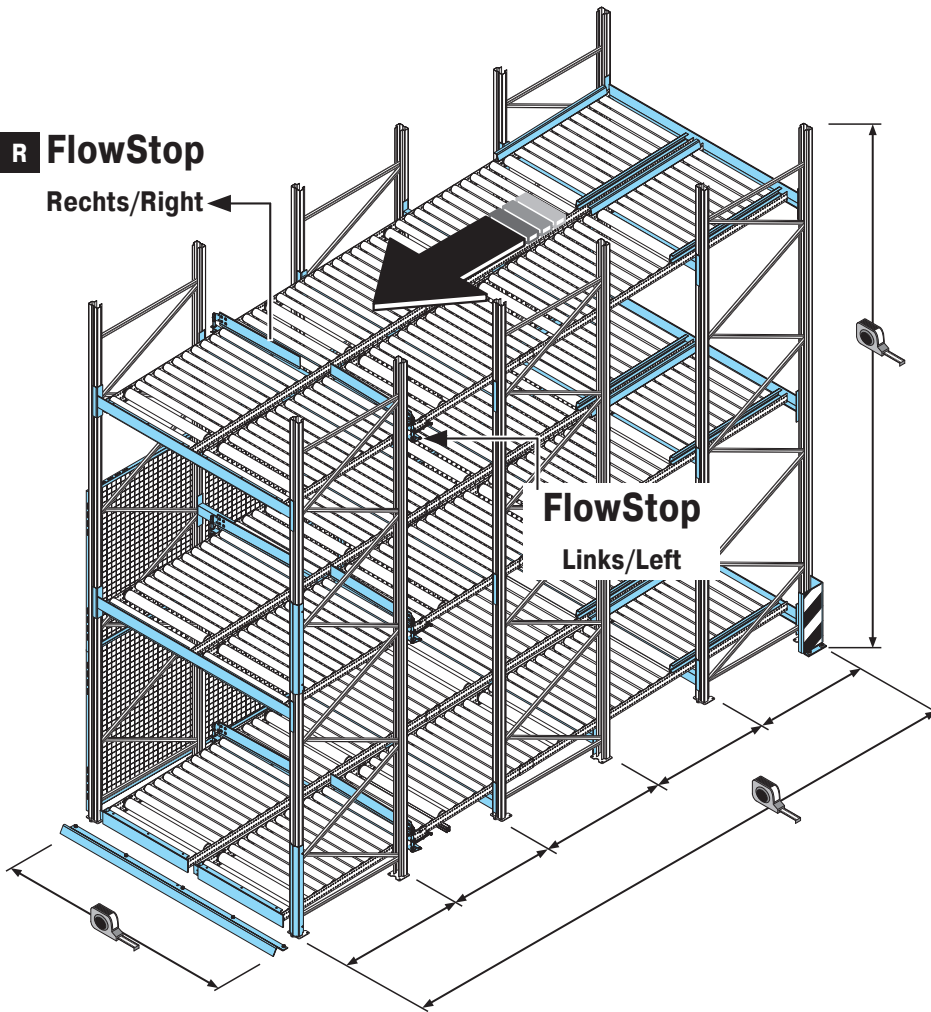

FlowStop
Links/Left

64

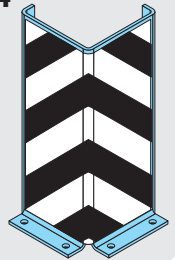

65

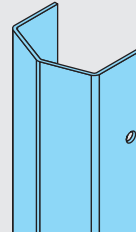

66

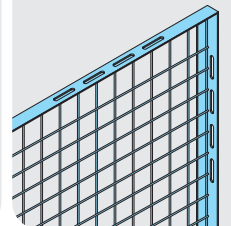

14-17

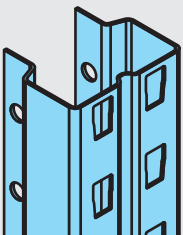

36 - 37

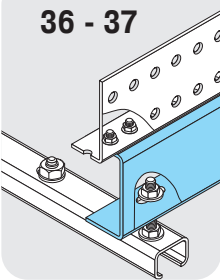

60 - 61

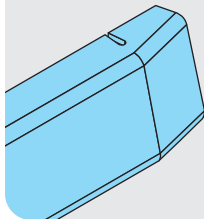

20,22-
29

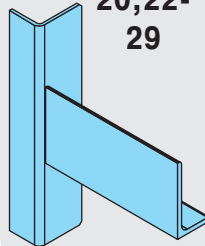

49 - 55

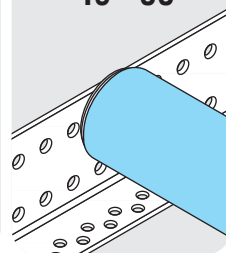

66

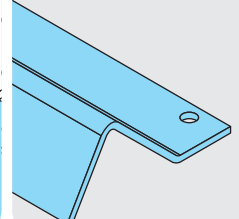

i BITO

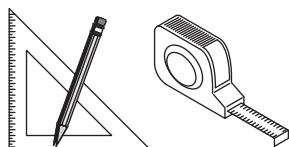
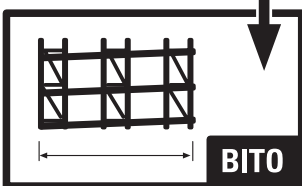

i

20xx

1	2	3	4
5	6	7	8
9	10	11	12

20xx

1	2	3	4
5	6	7	8
9	10	11	12

1x

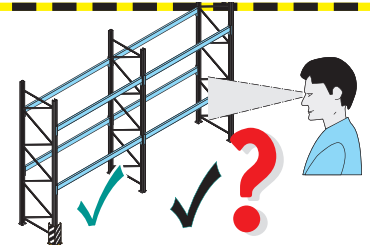

www.bitto.com



PROFLOW

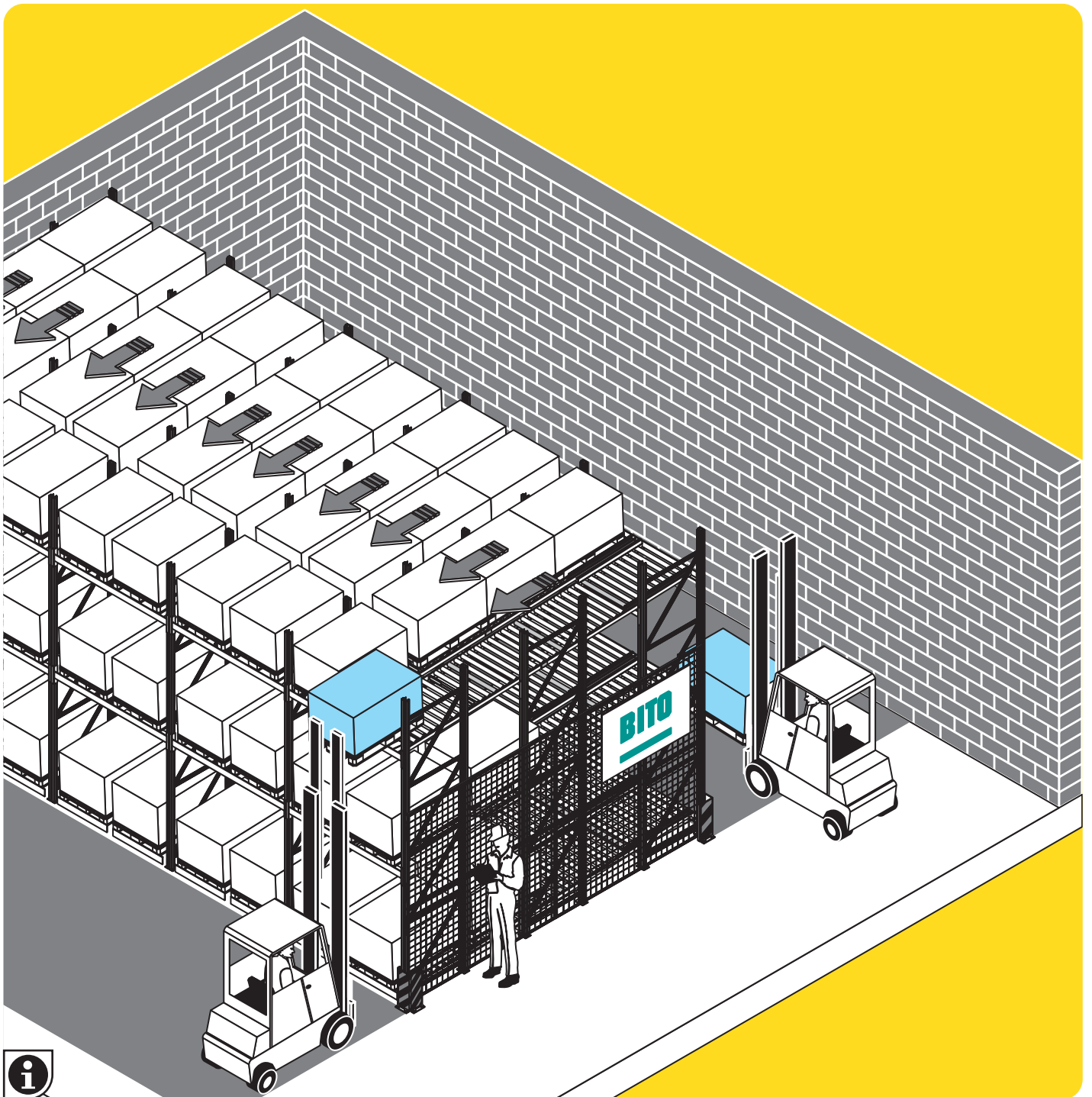



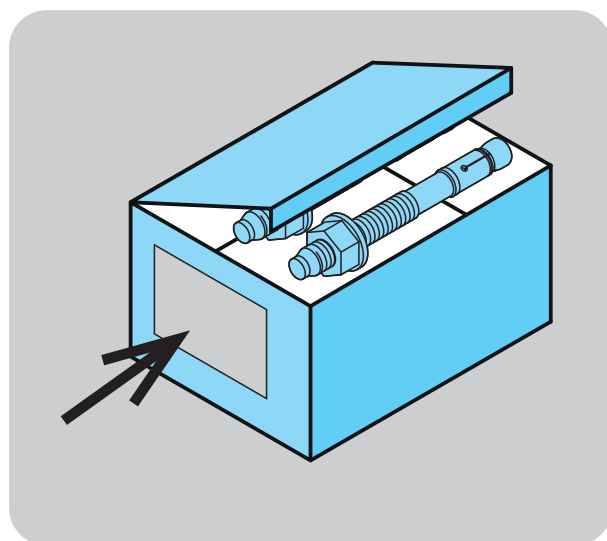

- Bitte beachten Sie die Herstellerangaben zur Dübelmontage! (DE)
- Please follow manufacturer instructions for installing floor anchors! (GB)
- Veuillez suivre les instructions du fabricant lors de l'installation de chevilles ! (FR)
- Gelieve de instructies van de fabrikant te volgen bij de installatie van vloerankers! (BE)
- Por favor, siga las instrucciones del fabricante para instalar las espigas! (ES)
- Si prega di seguire le istruzioni del produttore per il montaggio dei tasselli! (IT)
- Bemærk producentens oplysninger om montering af dyvel! (DK)
- Kérjük, kövesse a gyártó utasításait a tiplik beszereléséhez! (HU)
- Proszę stosować się do instrukcji producenta dotyczących montażu na kołkach! (PL)
- Při instalaci hmoždinek postupujte podle pokynů výrobce! (CZ)
- Při instalaci hmoždinek postupujte podle pokynů výrobce! (SK)
- Будь ласка, дотримуйтесь інструкцій виробника по установці дюбелів! (UA)
- Пожалуйста, следуйте инструкциям производителя по установке дюбелей! (RU)



P2, P3,
P4, P5, P6

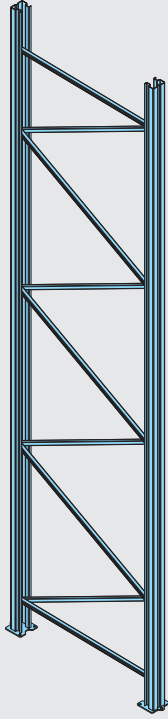

14 - 15

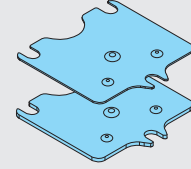

18

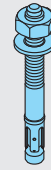

19

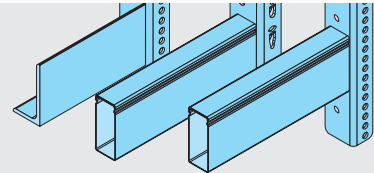

20 - 21

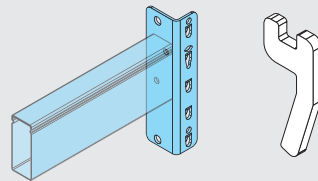

22 - 23

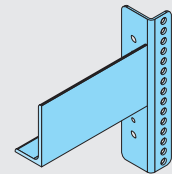

24 - 27

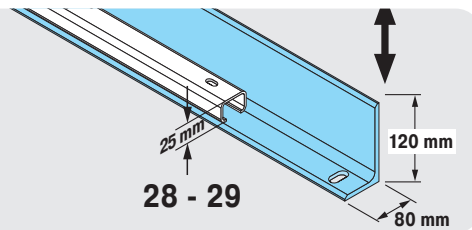

28 - 29

P7, P12

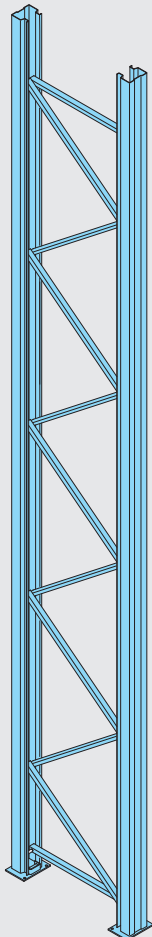

16 - 17

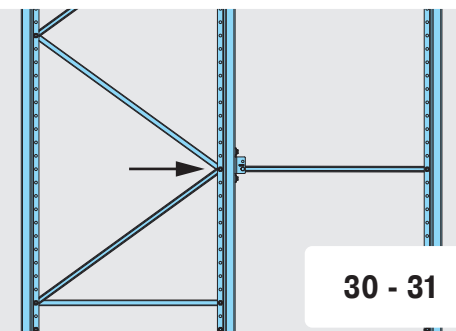

30 - 31

PROFLOW

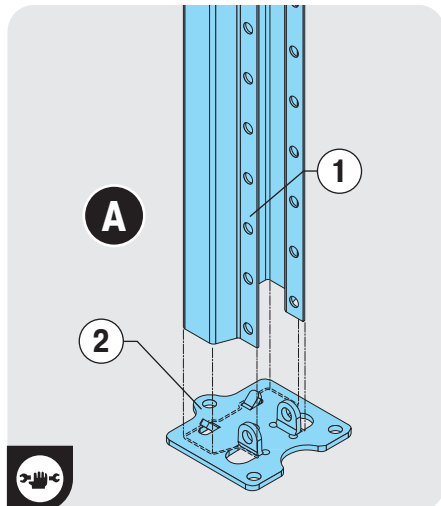
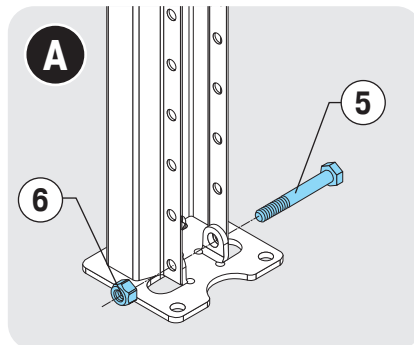
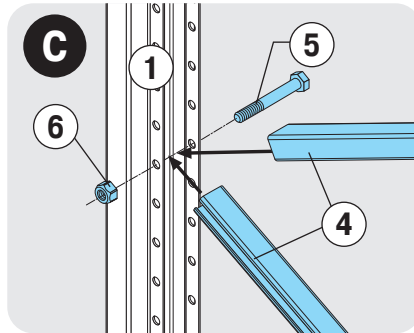
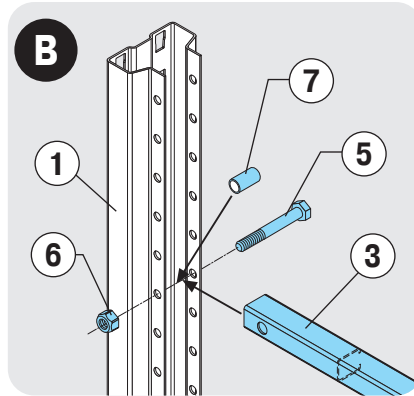
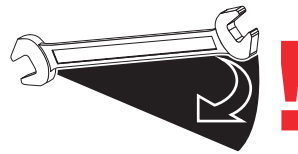
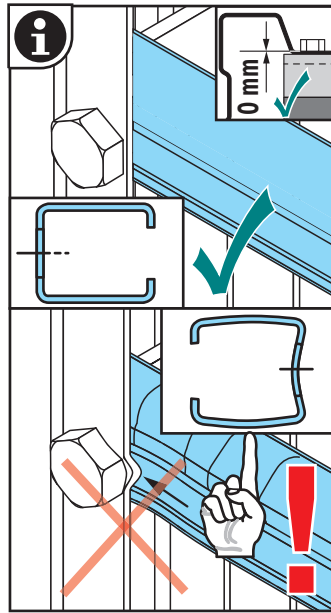
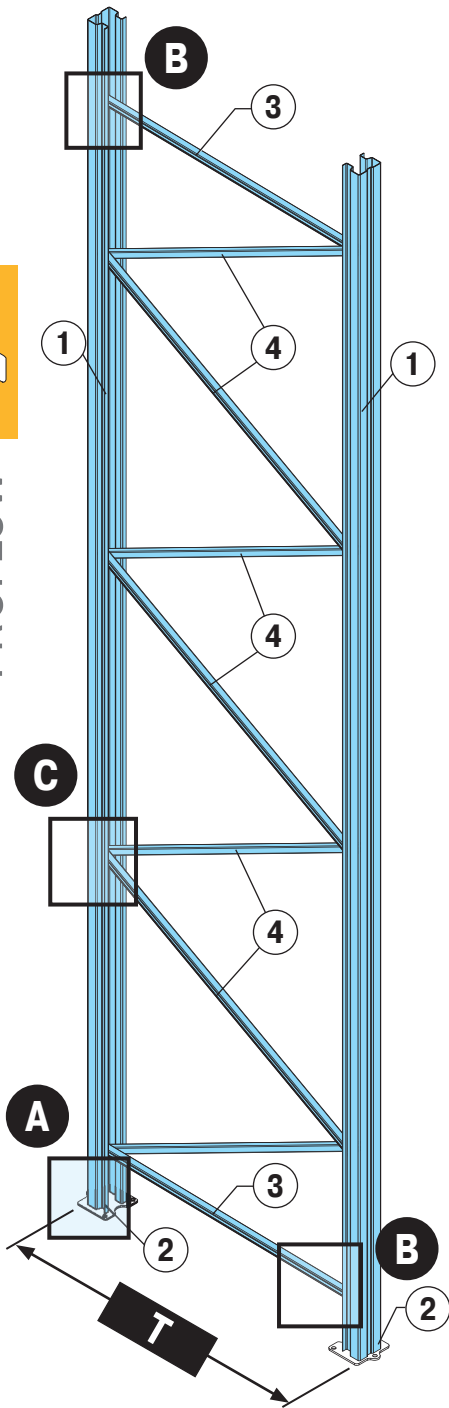

FIFO

LIFO

P2 + P3

P4 + P5 + P6

385,5 mm

114,5 mm



P2, P3, P4, P5, P6

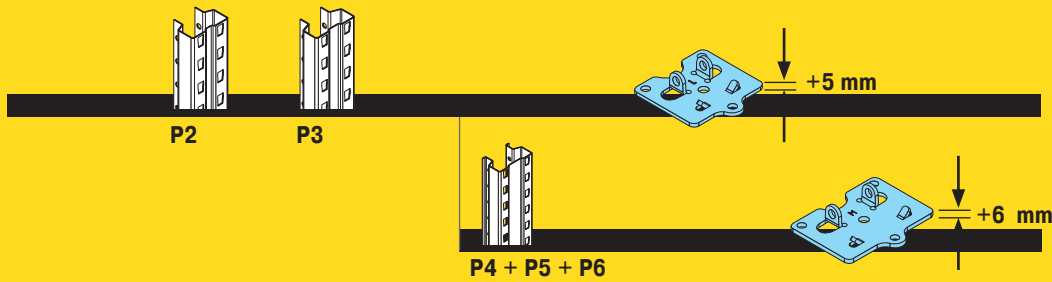
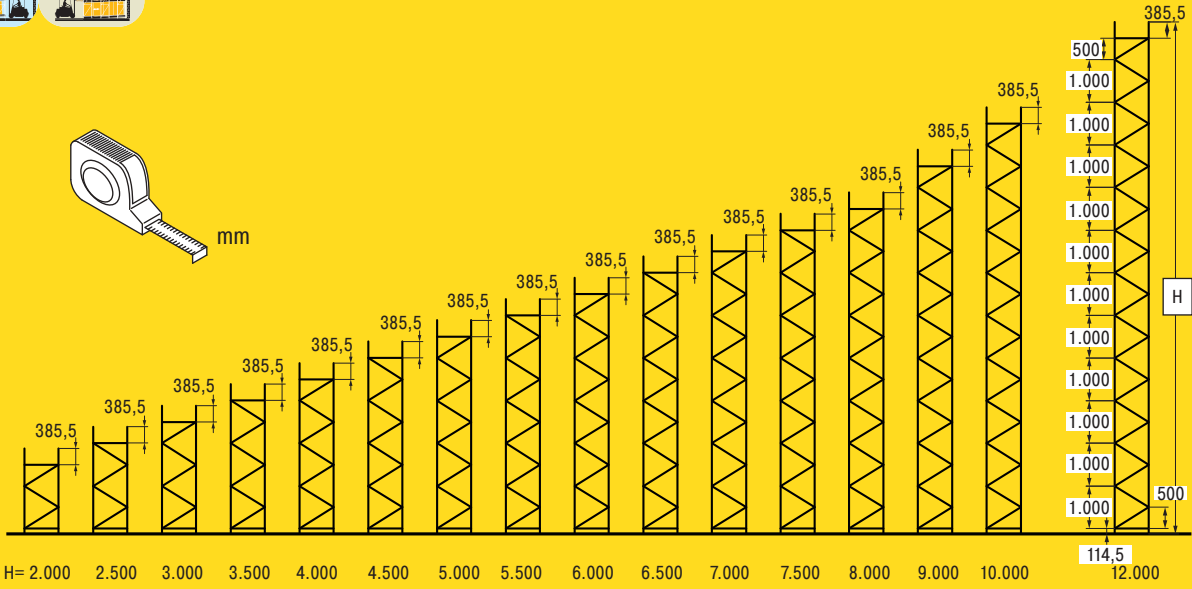

Stützrahmen Typ Frame Version	Fußplatten Typ Footplate Type	T = 1.300 mm	L		5 8.8	6 8	7 LH
			3	4			
1	LS1 2						
P2 90 mm	"L" 120 x 105 x 5 mm	25 x 21 mm	L = 1.230 mm	L = 1.331 mm	M10 x 65 m DIN EN ISO 4017	M10 DIN EN ISO 10511	ø 14 x 1,5 LH= 25 mm
P3 100 mm							
P4-P5-P6 120 mm	"M" 150 x 105 x 6 mm	35 x 25 mm	L = 1.220 mm	L = 1.322 mm	M10 x 90 mm DIN EN ISO 4017	M10 DIN EN ISO 10511	ø 14 x 1,5 LH= 34 mm

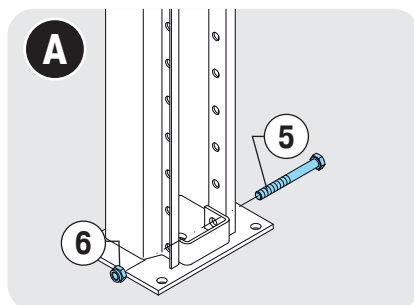
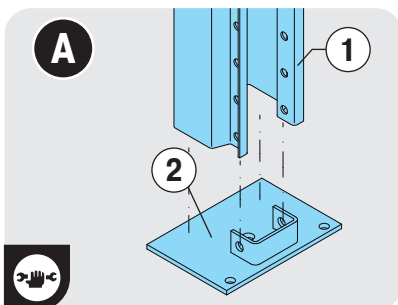
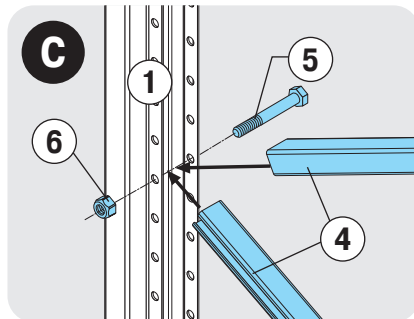
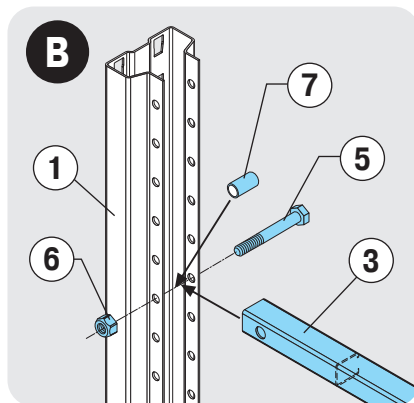
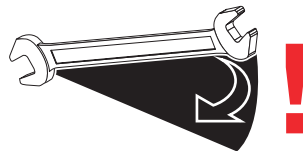
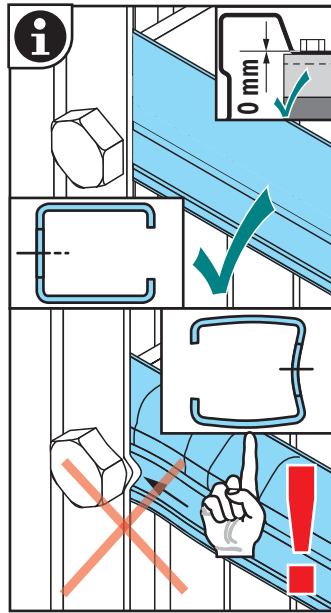
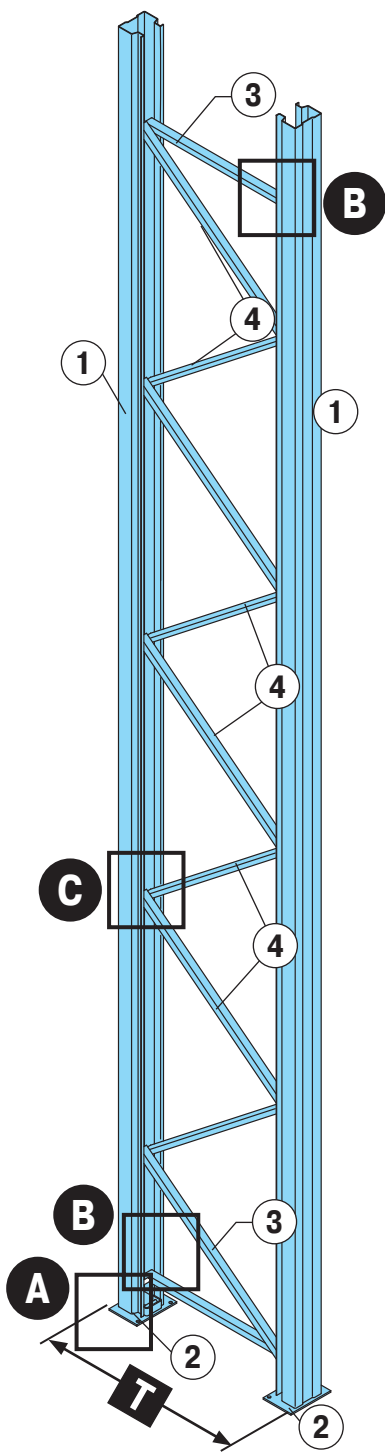

FIFO

LIFO

P7

P12

385,5 mm

385,5 mm

120,5 mm

124,5 mm

16



P7/P12

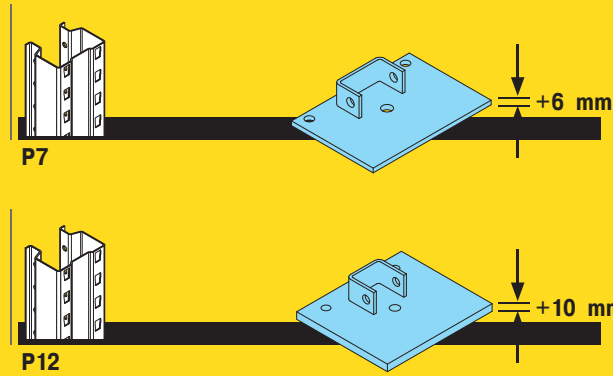
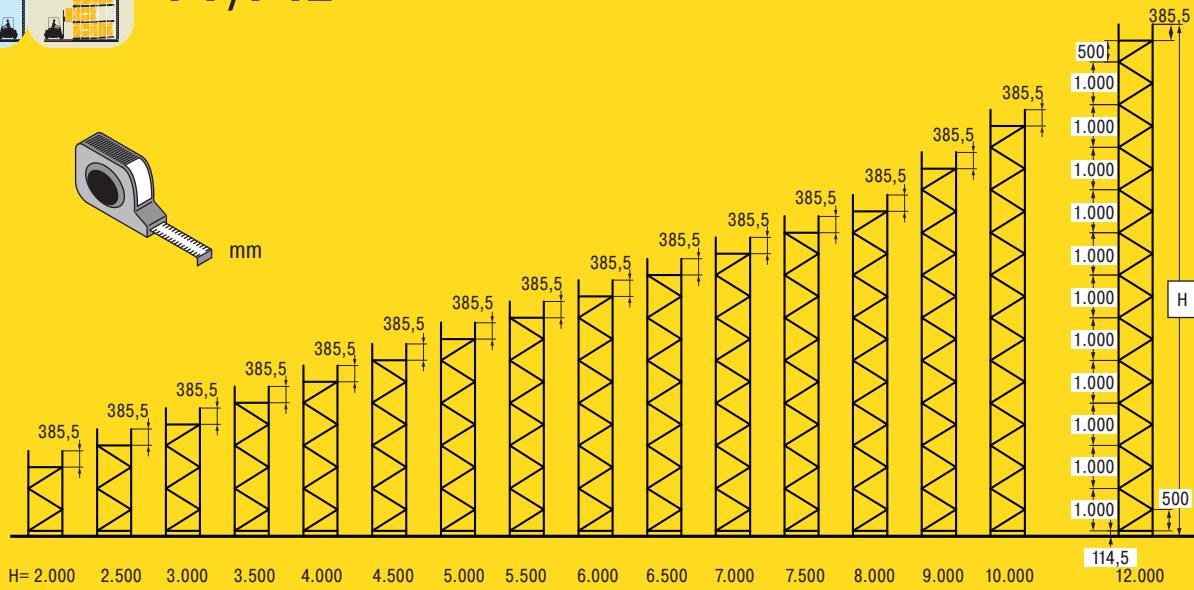

PROFLOW

Stützrahmen Typ Frame Version	Fußplatten Typ Footplate Type		T = 1.300 mm		
1	LS1		3	4	5 8.8
	2				6 8
					7 LH
			L = 1.180 mm	L = 1.285 mm	M10 x 90 mm DIN EN ISO 4017
	180 x 125 x 6 mm	35 x 25 mm			M10 DIN EN ISO 10511
					ø 14 x 1,5 LH = 34 mm
			L = 1.168 mm	L = 1.274 mm	M10 x 70 mm DIN EN ISO 4017
	160 x 160 x 10 mm	35 x 25 mm			M10 x 70 mm DIN EN ISO 10511
					ø 14 x 1,5 LH = 25 mm



PROFLOW

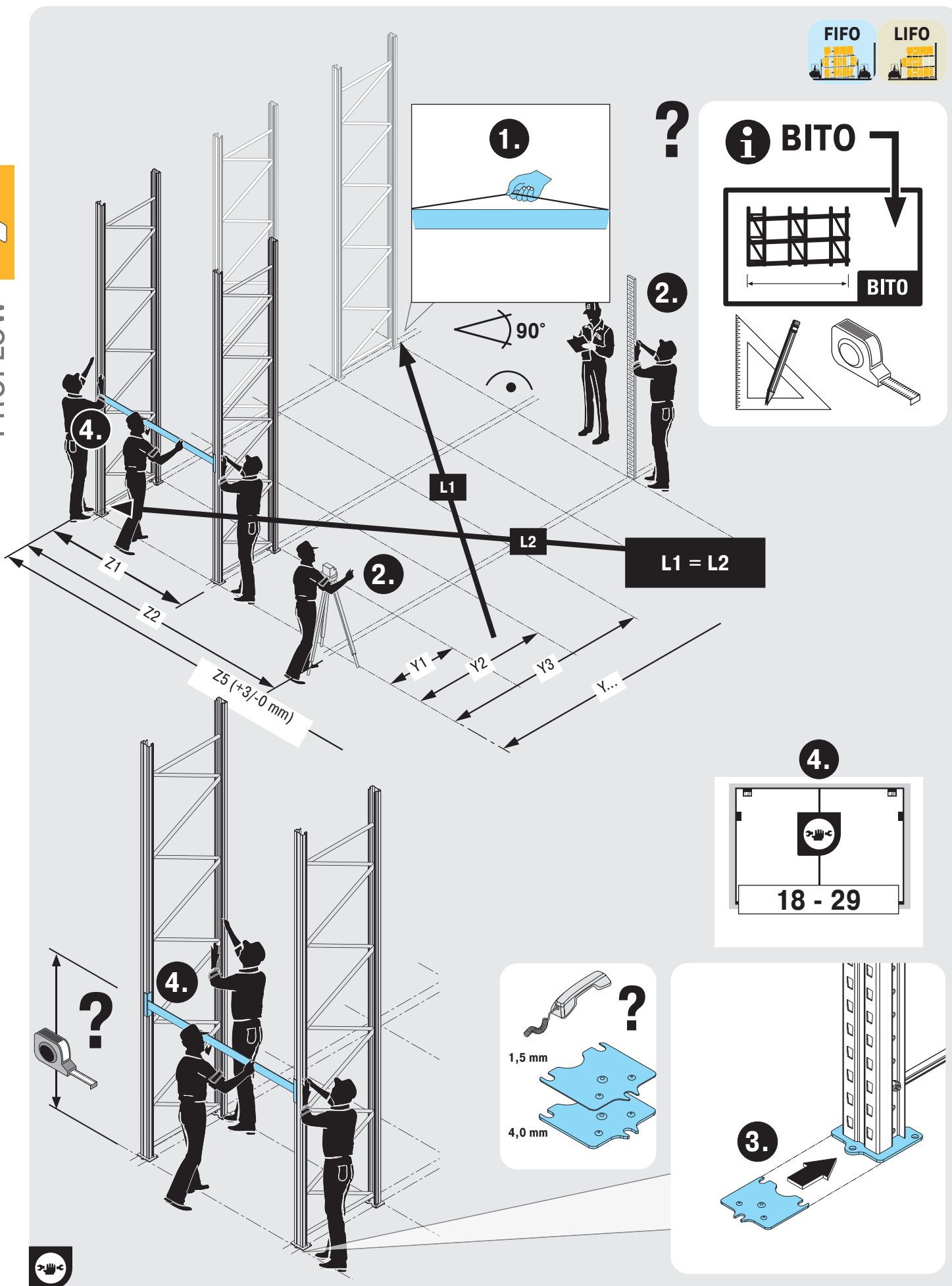

?

i BITO

4.

18 - 29

?

1,5 mm
4,0 mm

3.



Stütze Upright

BITO

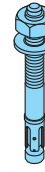

4x
M10/20
(M10/50)

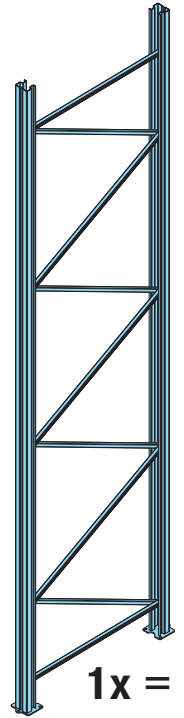

1x =

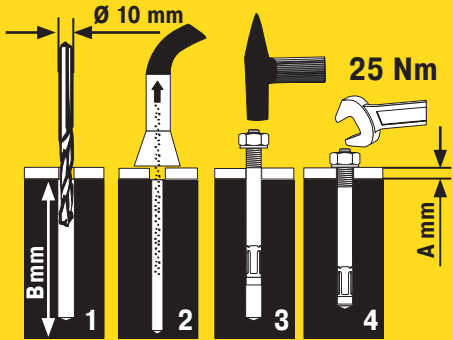

!12

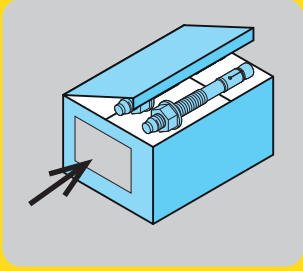

PROFLOW

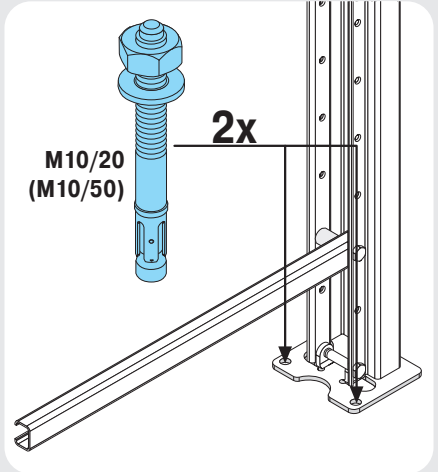
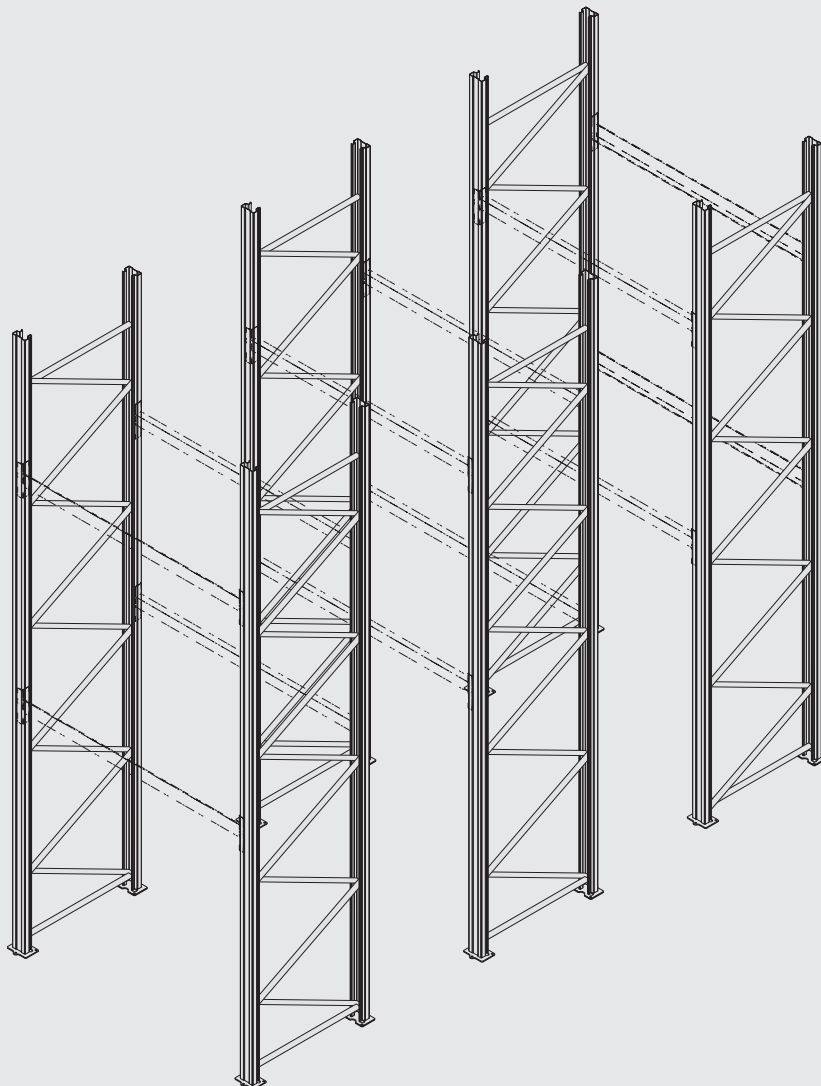

2x
M10/20
(M10/50)



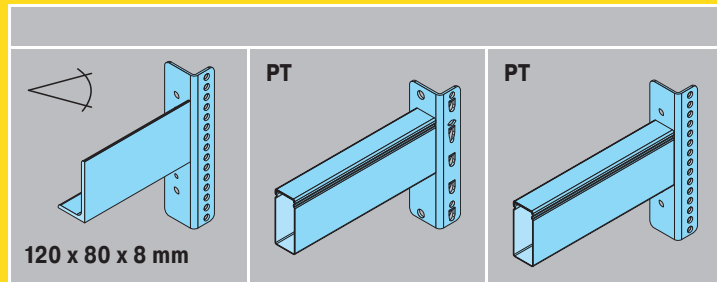

		PT	PT
T1	✓	-	-
T2	-	✓	-
T3	-	-	✓



PROFLOW

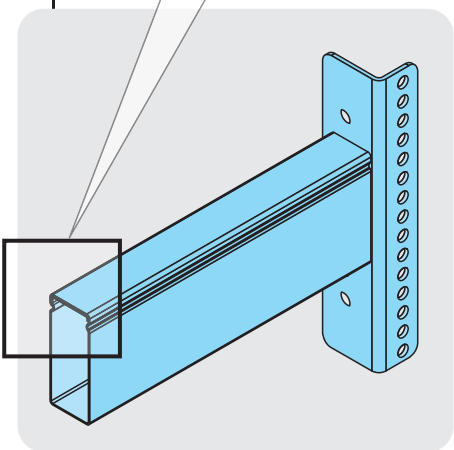
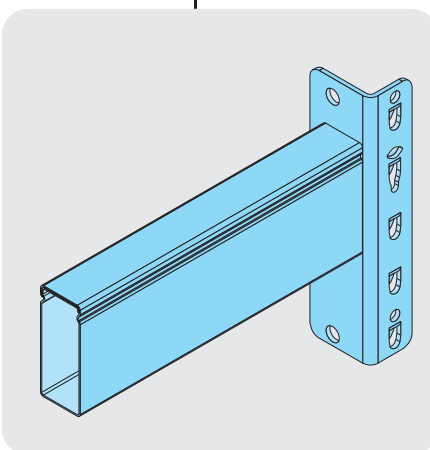
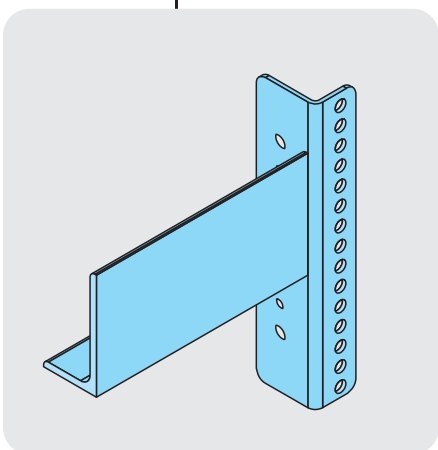

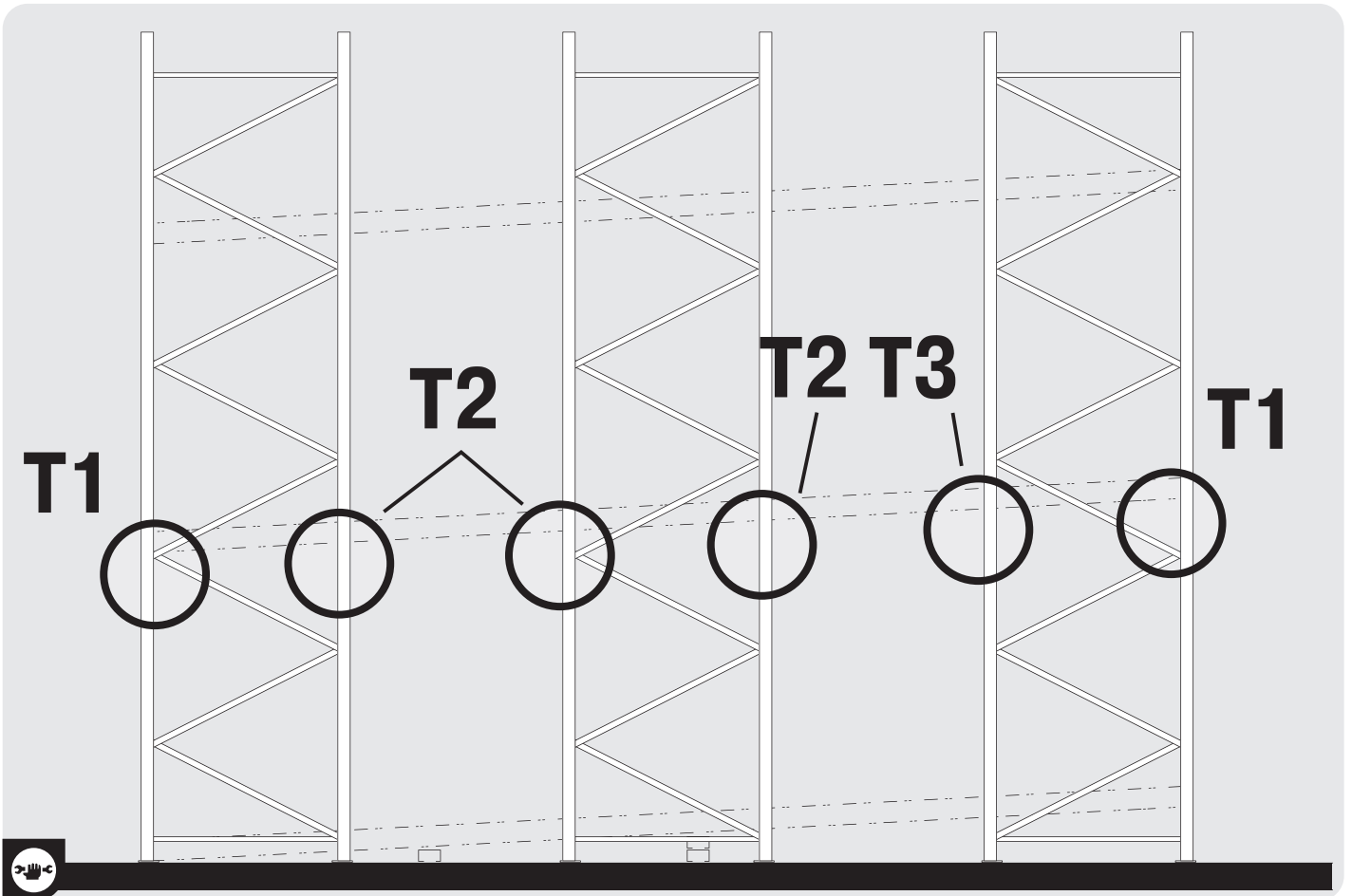
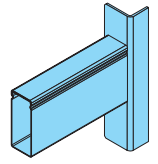

A

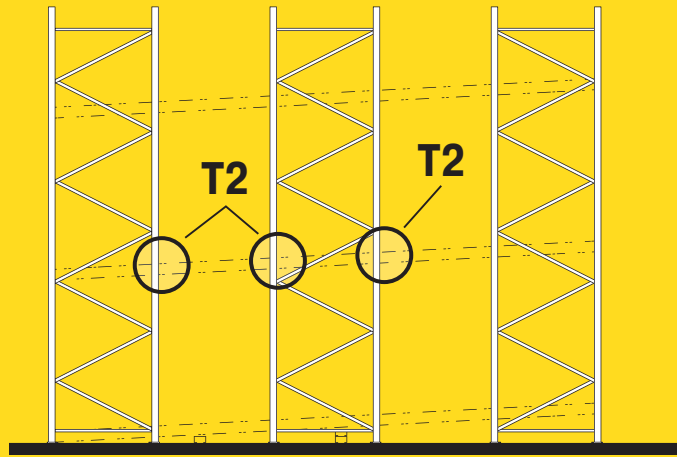

PROFLOW

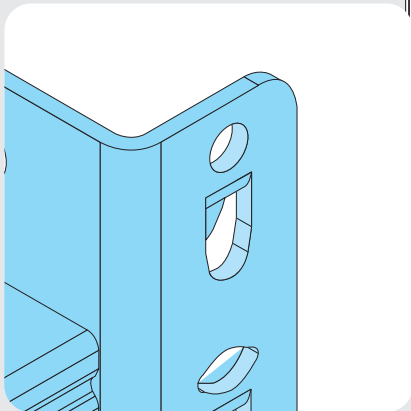
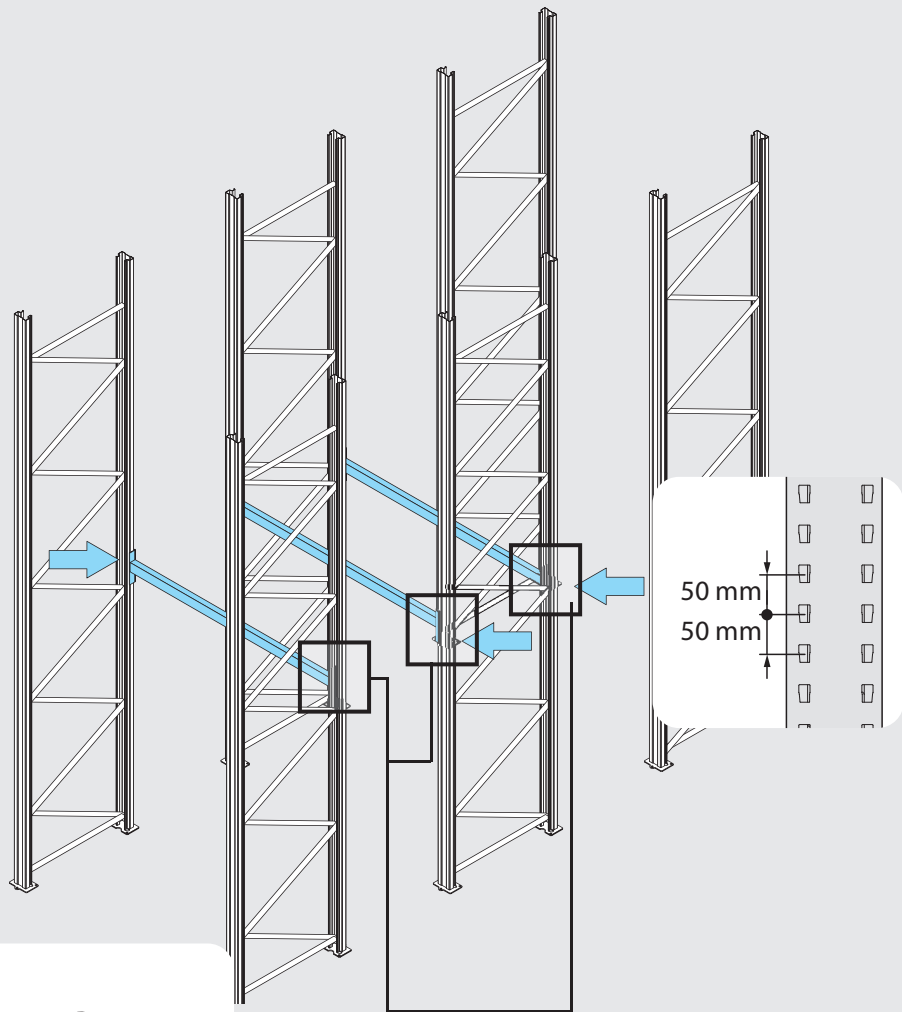

T2



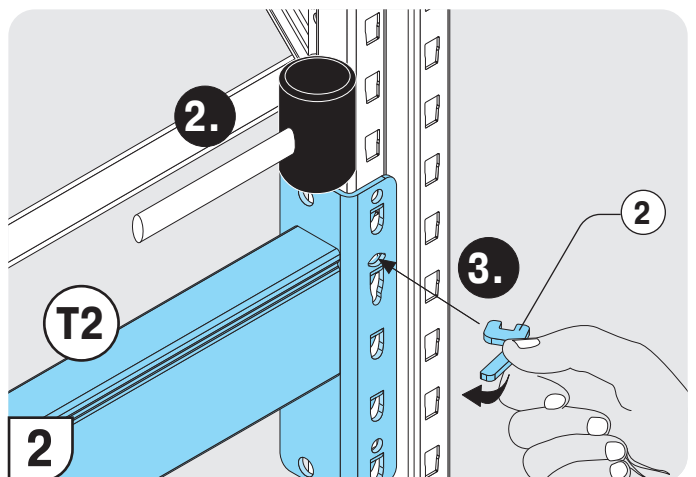
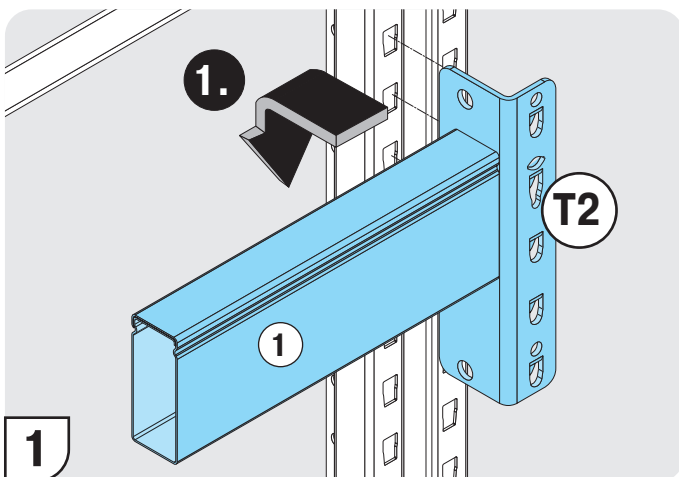
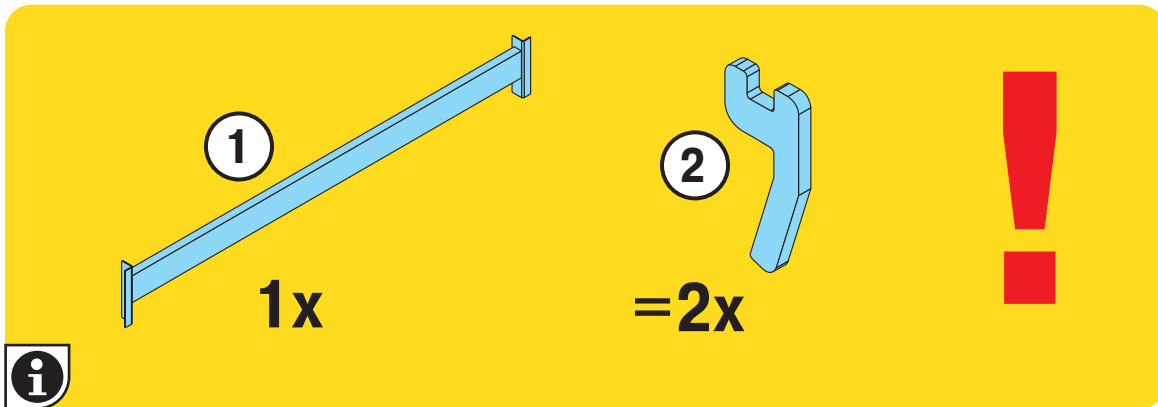
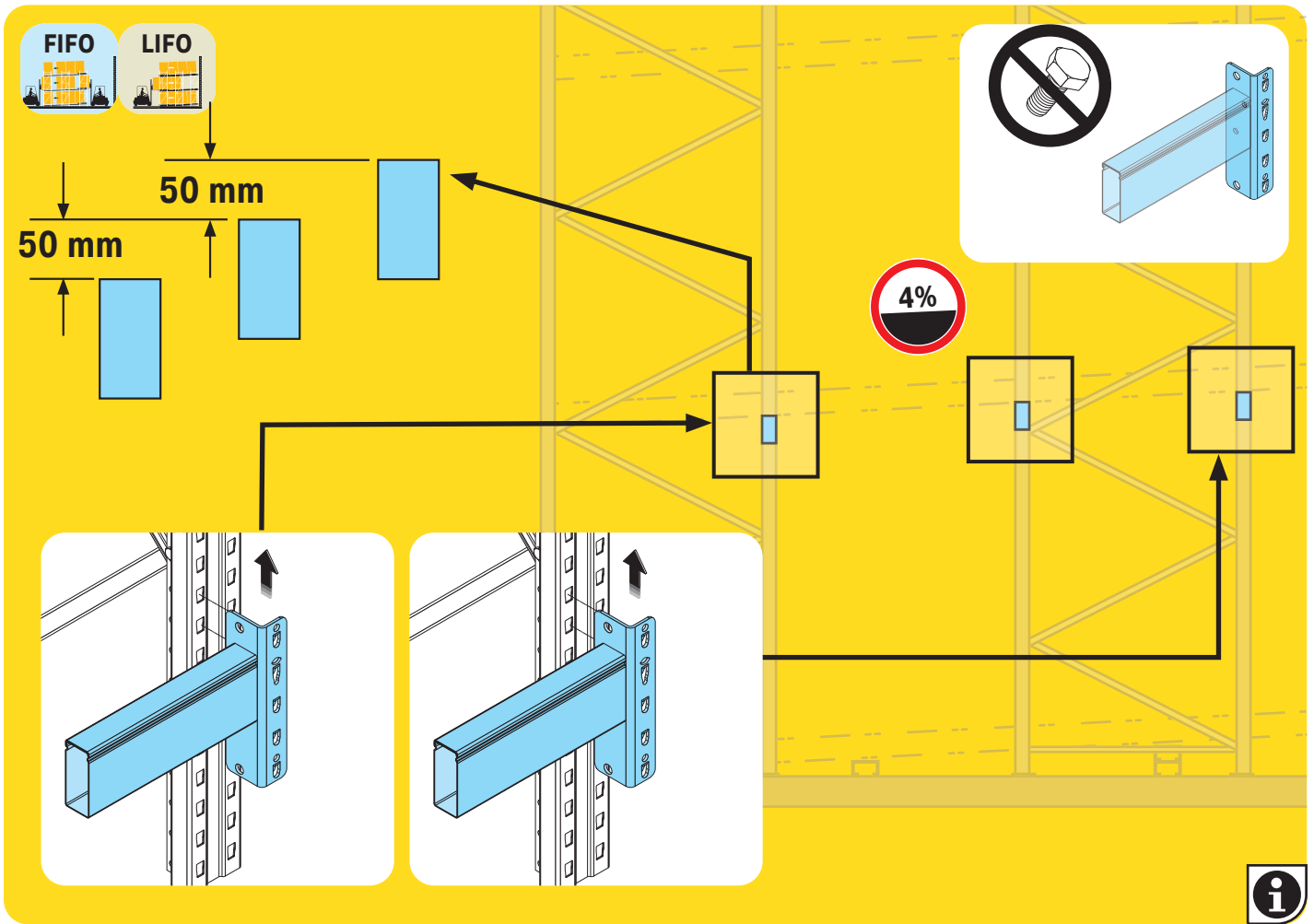

B

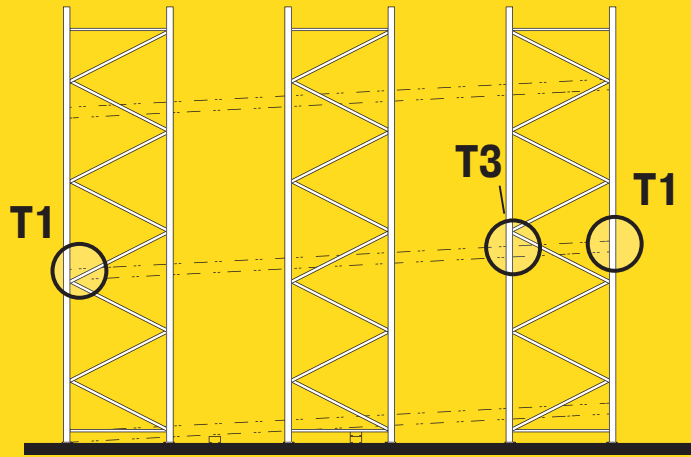

PROFLOW

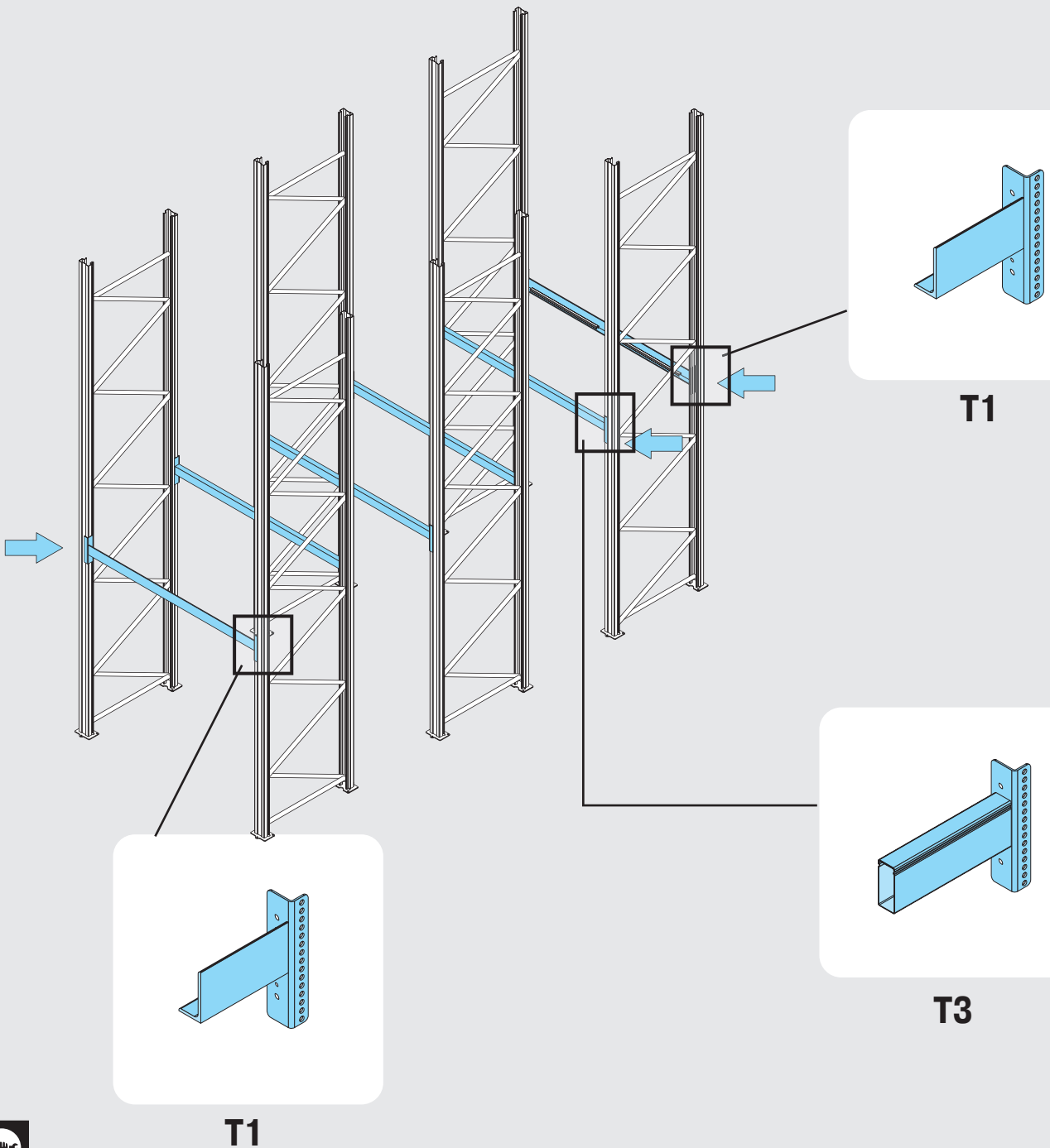

Stütze Upright

FIFO

LIFO

4 HV 10

2 HV 10.9

1		1 x =			
2		M12x30 mm DIN EN 14399-4	HV 10.9	6x	
3		230x30x4 mm		2x	
4		M12 mm DIN EN 14399-4	HV 10	6x	
5		DIN EN 14399-6		6x	

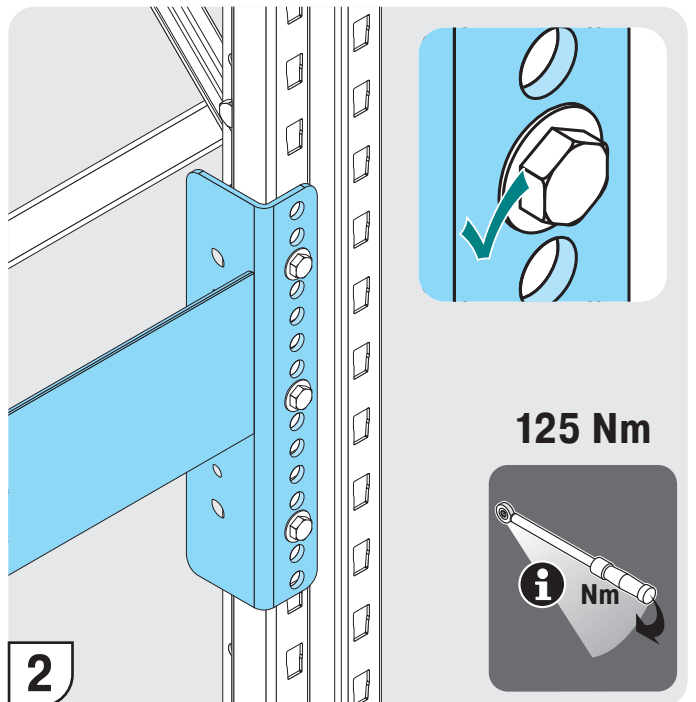
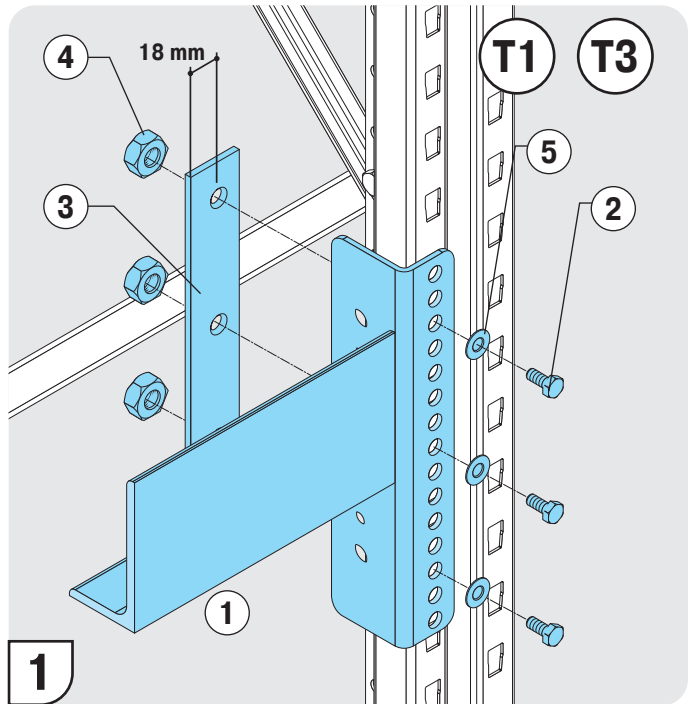

PROFLOW

C



PROFLOW

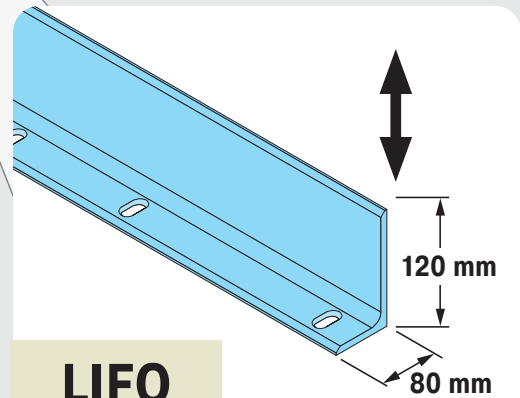
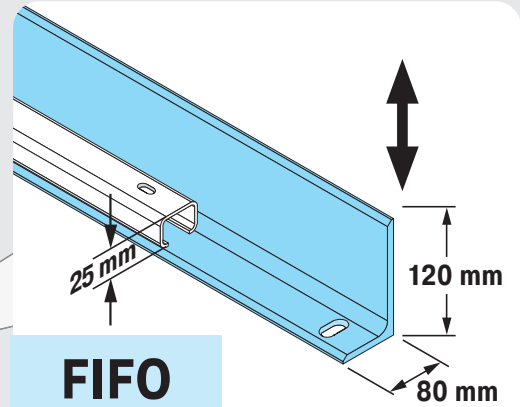
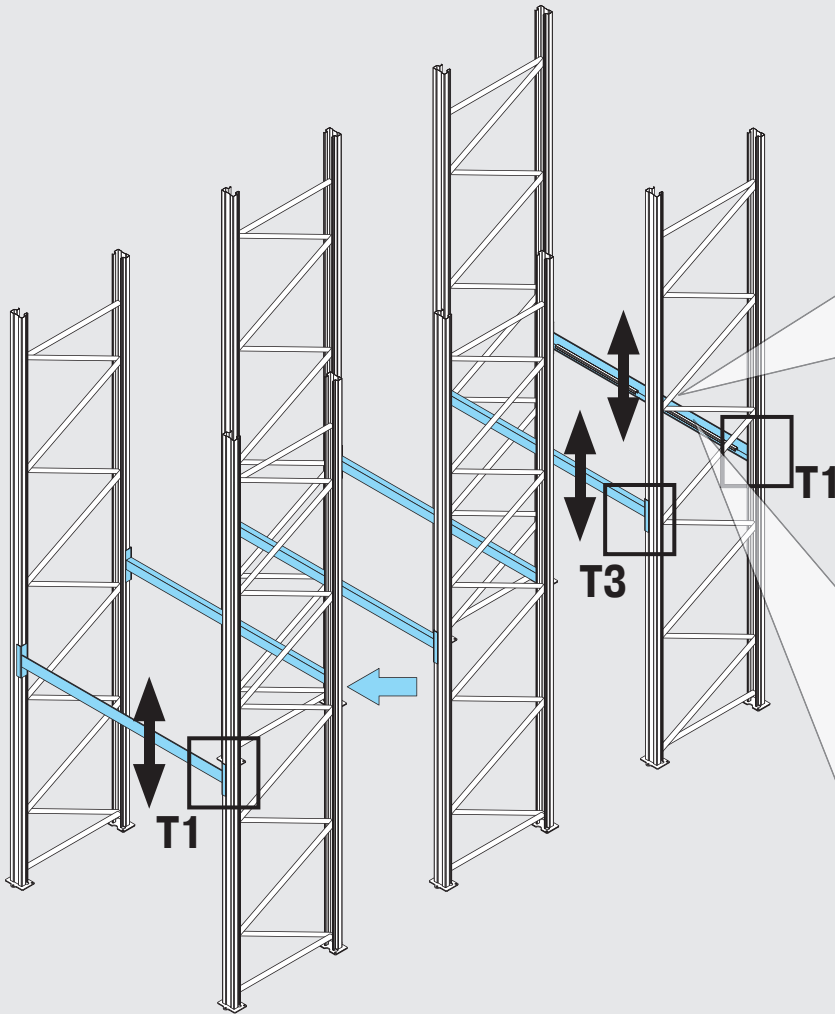

0 - 10 mm

40 - 50 mm

30 - 40 mm

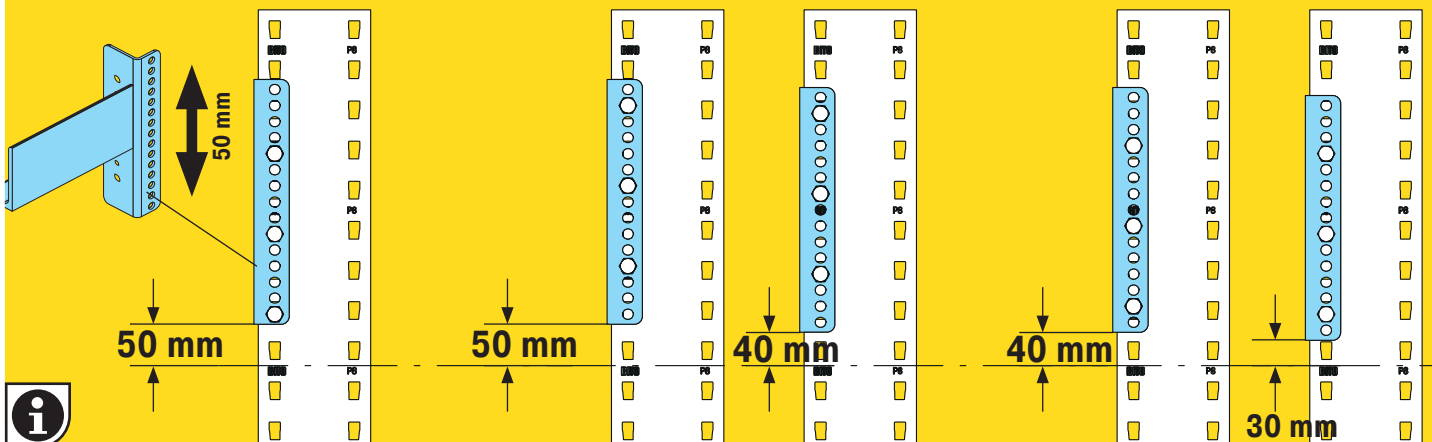

Stütze Upright

BITO



T1

T3

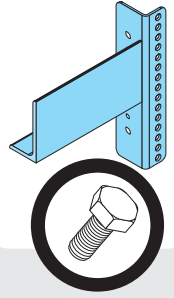
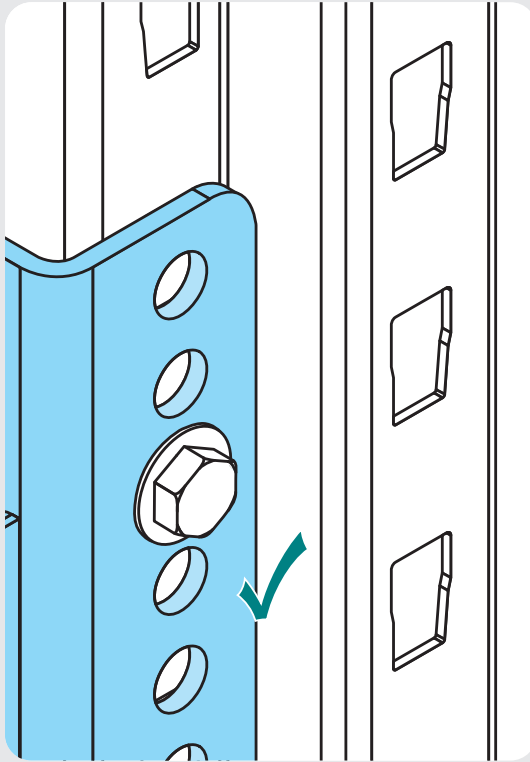
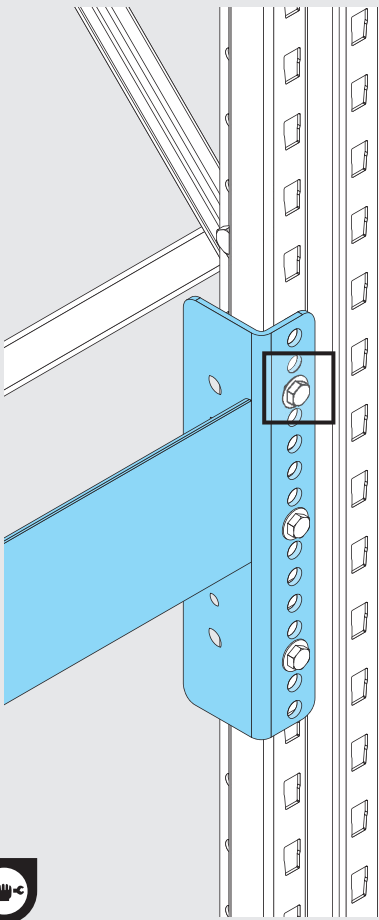

125 Nm



PROFLOW

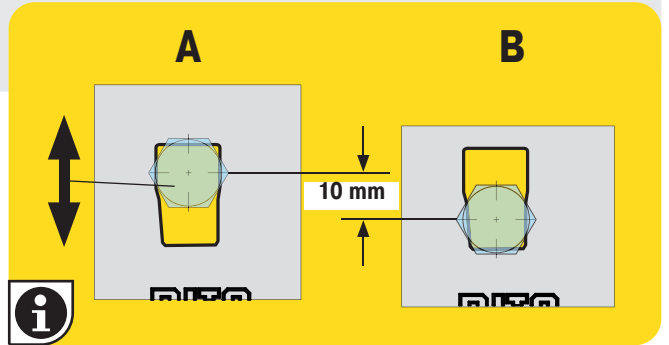

20 - 30 mm

10 - 20 mm

0 - 10 mm

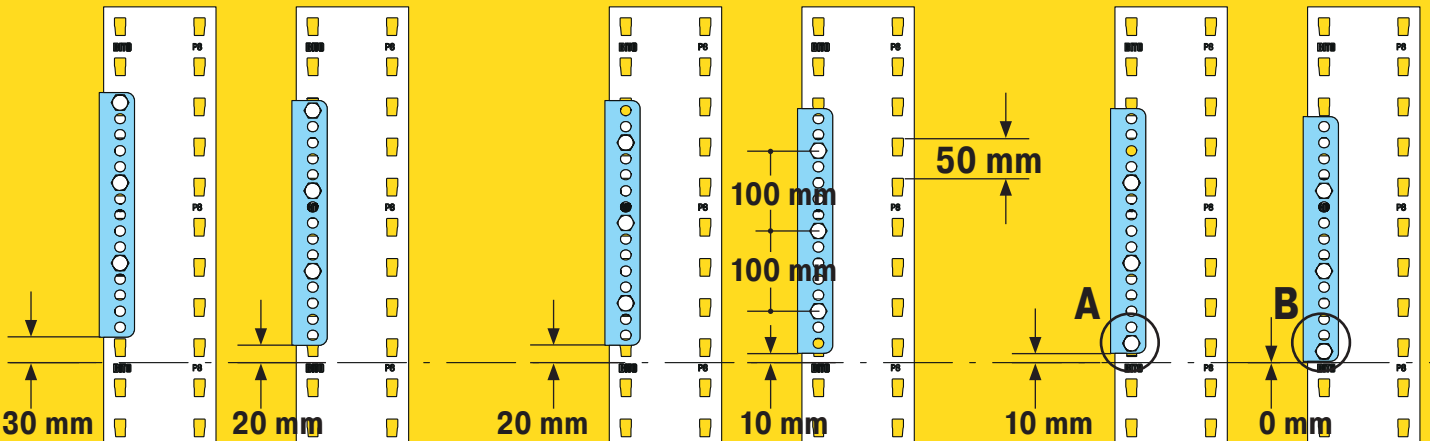



PROFLOW

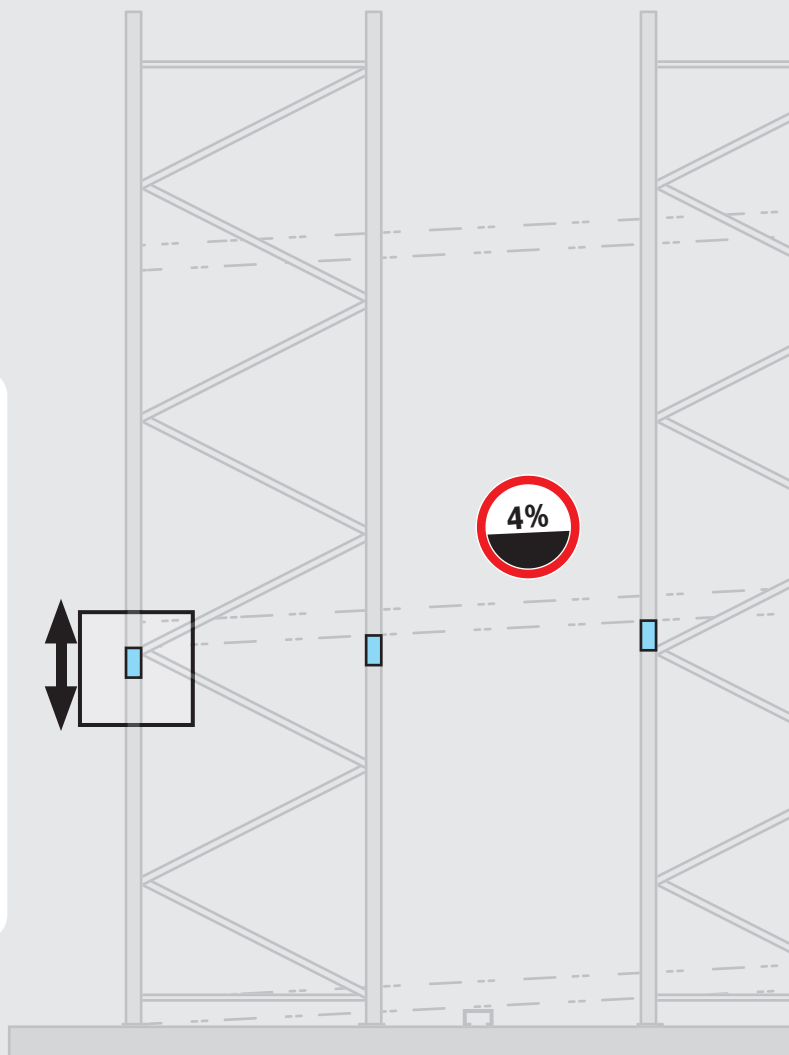
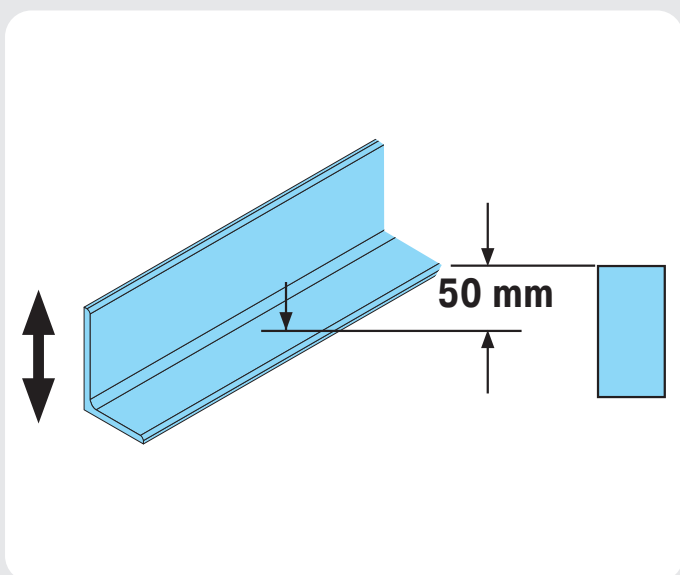

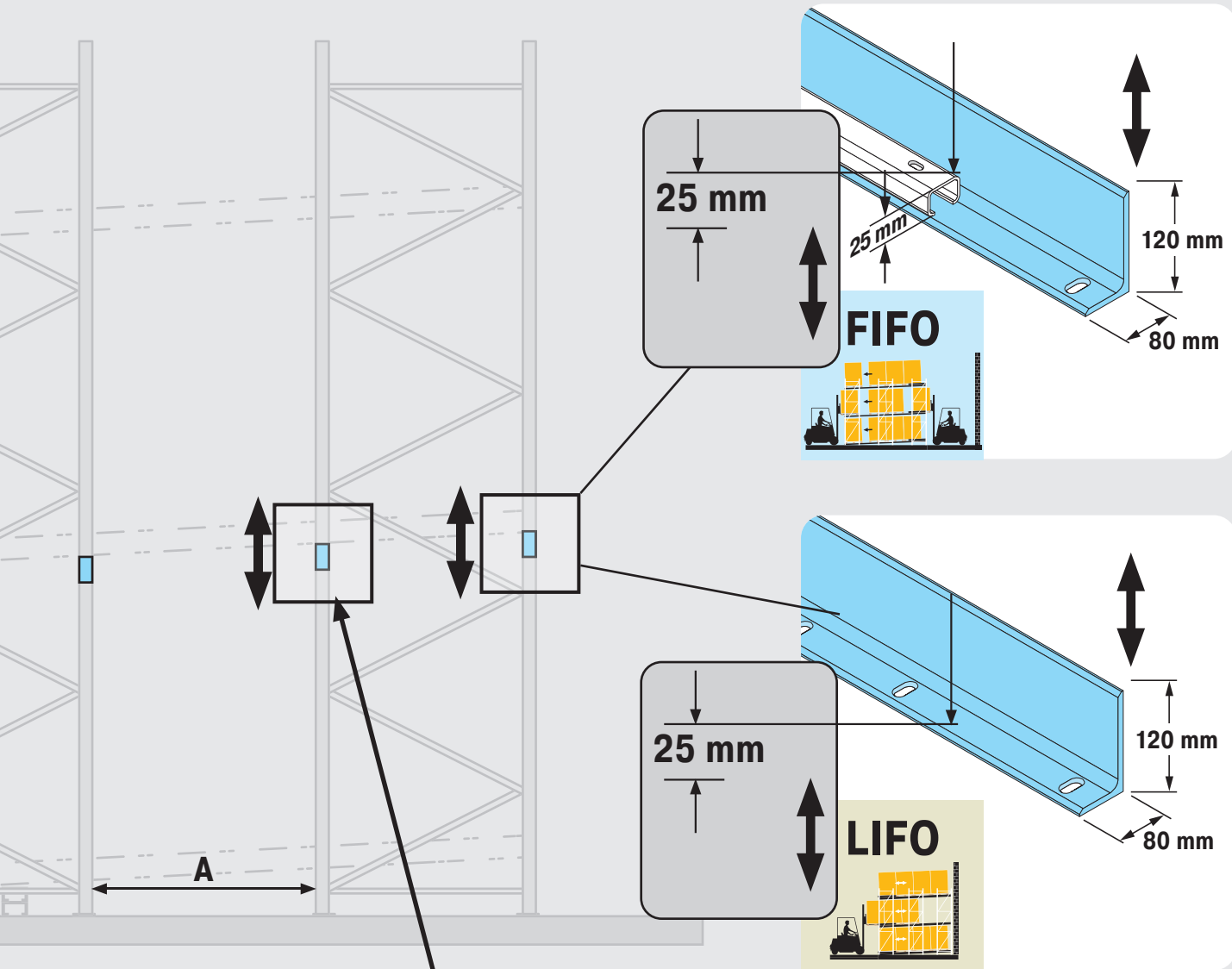

The diagram shows a cross-section of the upright with a 50 mm offset and a distance 'x' between the center of the upright and the center of the slot. The formula for calculating 'x' is:

$$x = \frac{(A + 50) \times 4}{100}$$

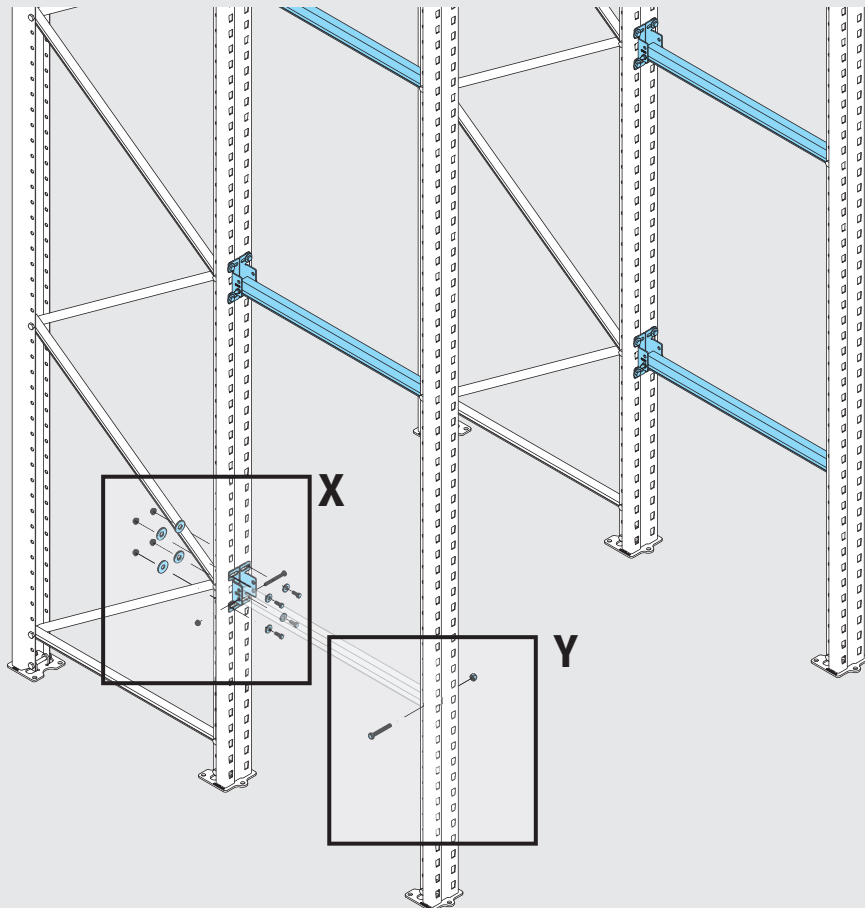
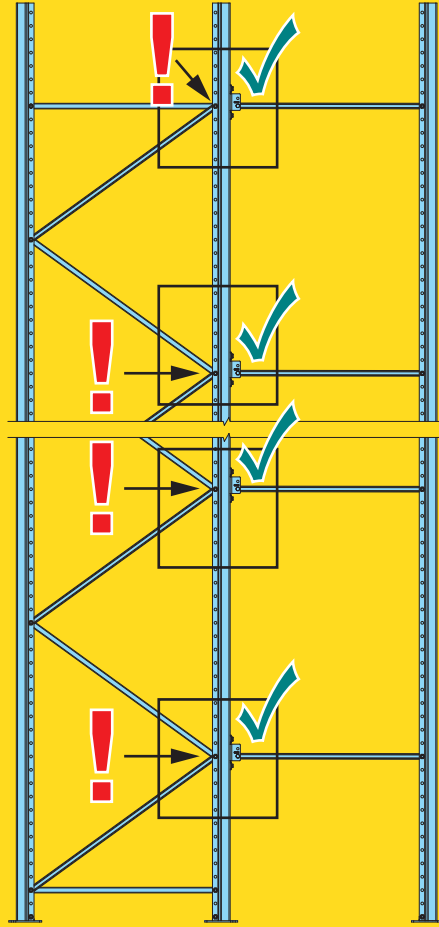

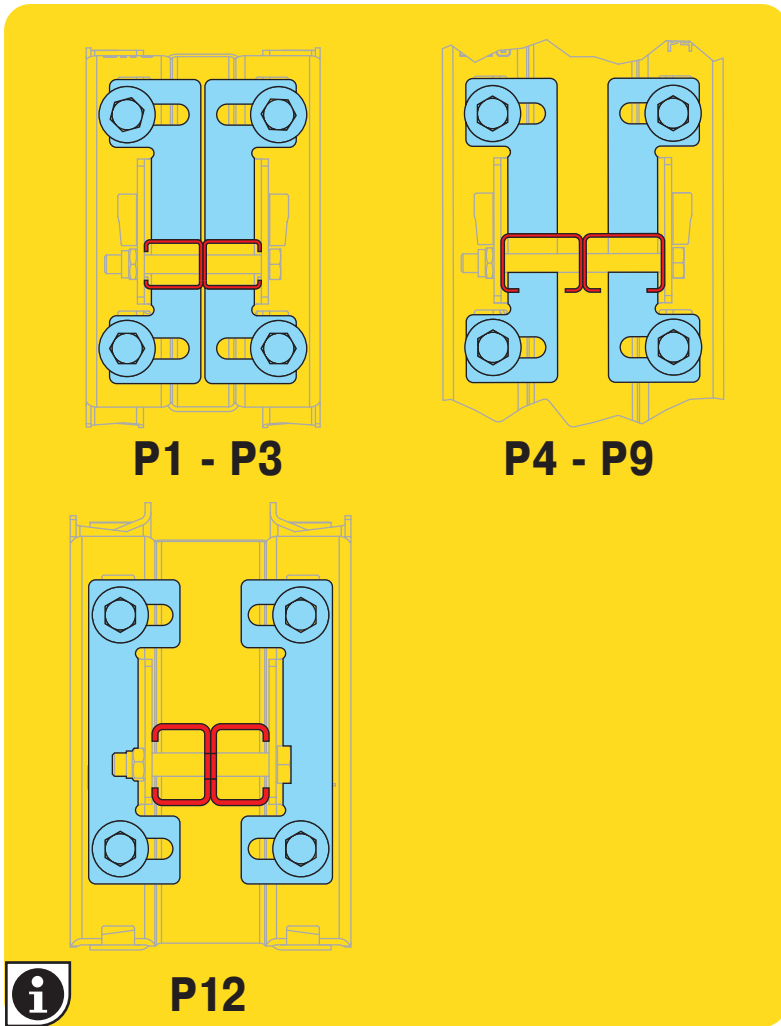

①	22835		ISO 4014 M10 x 65	8.8	1
	P1 - P3 + P12				
①	22836		ISO 4014 M10 x 90	8.8	1
	P4 - P9				
②	22960		ISO 7042 M10	8	1
③	25133		130 x 39 x 38 mm		2
④			C 21 x 1.45 x L mm		2
⑤	03345		ISO 4017 M8 x 20	8.8	4
⑥	03323		ISO 4014 M 8 x 70	8.8	1
	P1 - P3 + P12				
⑥	26873		ISO 4014 M 8 x 90	8.8	1
	P4 - P9				
⑦	03399		ISO 7042 M 8	8	1
⑧	03404		EN 1661	8	4
⑨	03426		ISO 7093-1	8	8

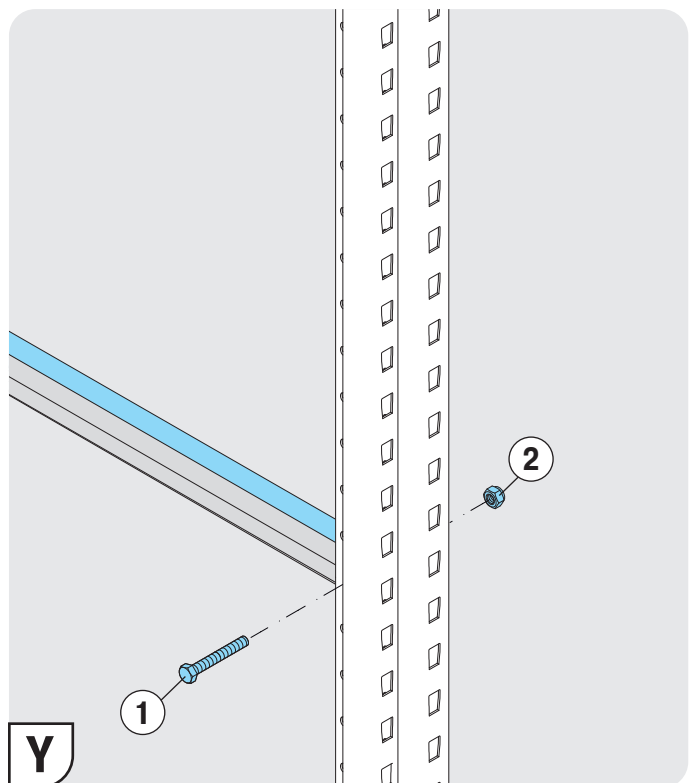
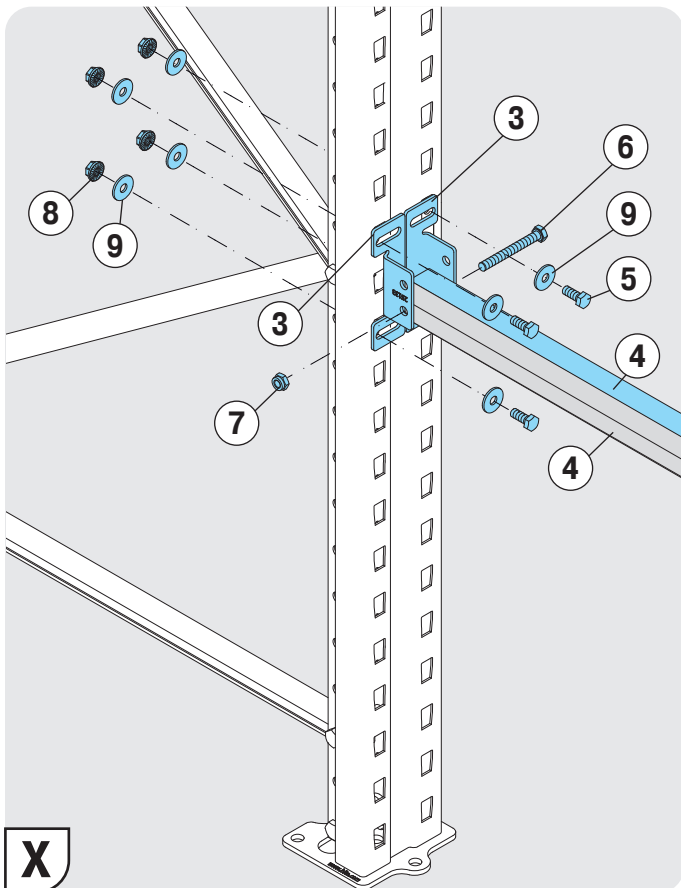

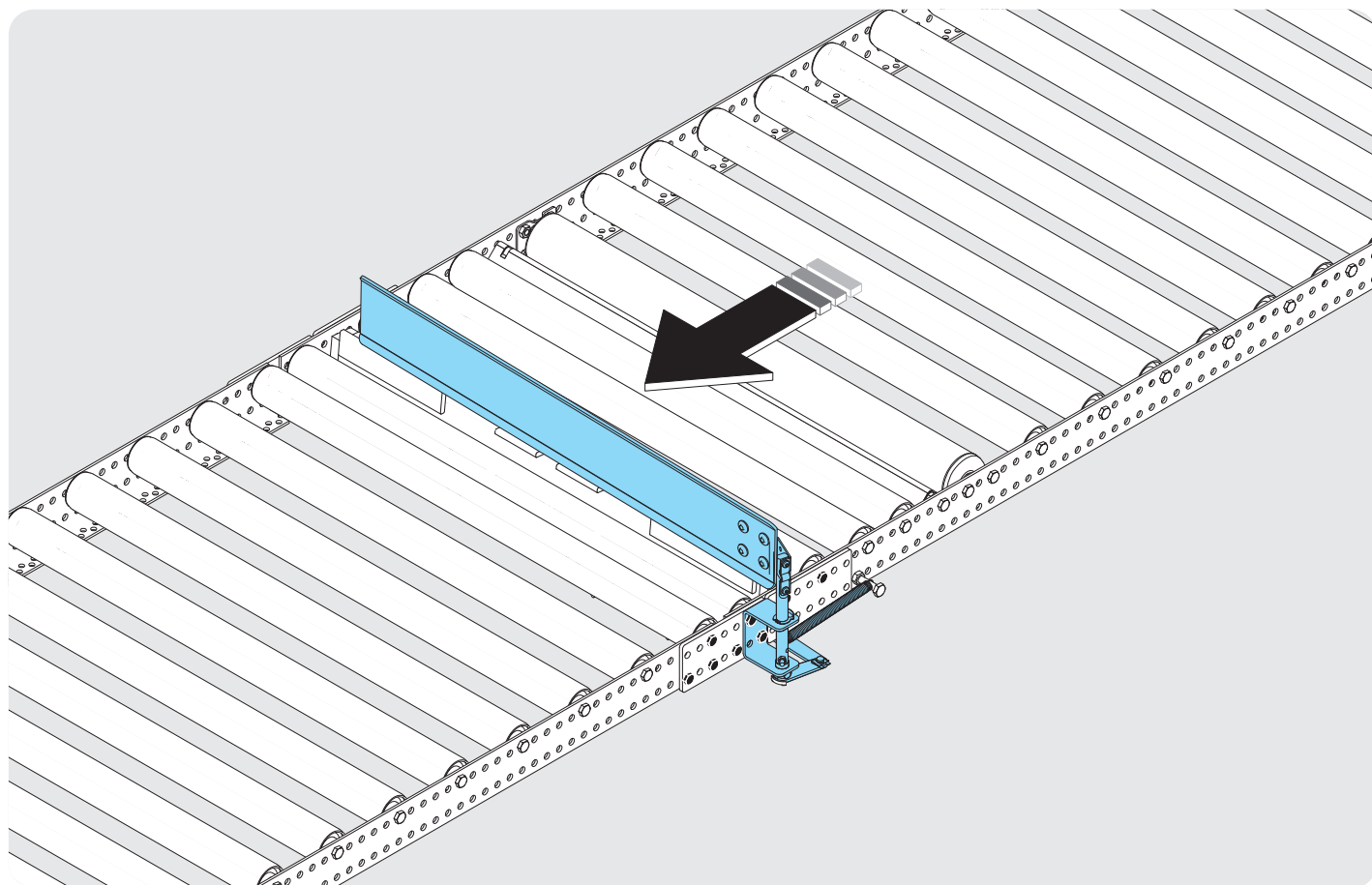
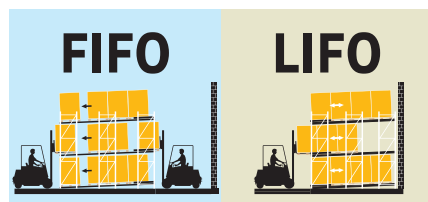

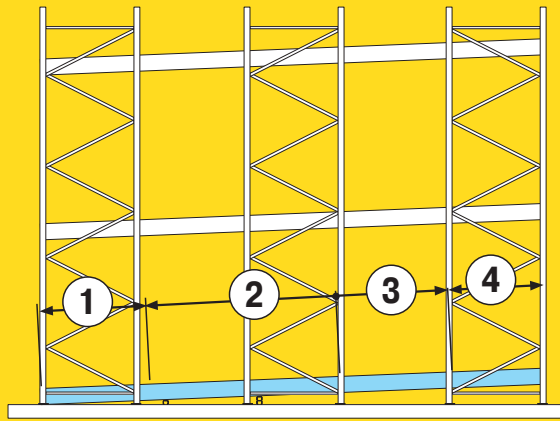

1

1296 mm

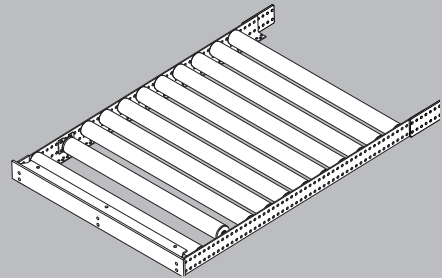

2

2496 mm

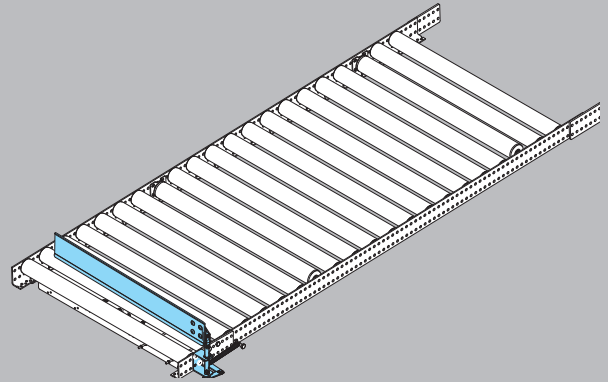

3

312 - 2184 mm

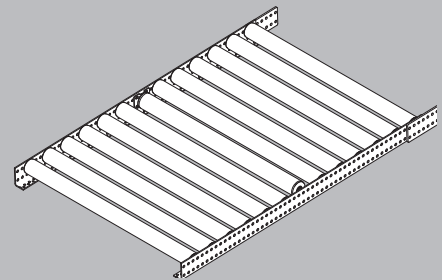

4

1272 mm

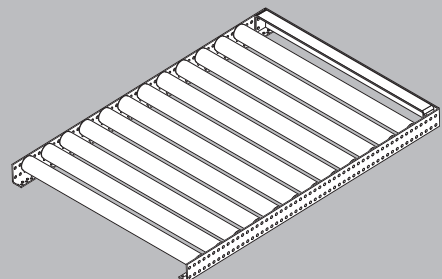

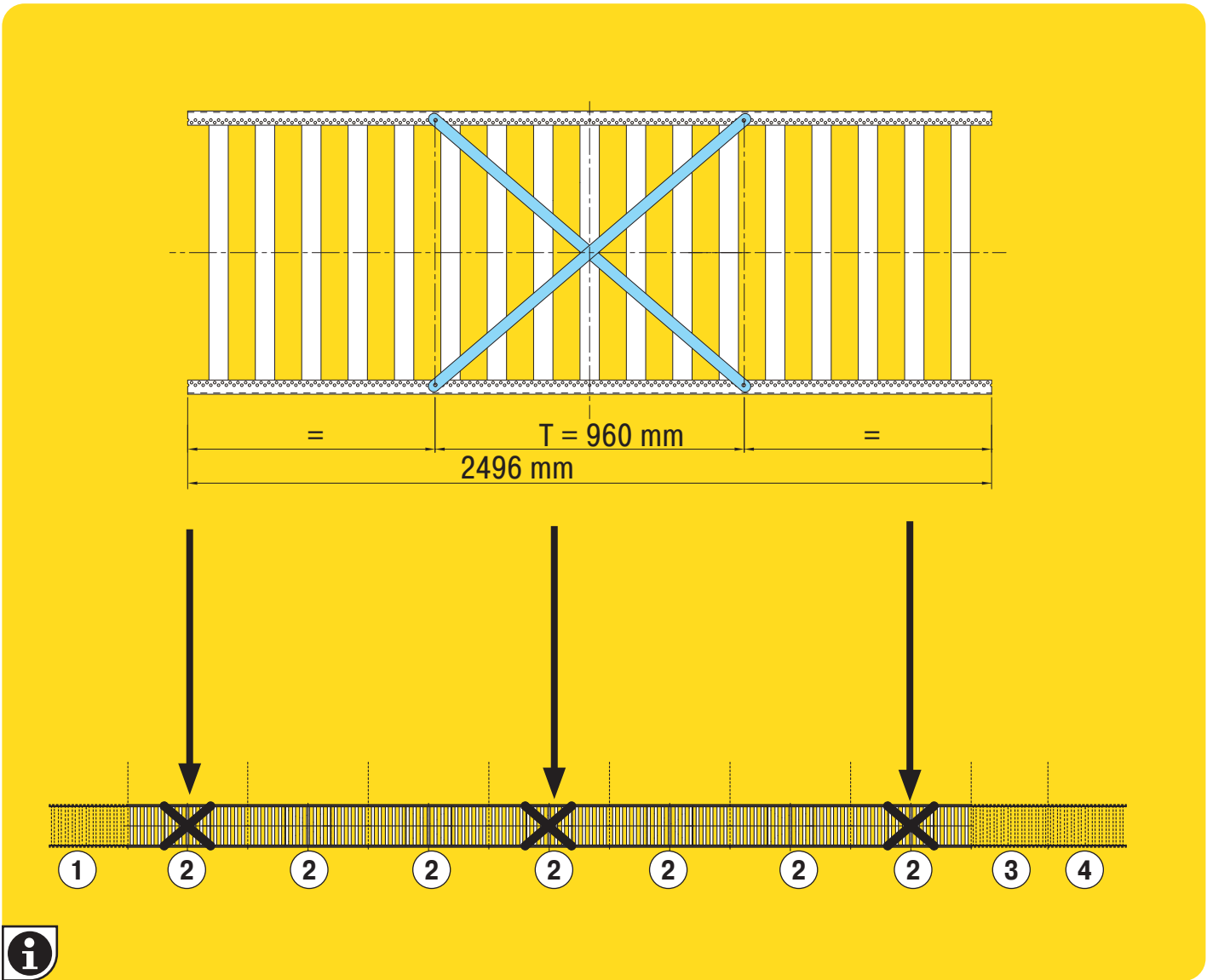
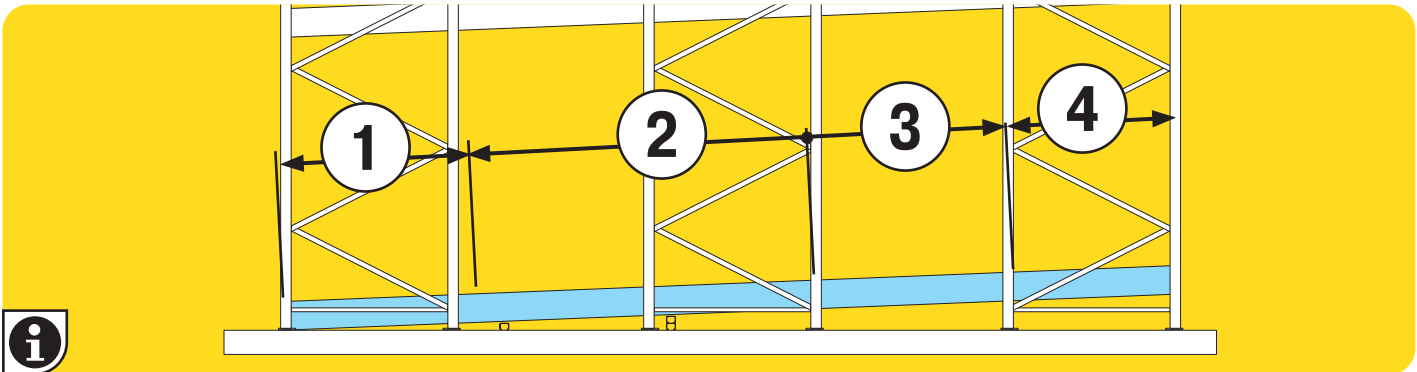
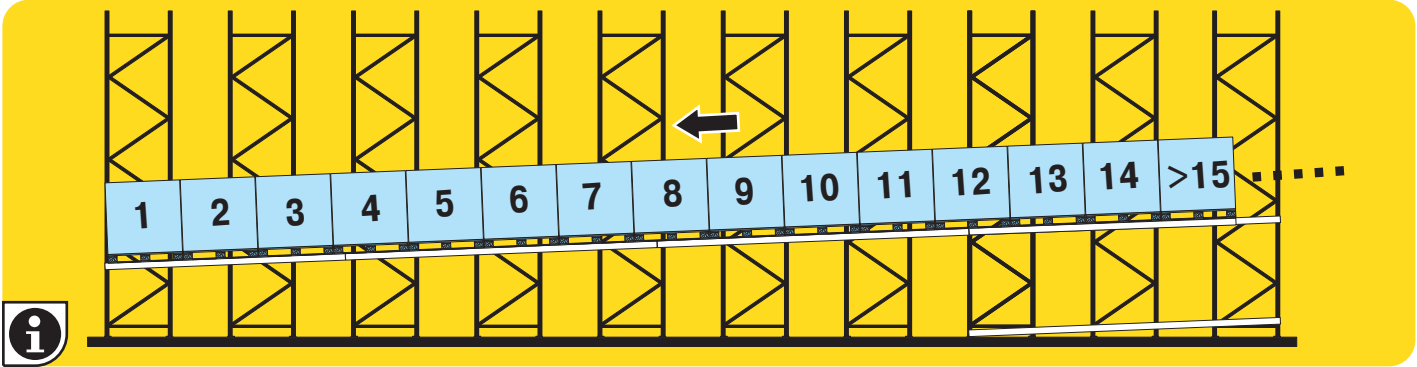

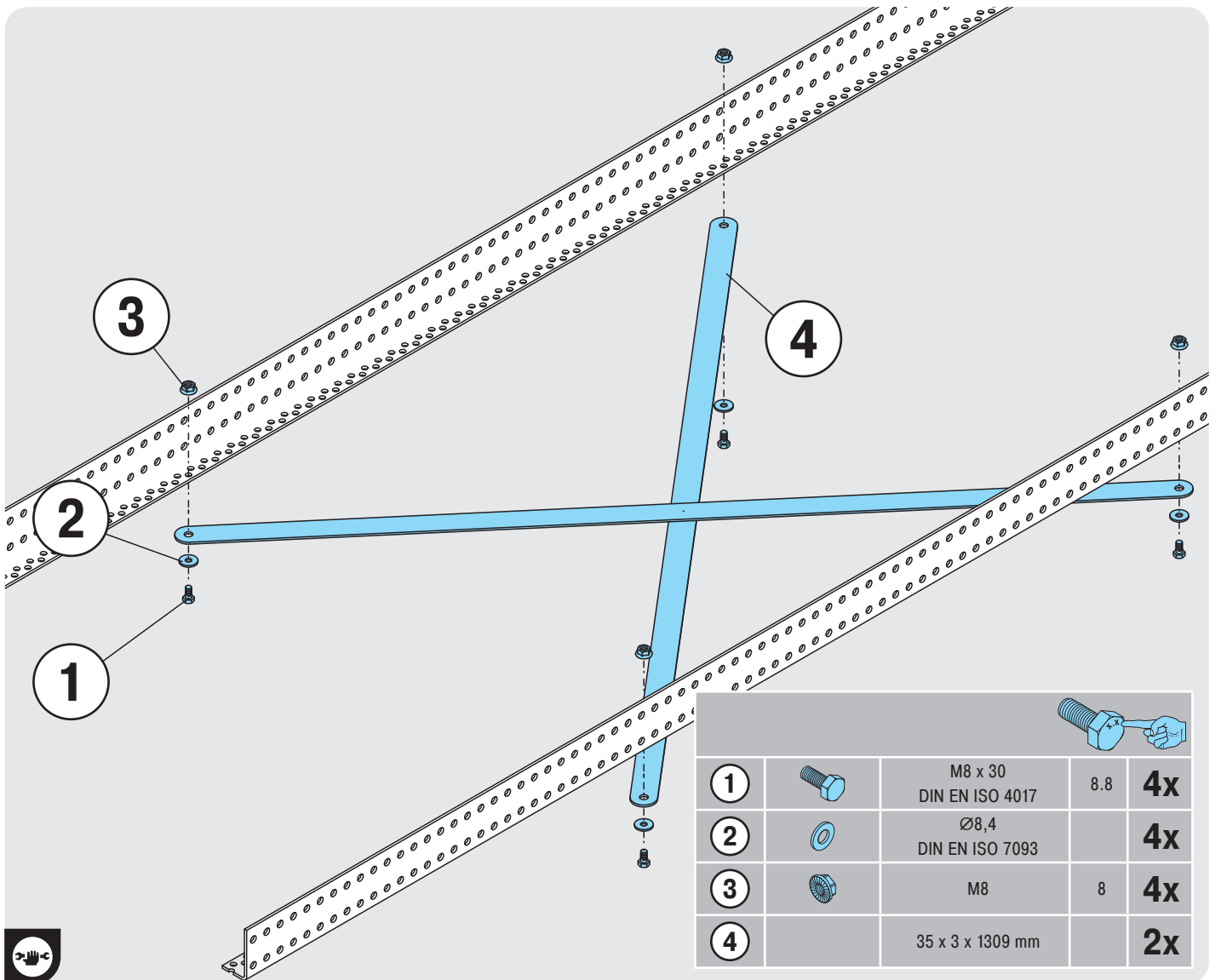

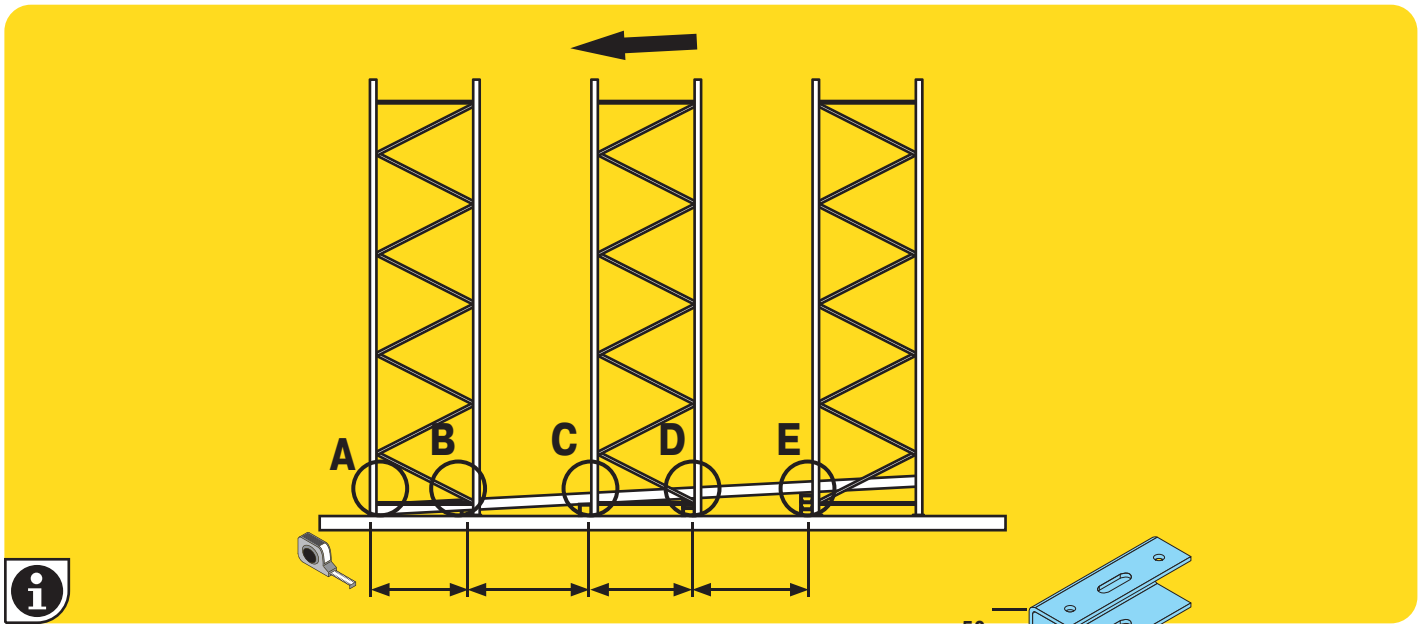

50 mm

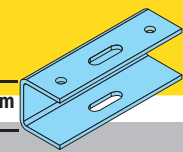

1		Ø10,5 DIN EN ISO 7093		2x
2		M10 DIN EN ISO 4032	8	6x
3		M10 x 90 mm DIN EN ISO 4017	8.8	2x
Y		M10 x 20 mm		2x

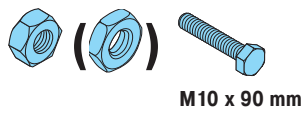

X					2x
1		Ø10,5 DIN EN ISO 7093			6x
2		M10 DIN EN ISO 4032	8		6x
3		M8 x 20 mm DIN EN ISO 4032	8.8		4x
4		M8	8		4x
5		M10 x 65mm DIN EN ISO 4017	8.8		2x
6		M10 x 90 mm DIN EN ISO 4017	8.8		2x
Y		M10 x 20 mm	8		2x

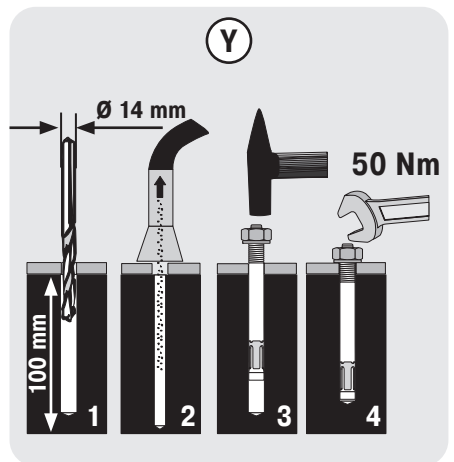
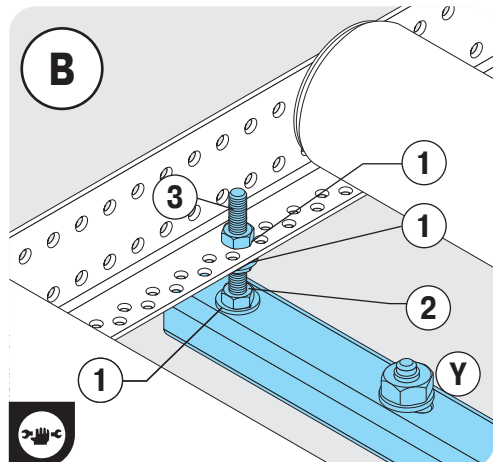
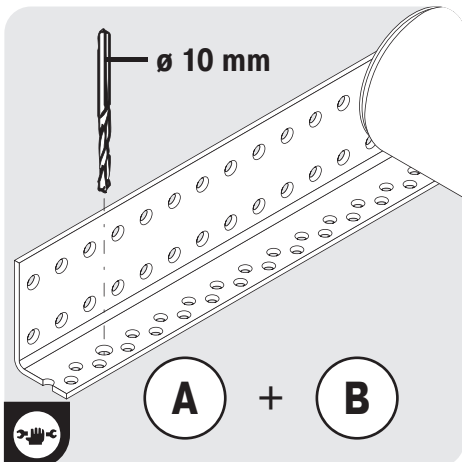
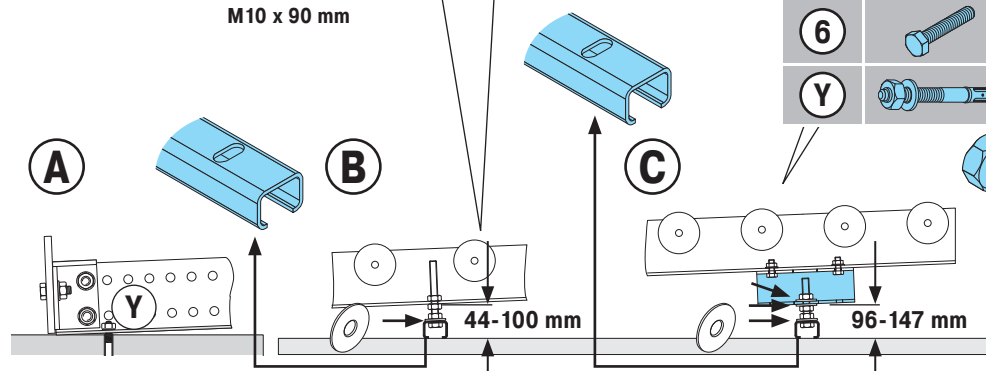

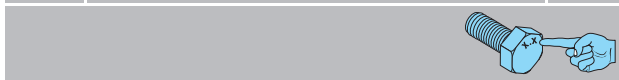
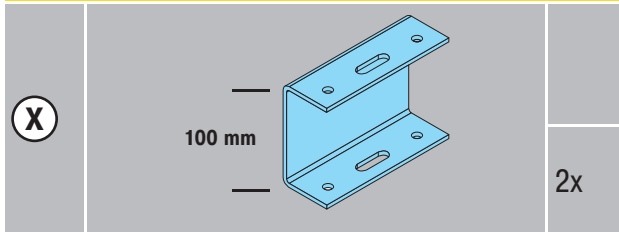
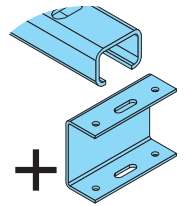

1		Ø10,5 DIN EN ISO 7093		6x
2		M10 DIN EN ISO 4032	8	6x
3		M8 x 20 mm DIN EN ISO 4032	8.8	4x
4		M8	8	4x
5		M10 x 90 mm DIN EN ISO 4017	8.8	2x
Y		M10 x 20 mm		2x

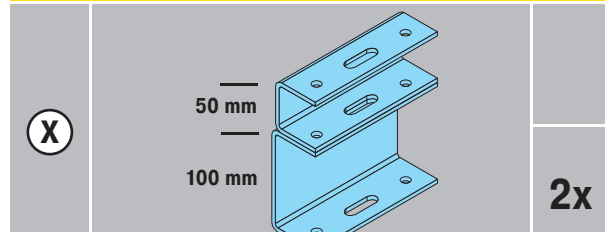

1		Ø10,5 DIN EN ISO 7093		6x
2		M10 DIN EN ISO 4032	8	6x
3		M8 x 20 mm DIN EN ISO 4032	8.8	8x
4		M8	8	8x
6		M10 x 90 mm DIN EN ISO 4017	8.8	2x
Y		M10 x 20 mm		2x

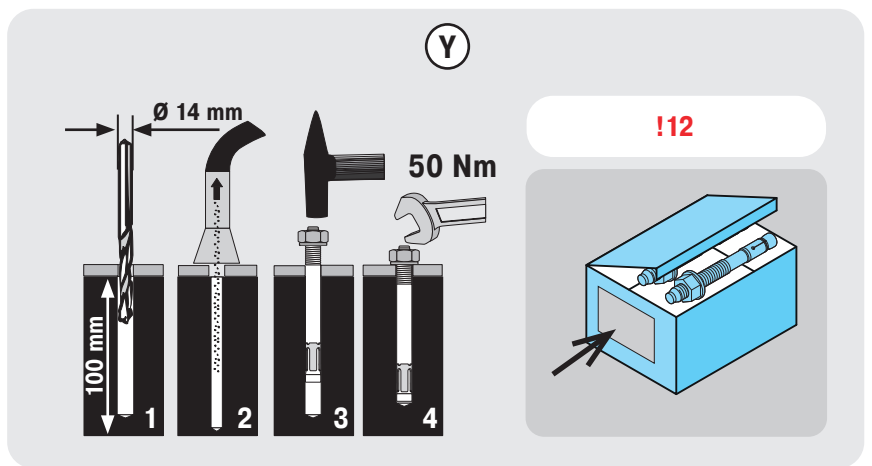
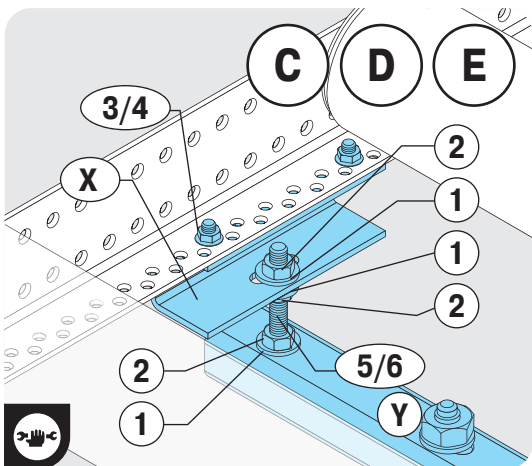
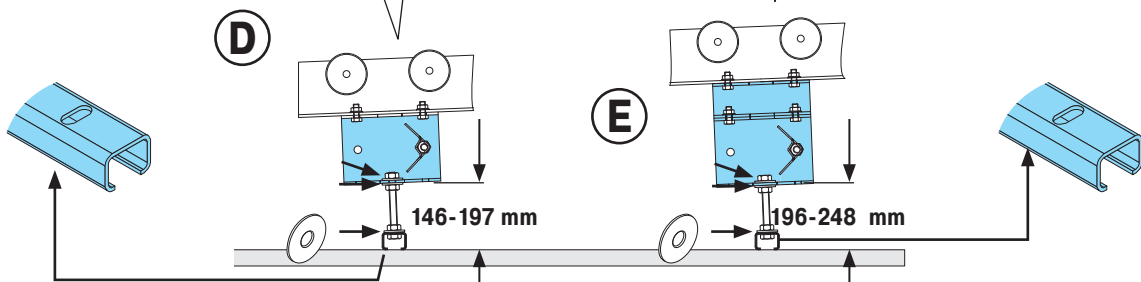

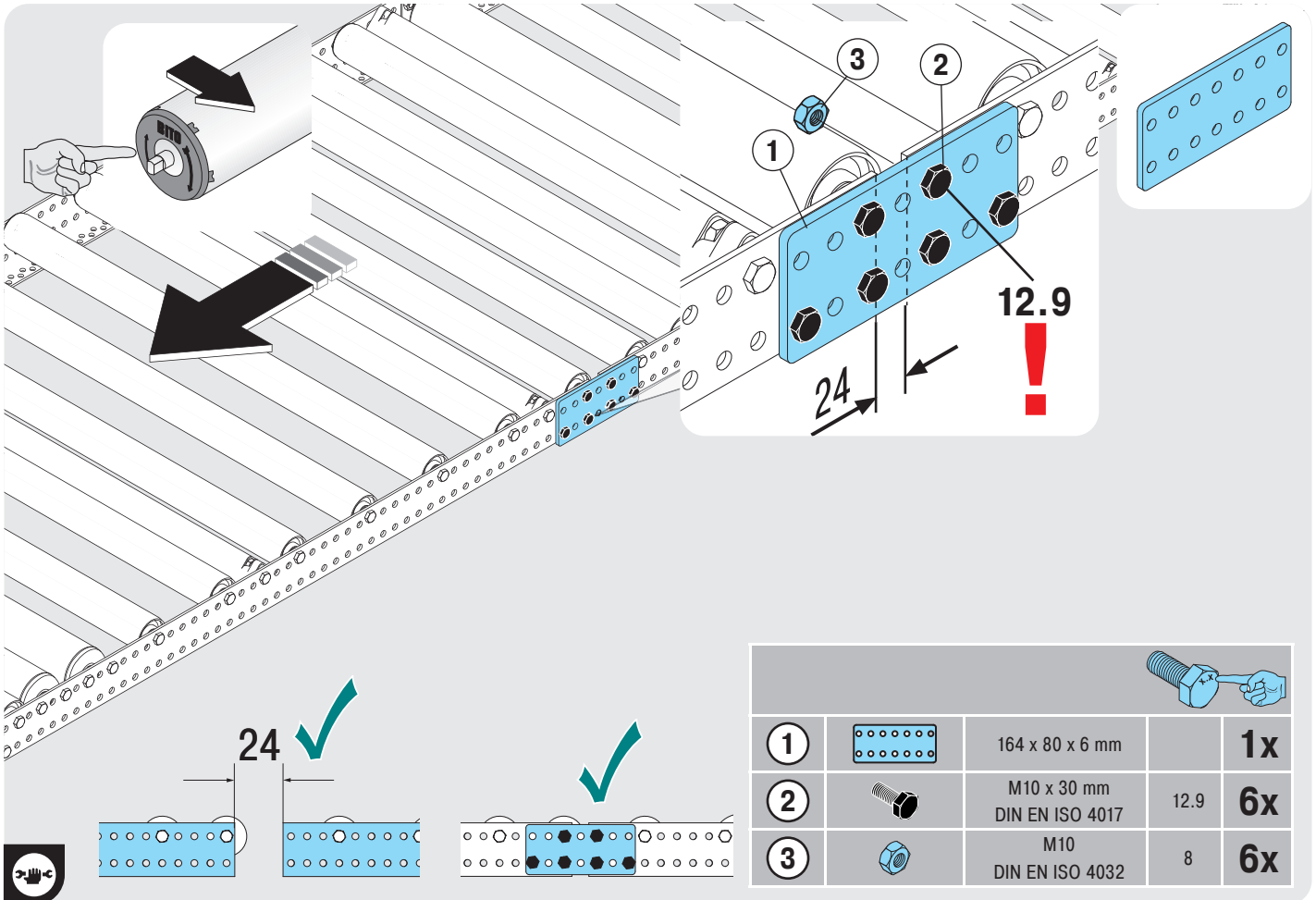
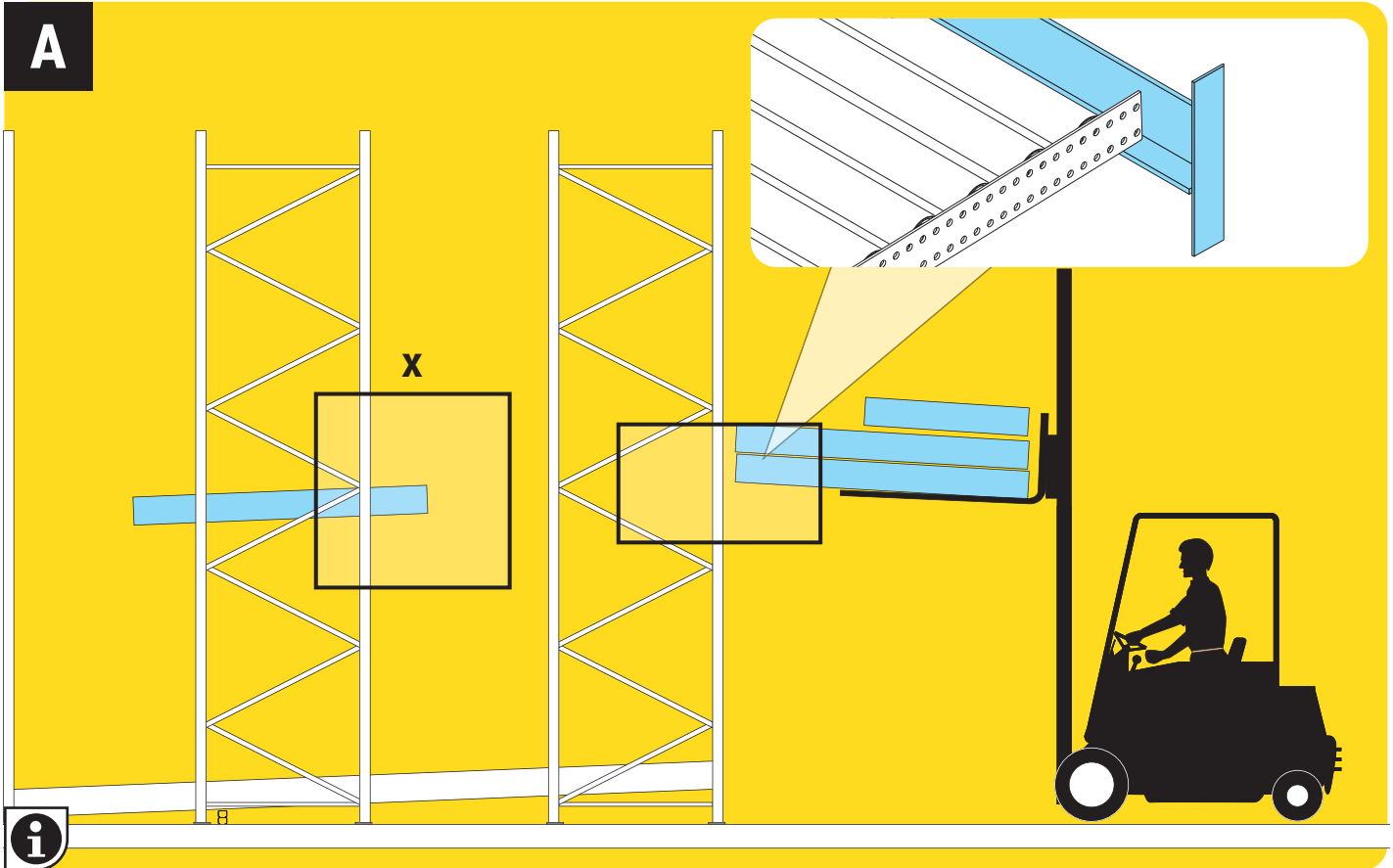

B

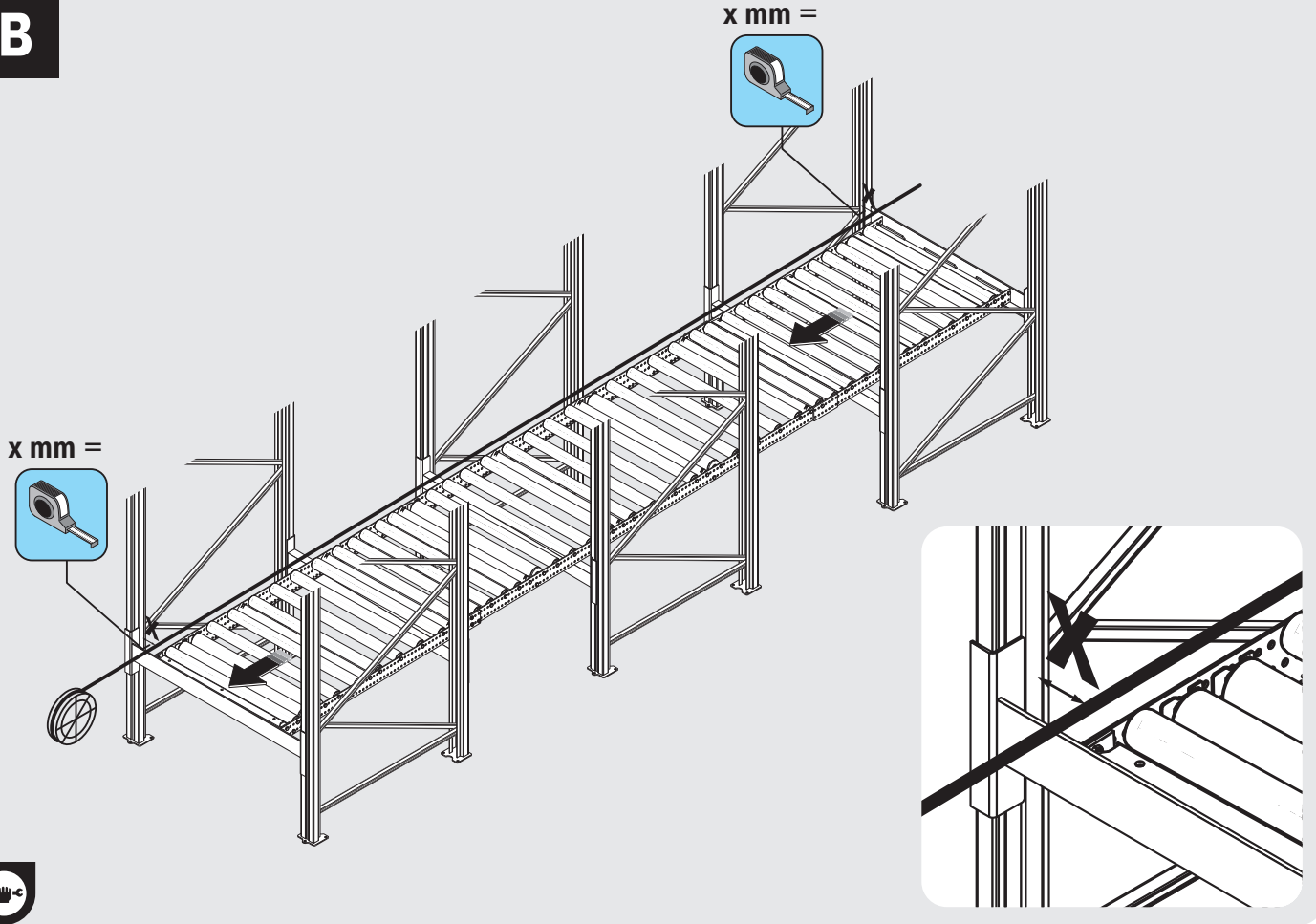

B

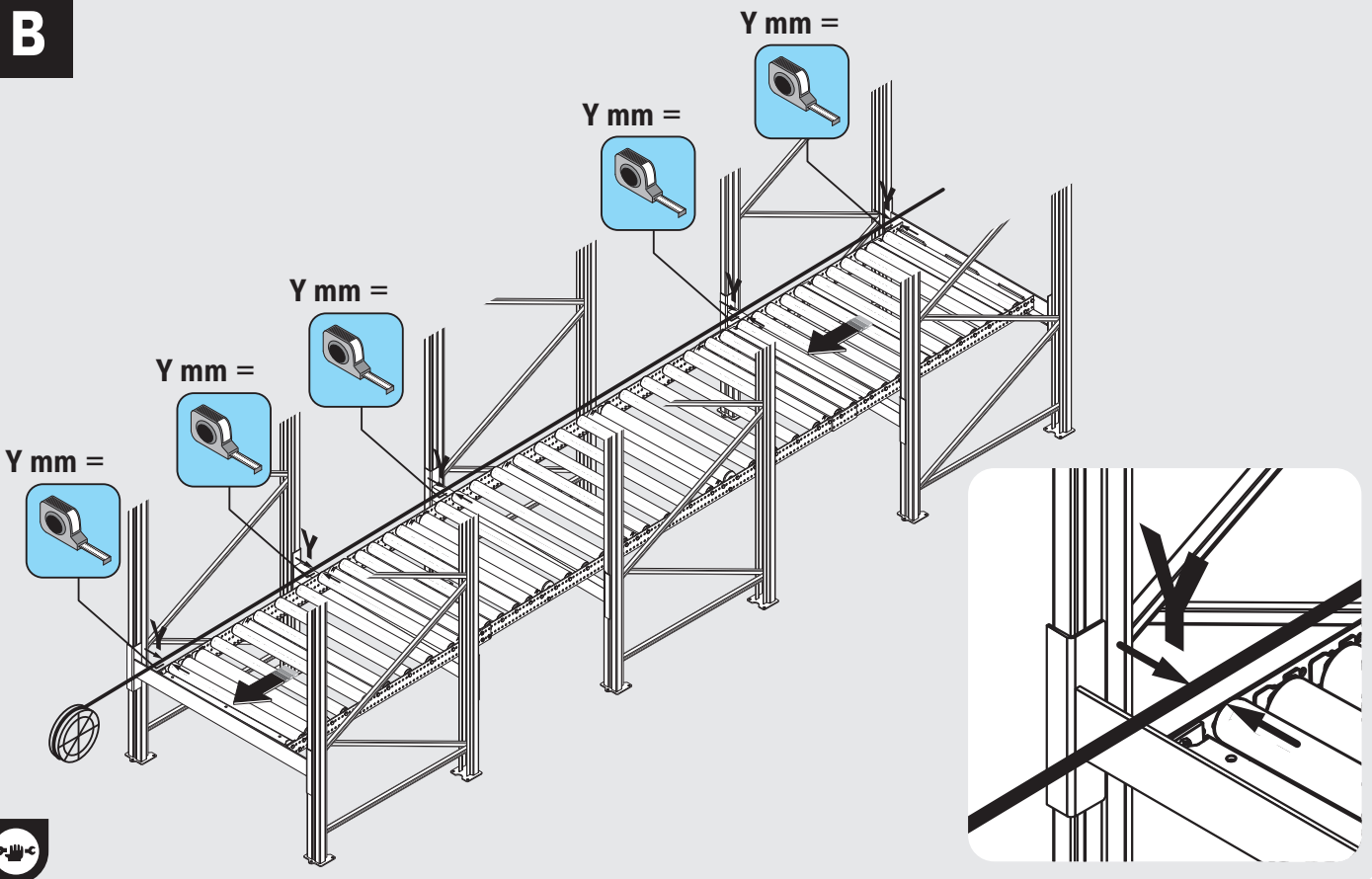



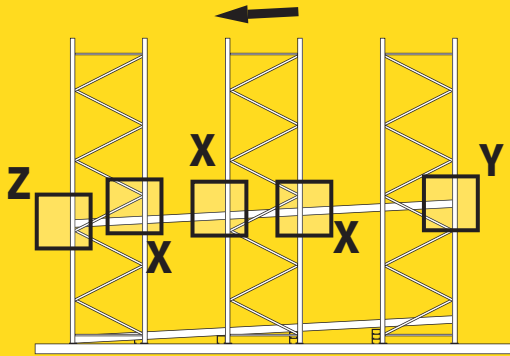

PROFLOW

C

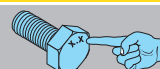

PROFLOW



					
1		M8 x 30 DIN EN ISO 4017	8.8	2x	
2		Ø8,4 DIN EN ISO 7089		2x	
3		M8	8	2x	
4		ø6,3 x 19N DIN EN ISO 15483		2x	

C

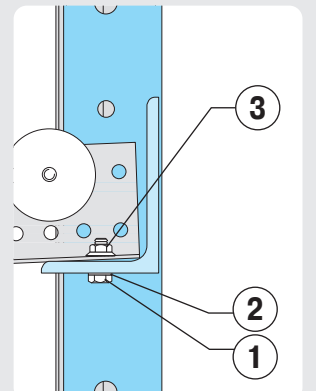
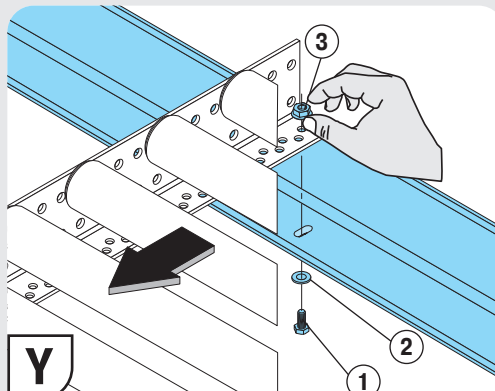
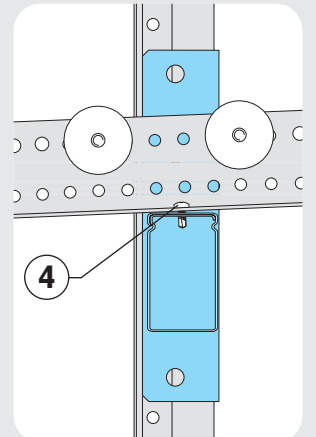
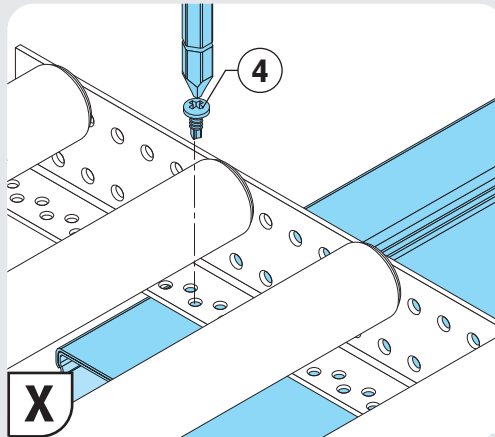
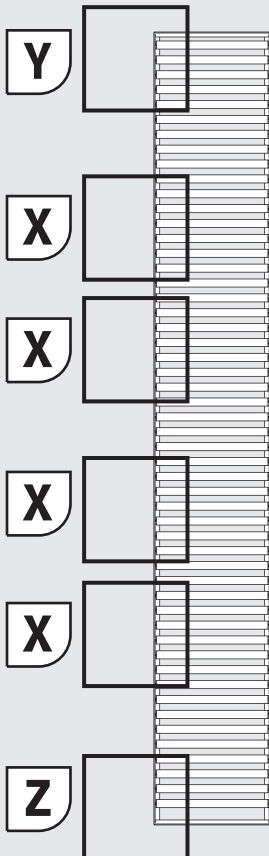

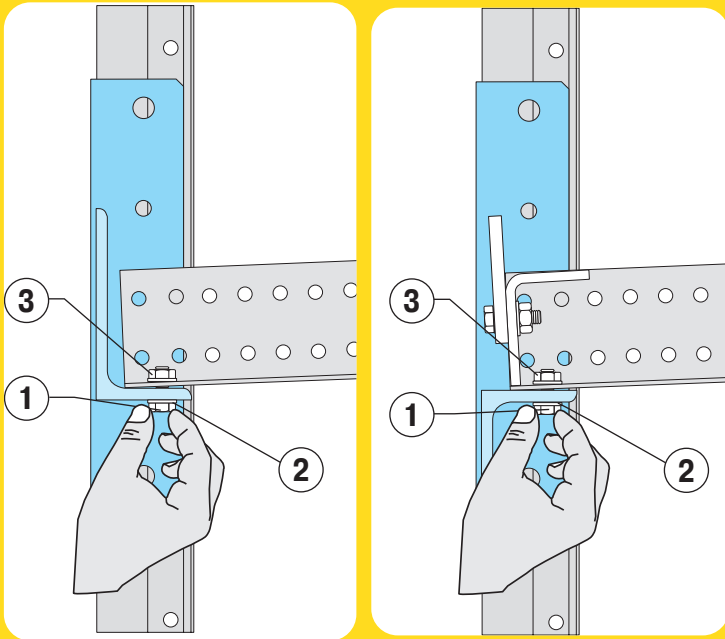
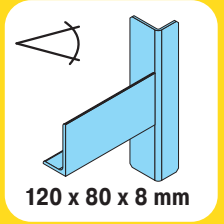

1		M8 x 30 DIN EN ISO 4017	8.8	2x
2		Ø8,4 DIN EN ISO 7089		2x
3		M8	8	2x

PROFLOW

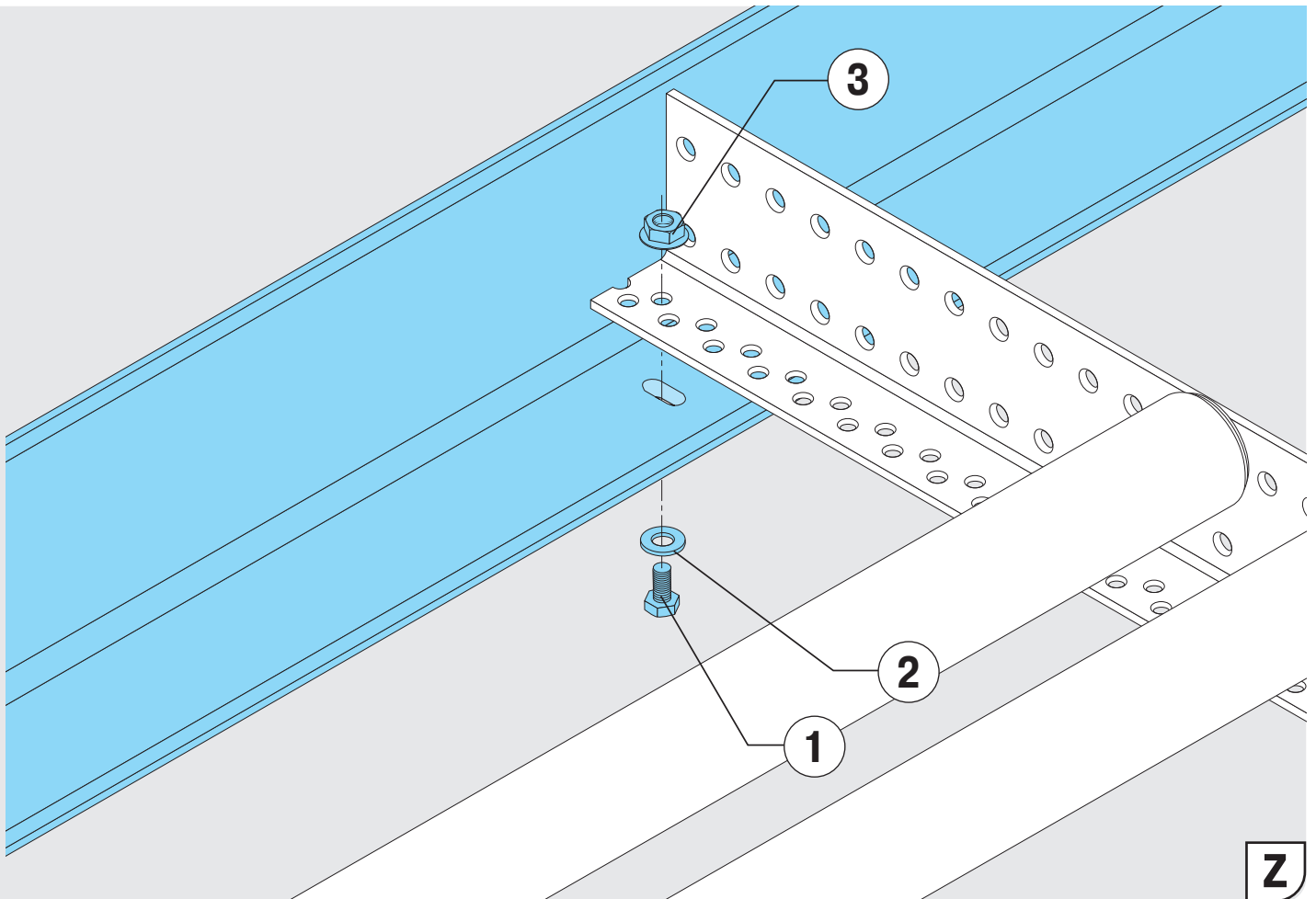

C

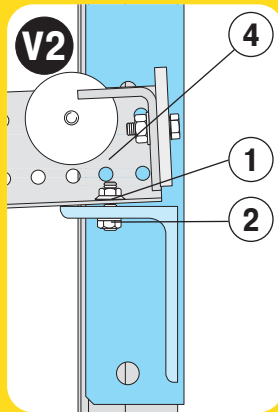
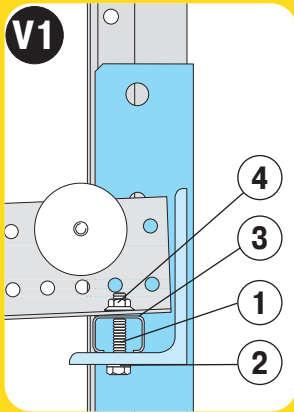
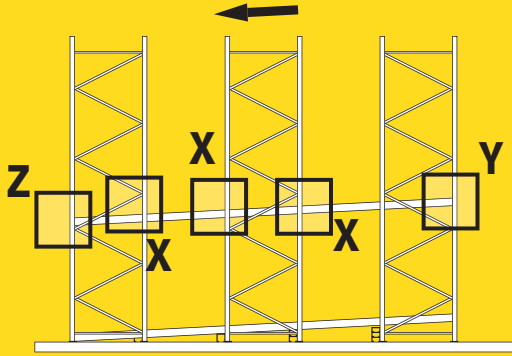

1		M8 x 50 DIN EN ISO 4017	8.8	2x	V1
		M8 x 30 DIN EN ISO 4017	8.8	2x	V2
2		Ø8,4 DIN EN ISO 7089		2x	V1
		Ø8,4 DIN EN ISO 7089		2x	V2
3		25 x 35 x 25 mm		1x	V1
		25 x 35 x 25 mm		0x	V2
4		M8	8	2x	V1
		M8	8	2x	V2
5		ø6,3 x 19N DIN EN ISO 15483		2x	



C

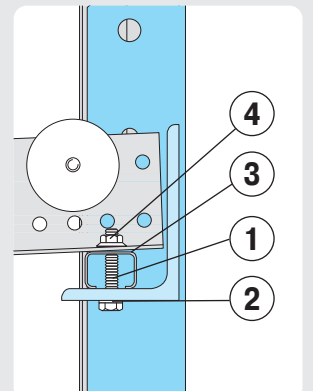
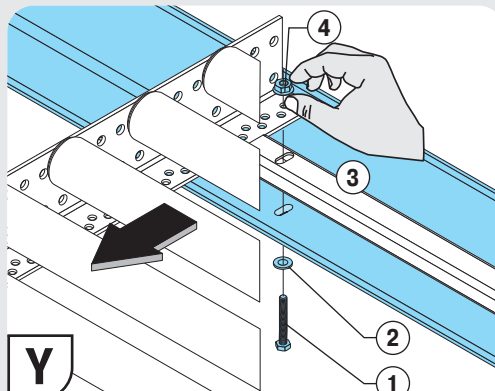
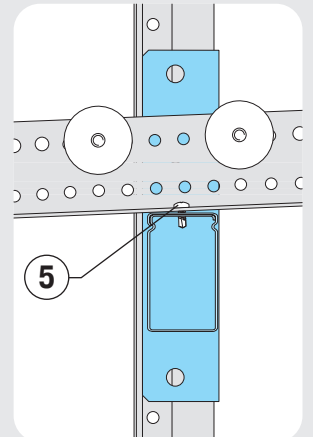
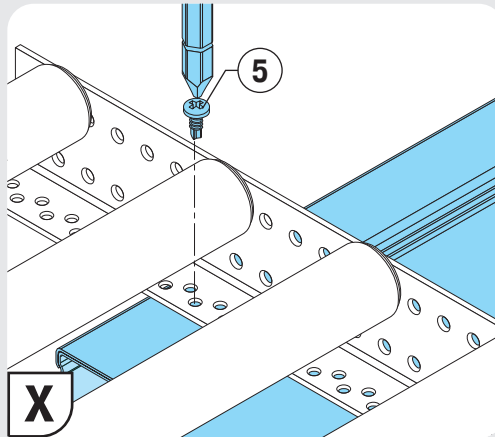
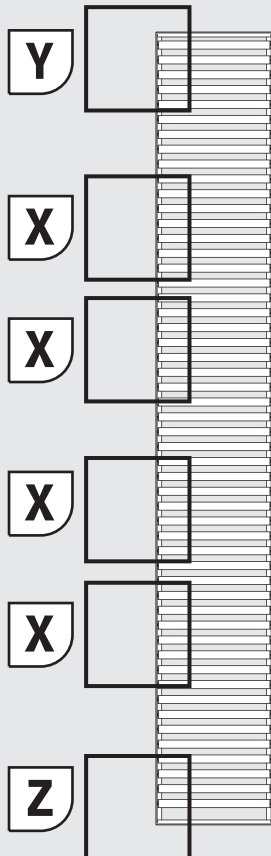

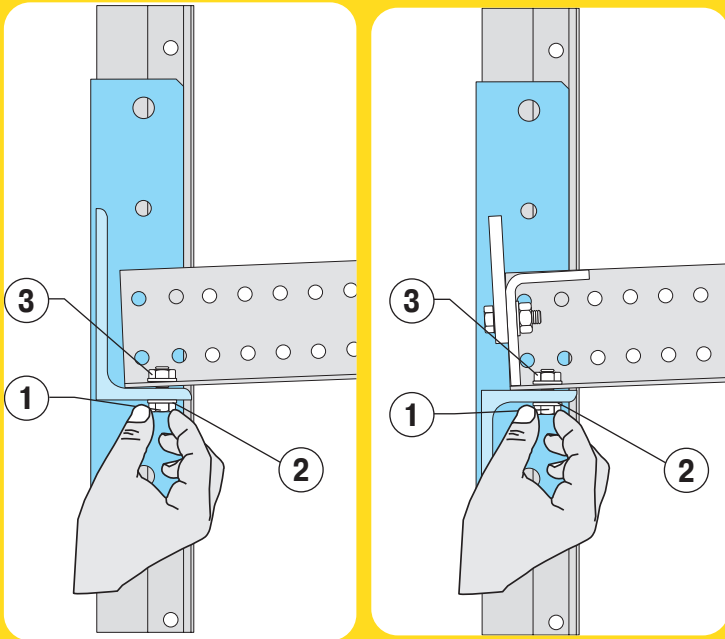
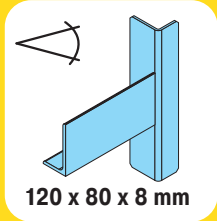

1		M8 x 30 DIN EN ISO 4017	8.8	2x
2		Ø8,4 DIN EN ISO 7089		2x
3		M8	8	2x

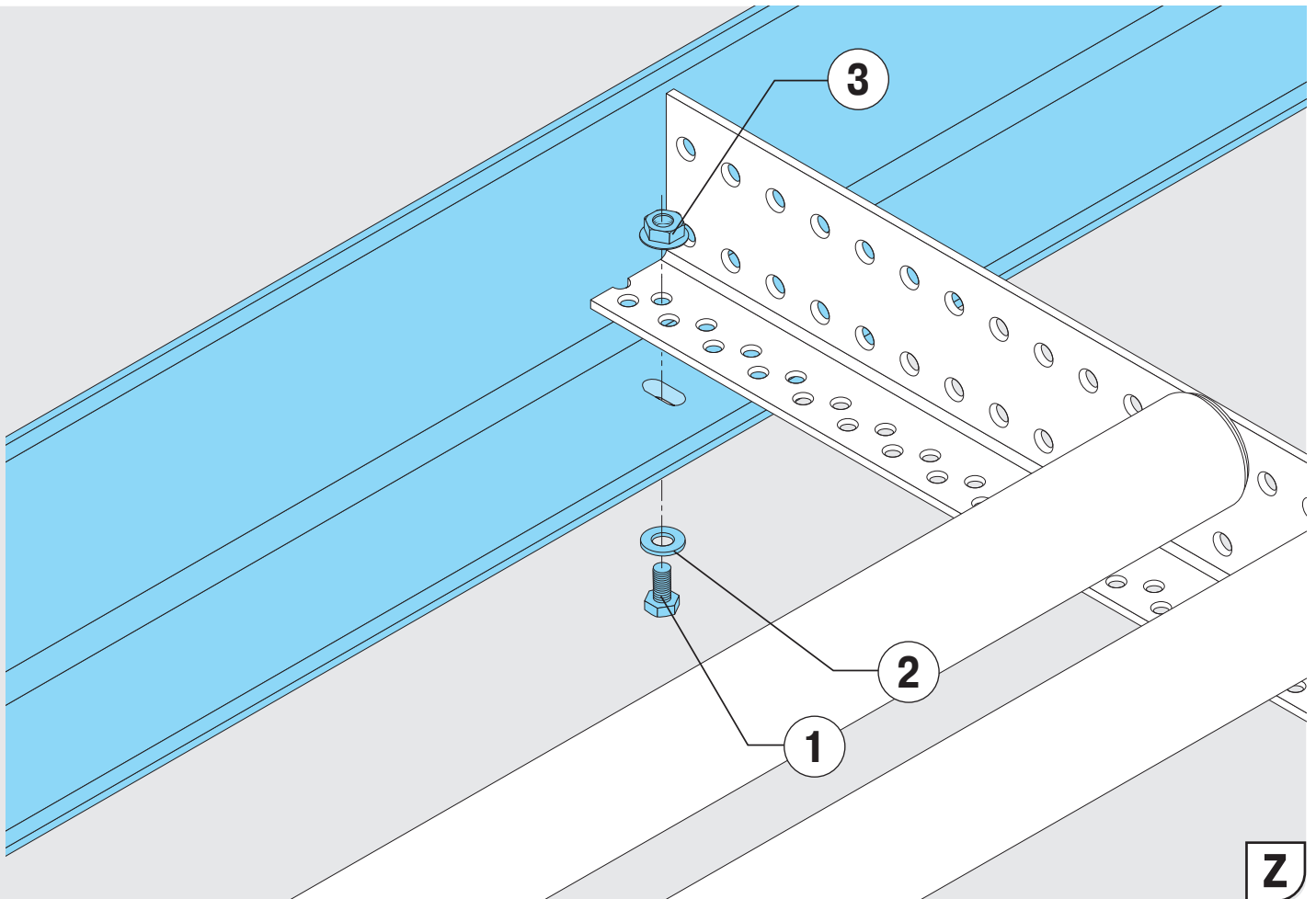

PROFLOW



D

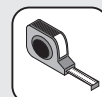
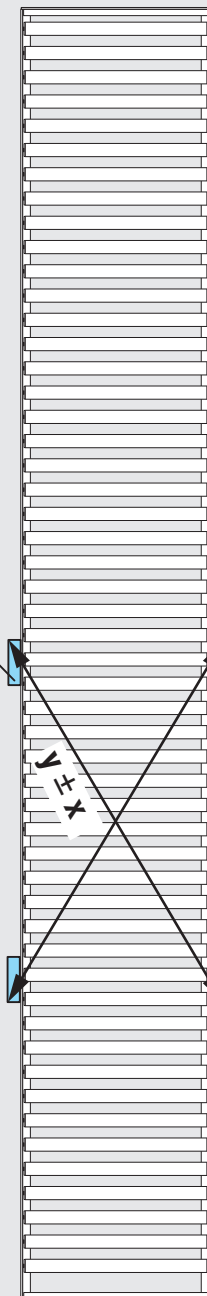
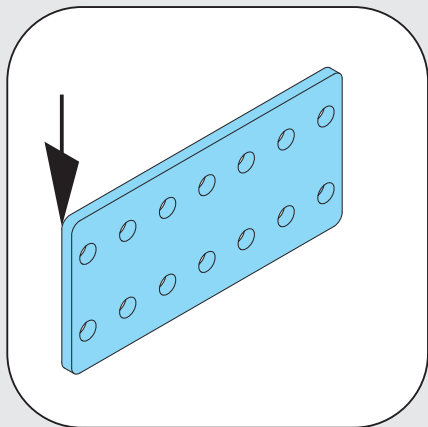
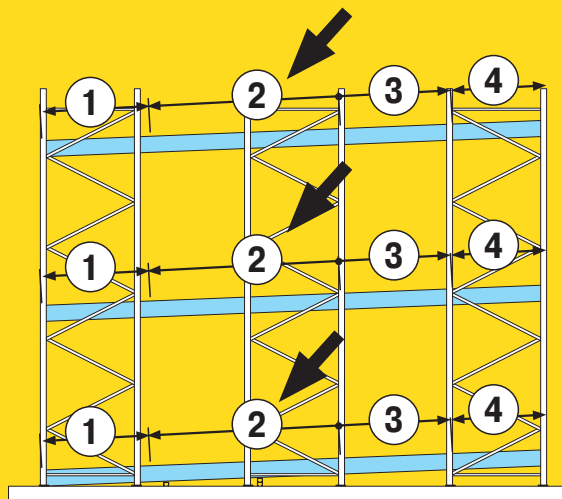

$$x = y \pm 1$$

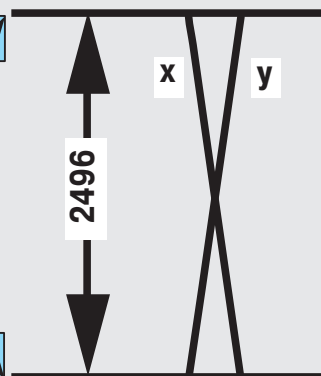

PROFLOW





E

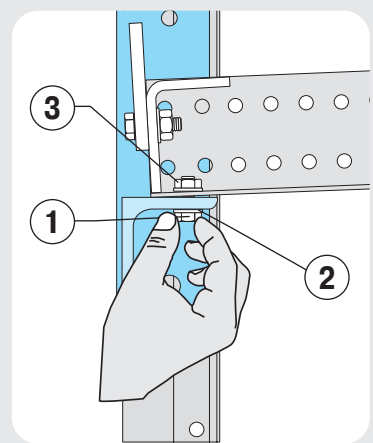
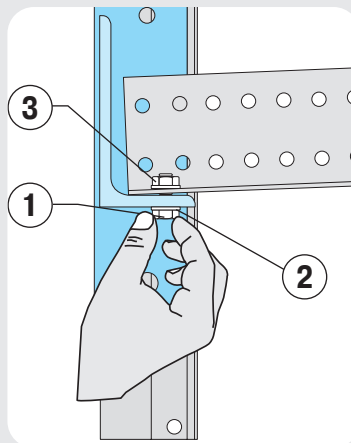
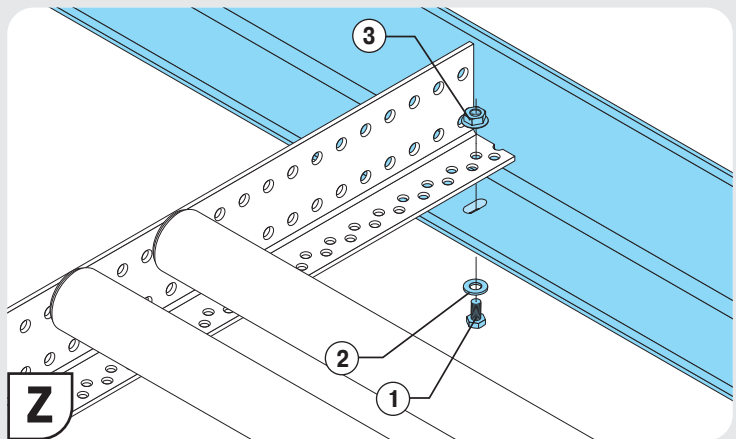
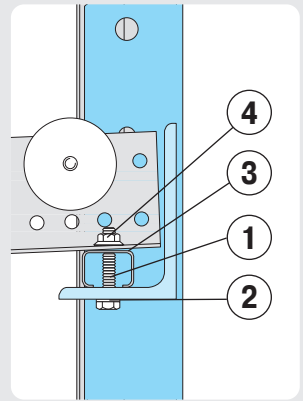
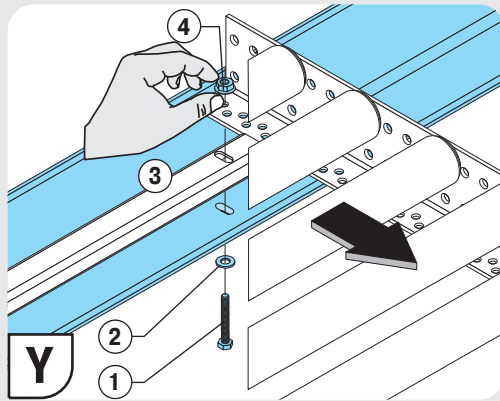
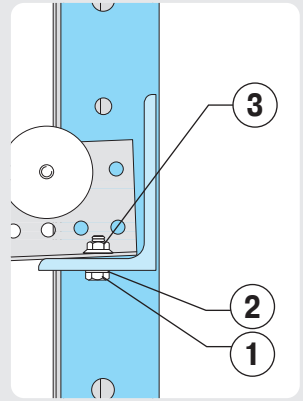
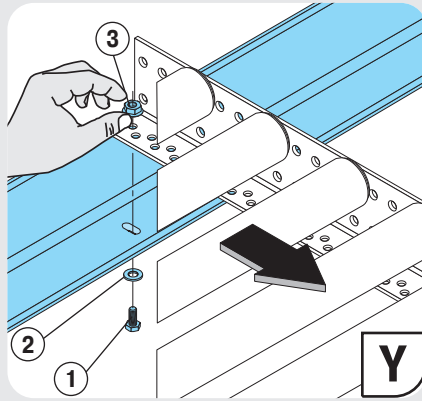
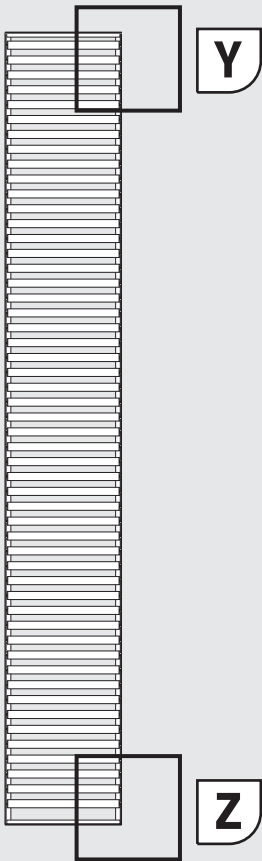

PROFLOW



F

PROFLOW

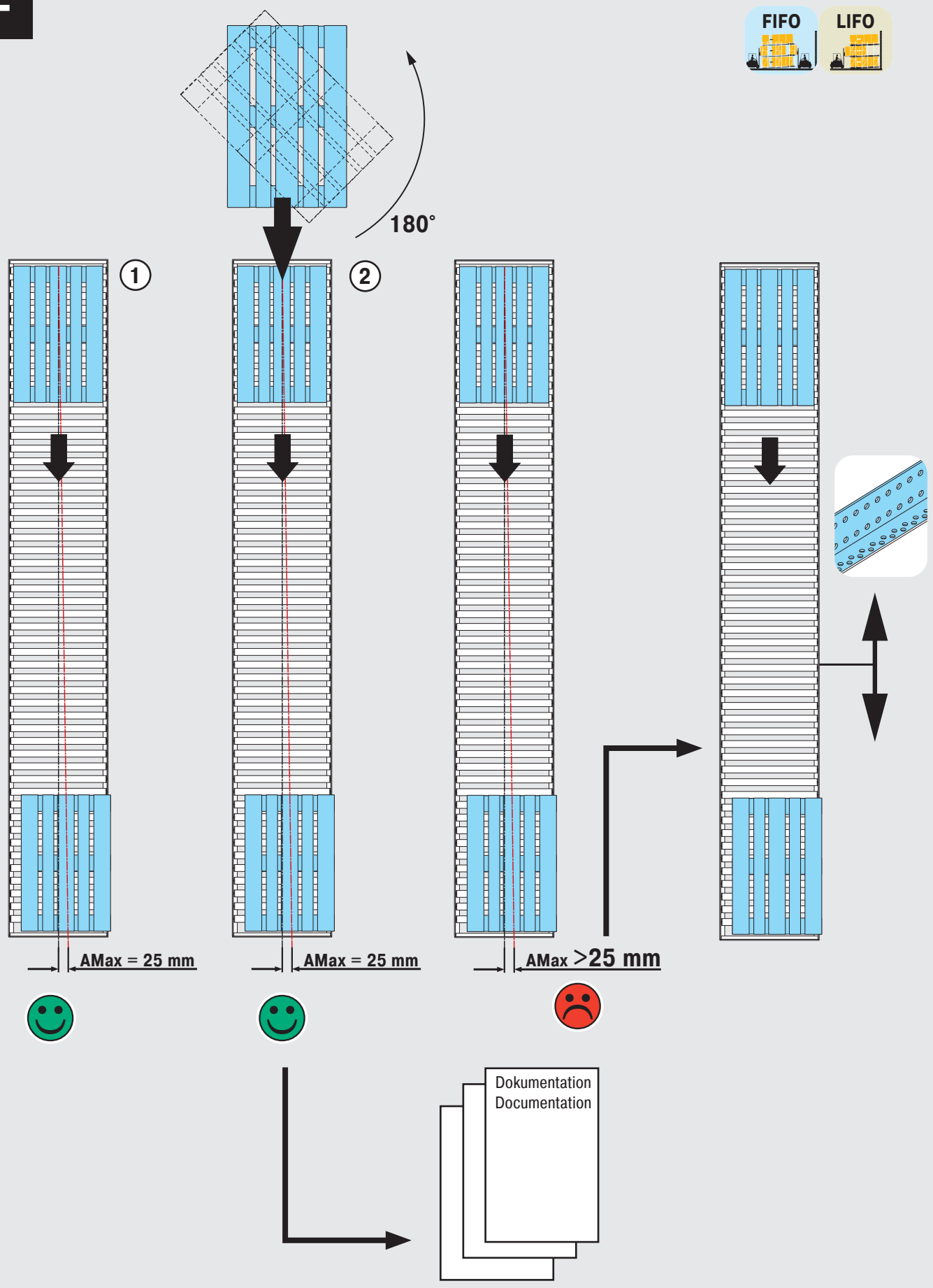

G

FIFO

LIFO

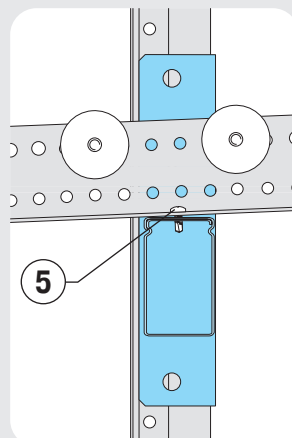
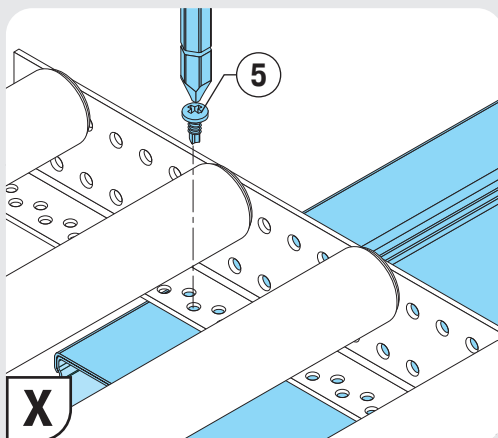
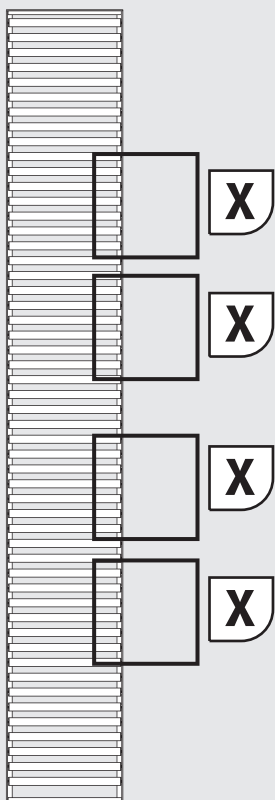

PROFLOW



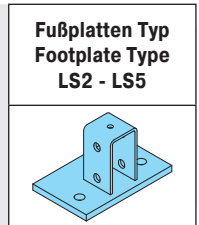
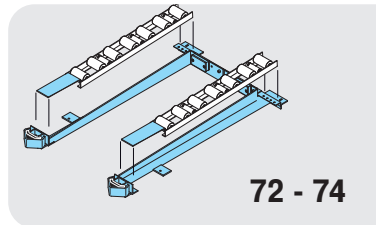
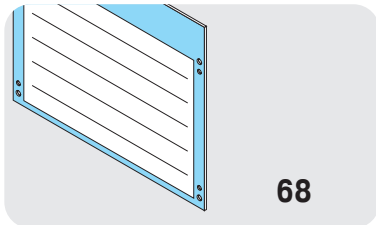
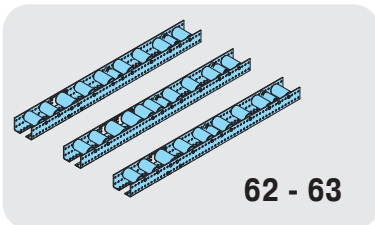
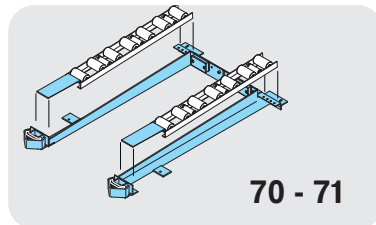
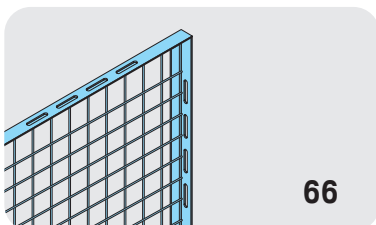
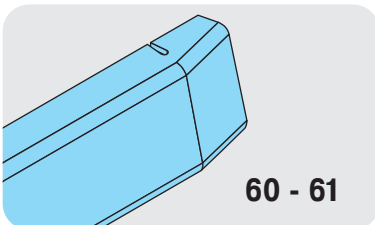
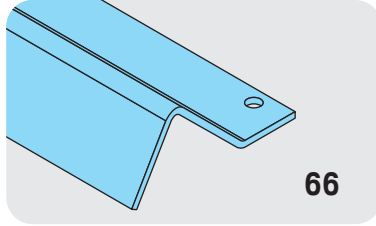
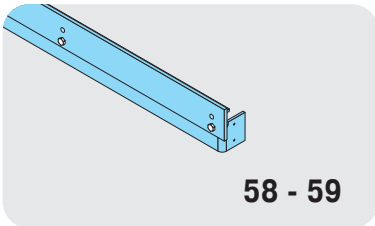
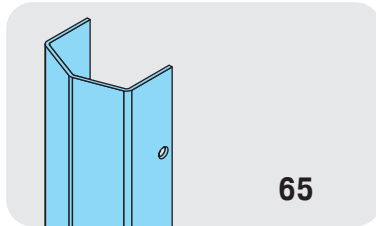
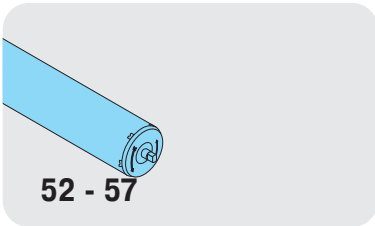
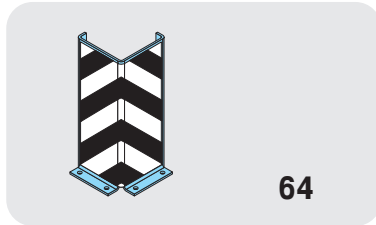
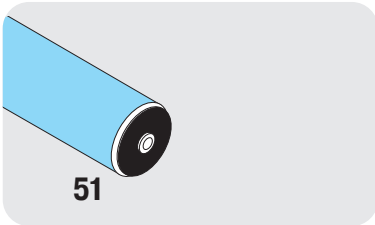
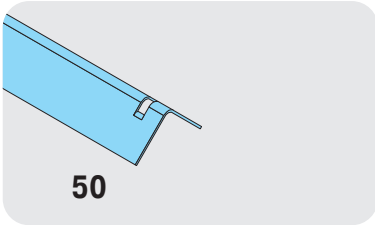
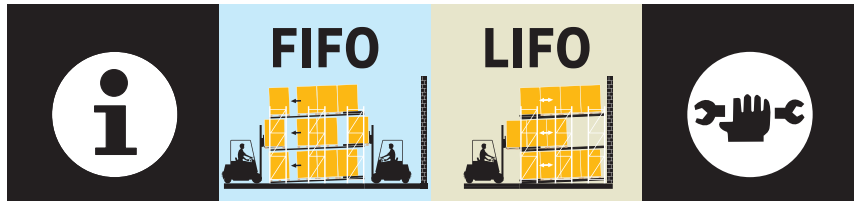

FIFO

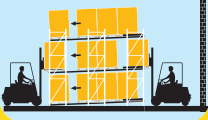

LIFO

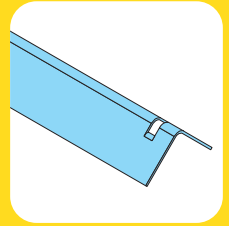

PROFLOW

i BITO

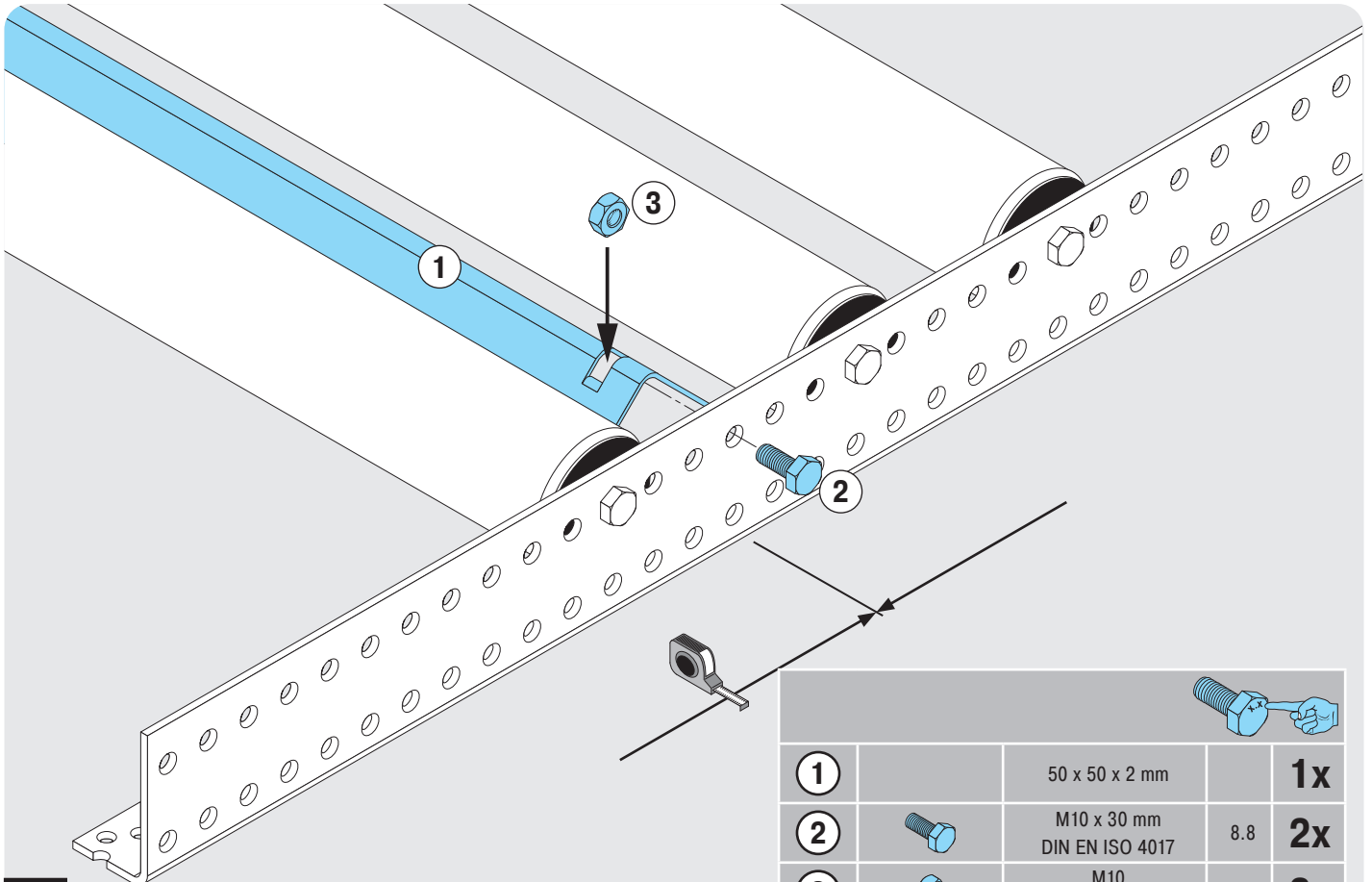
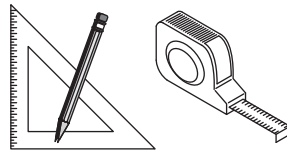
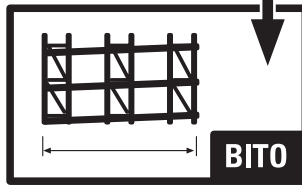

1		50 x 50 x 2 mm		1x
2		M10 x 30 mm DIN EN ISO 4017	8.8	2x
3		M10 DIN EN ISO 4032	8	2x



FIFO

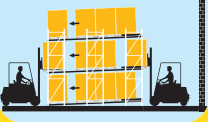

LIFO

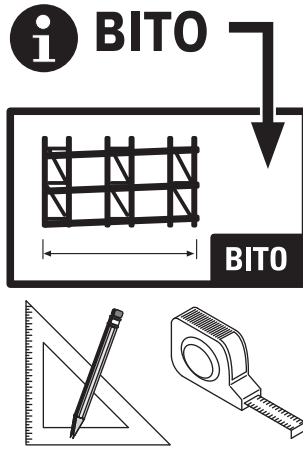
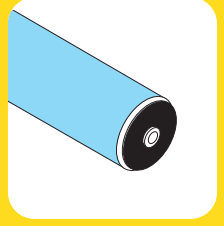

PROFLOW

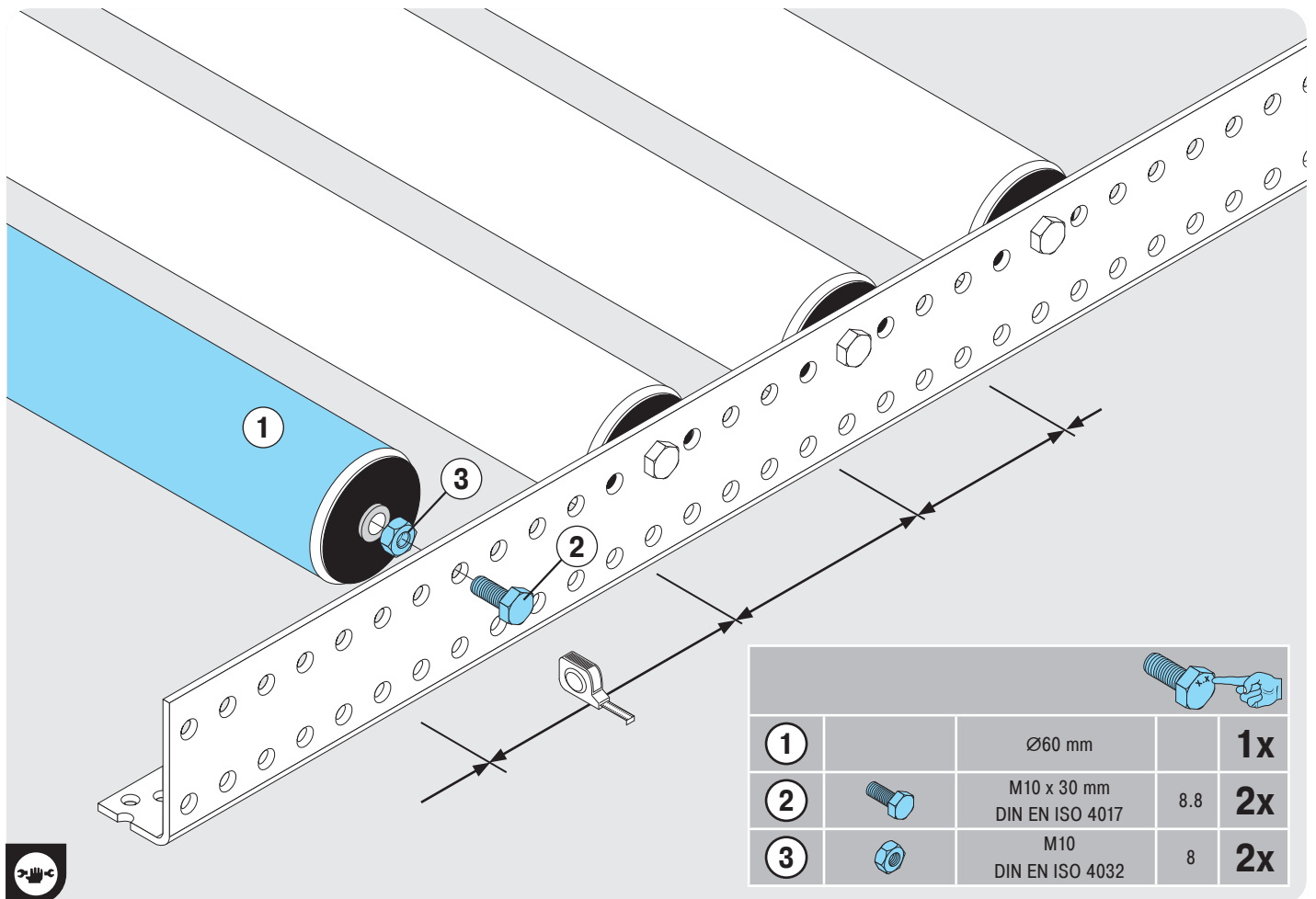

1		Ø60 mm		1x
2		M10 x 30 mm DIN EN ISO 4017	8.8	2x
3		M10 DIN EN ISO 4032	8	2x





FIFO

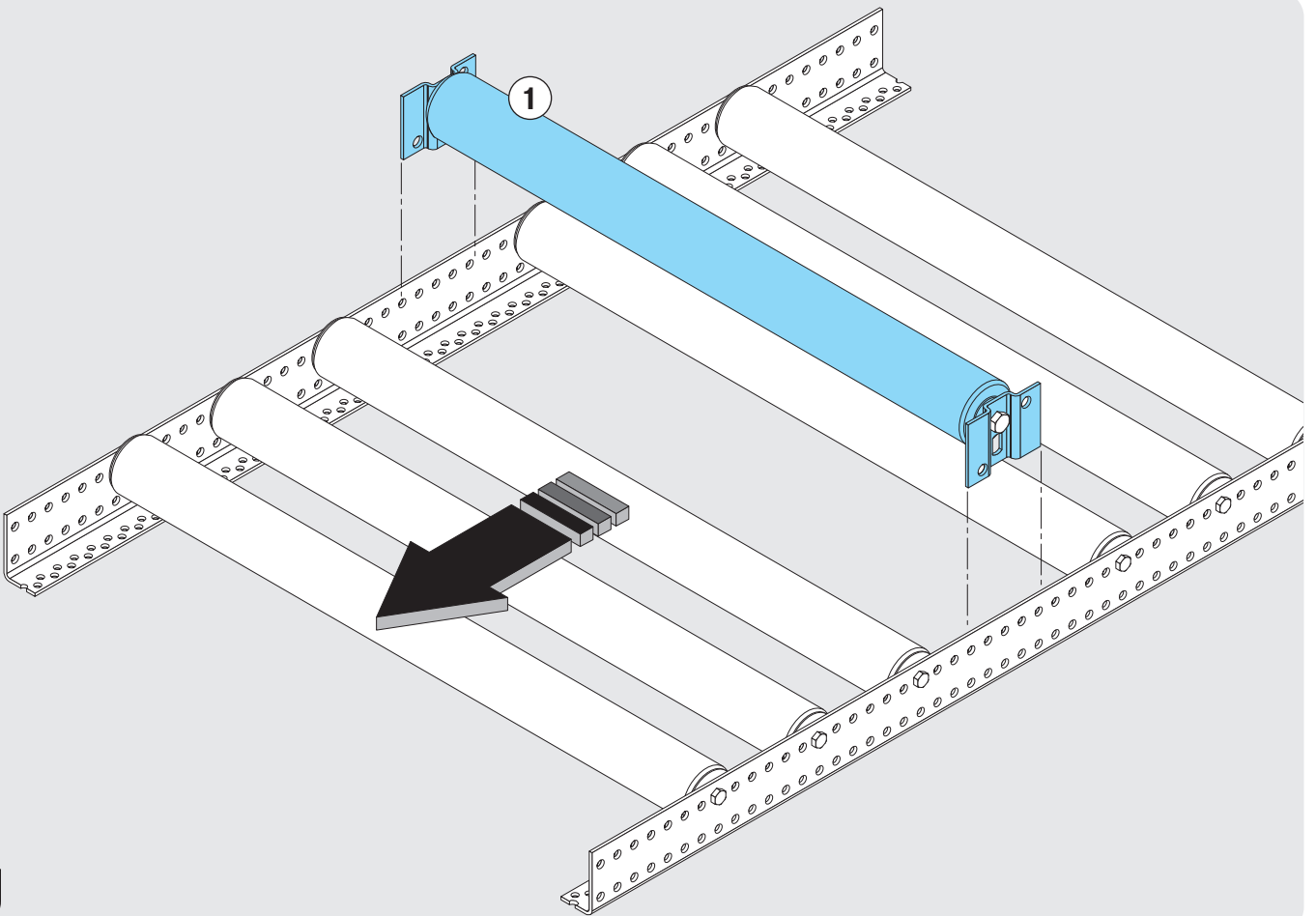
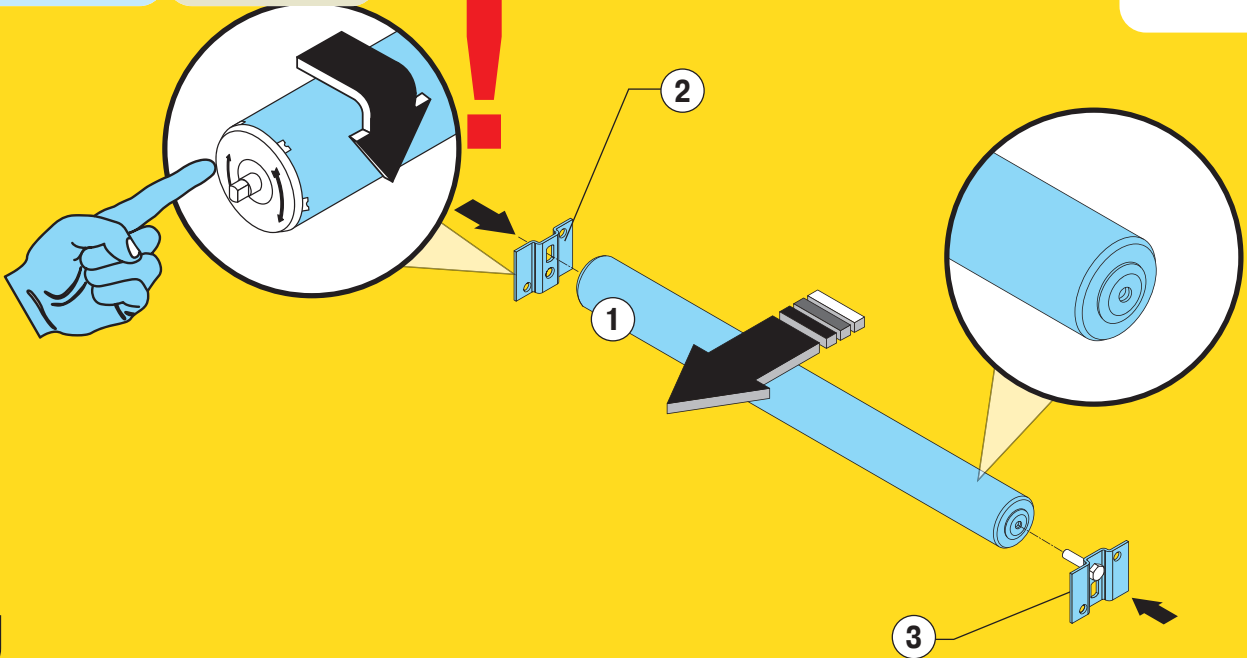
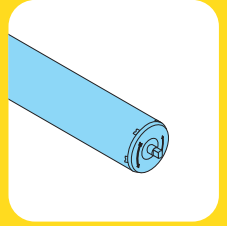

LIFO

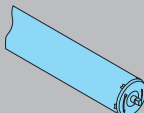
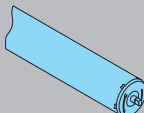
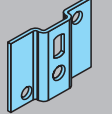
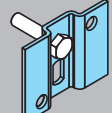

		Ø80 mm		1x
1		Ø80 mm		1x
2				1x
3				1x
4		M10 x 20 mm DIN EN ISO 4017	8.8	4x
5		M10 DIN EN ISO 4032	8	4x

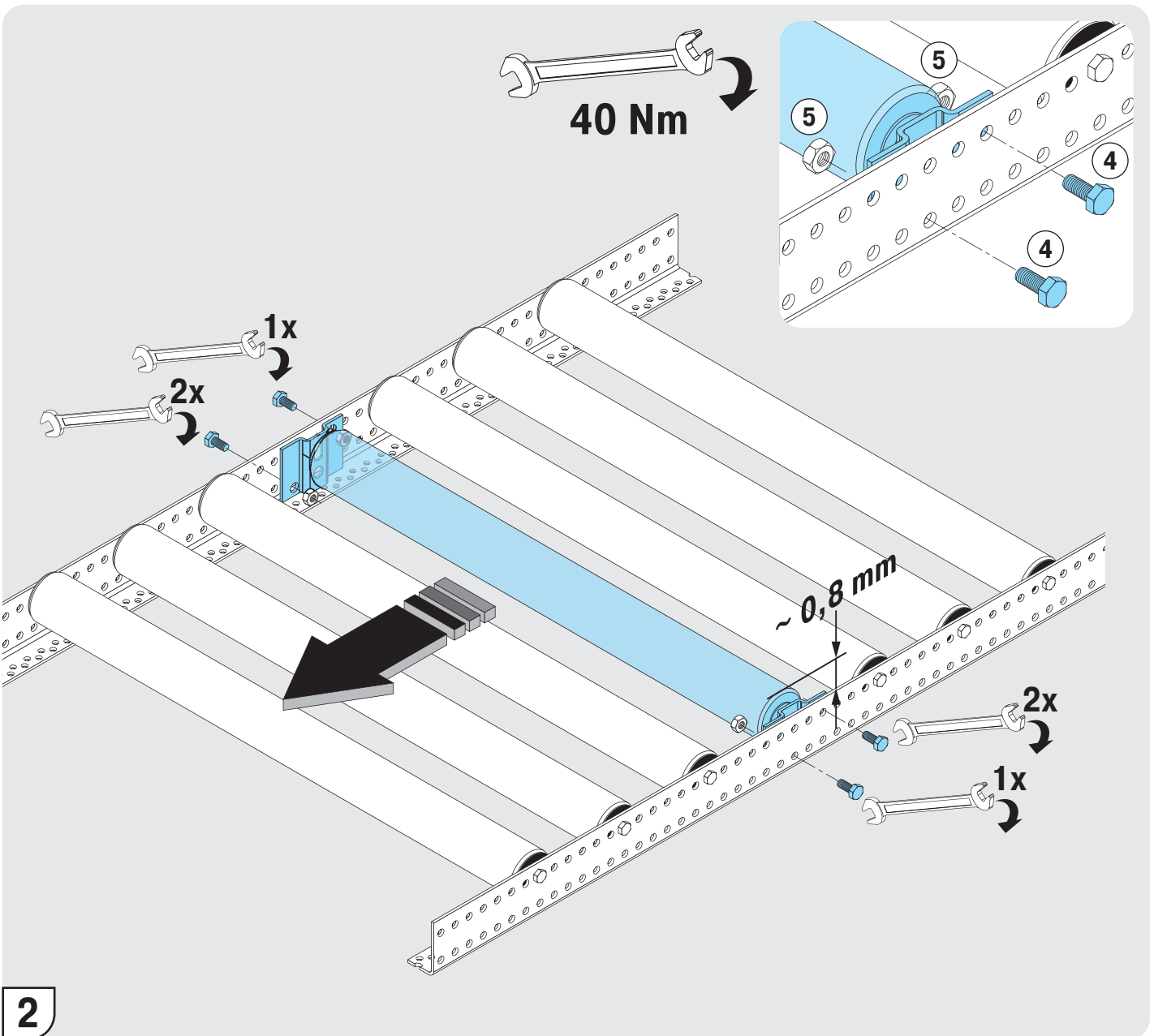

FIFO

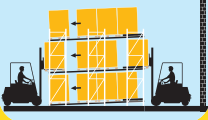

LIFO

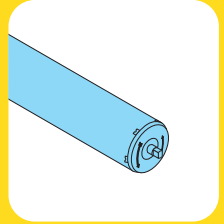

Freilauf-Halter
One way brake roller

Freilauf-Halter
One way brake roller

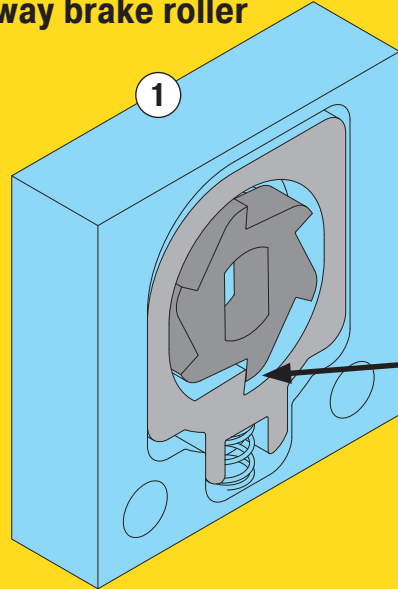
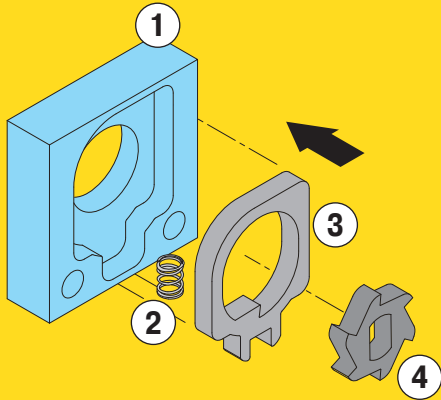

PROFLOW

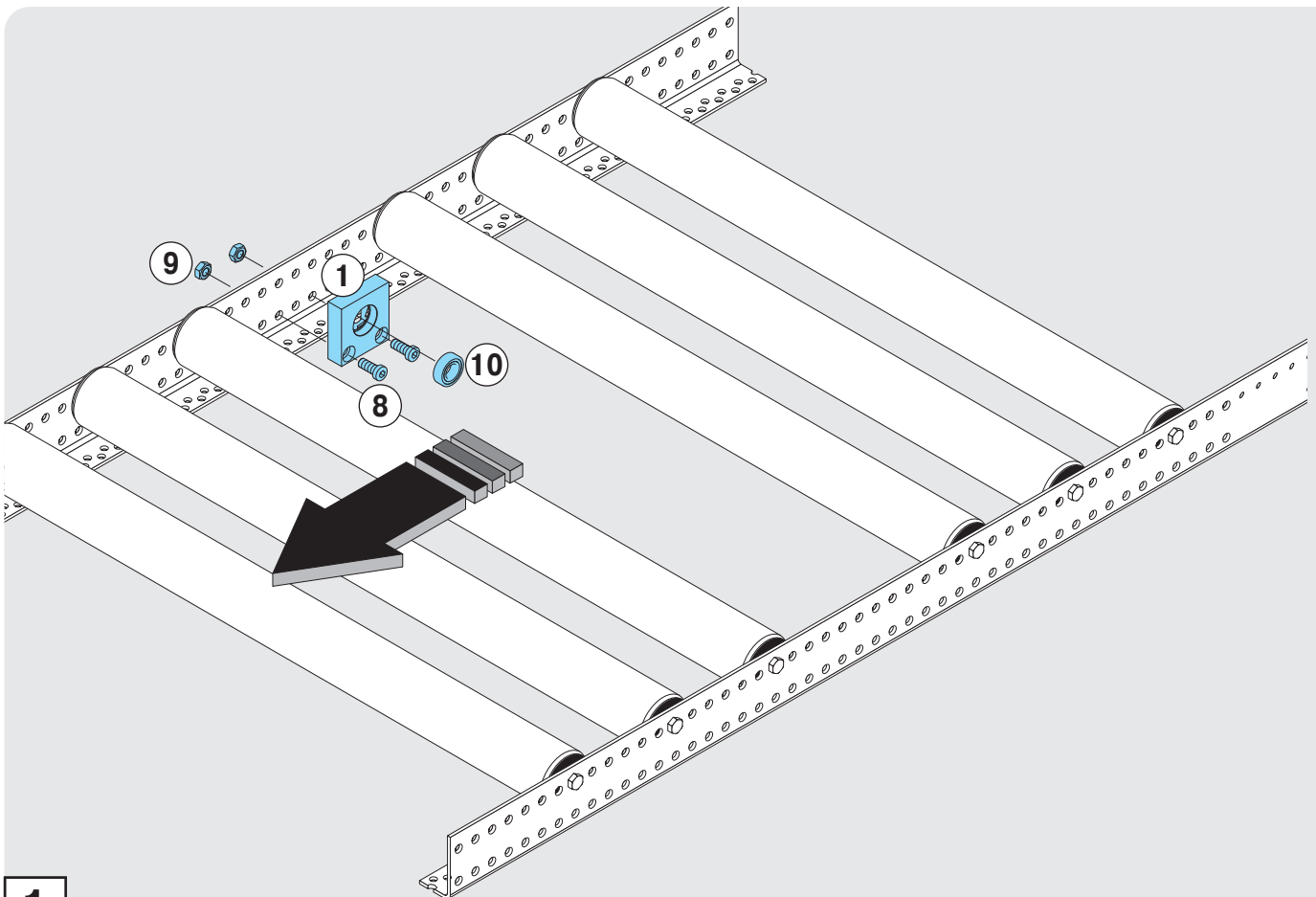

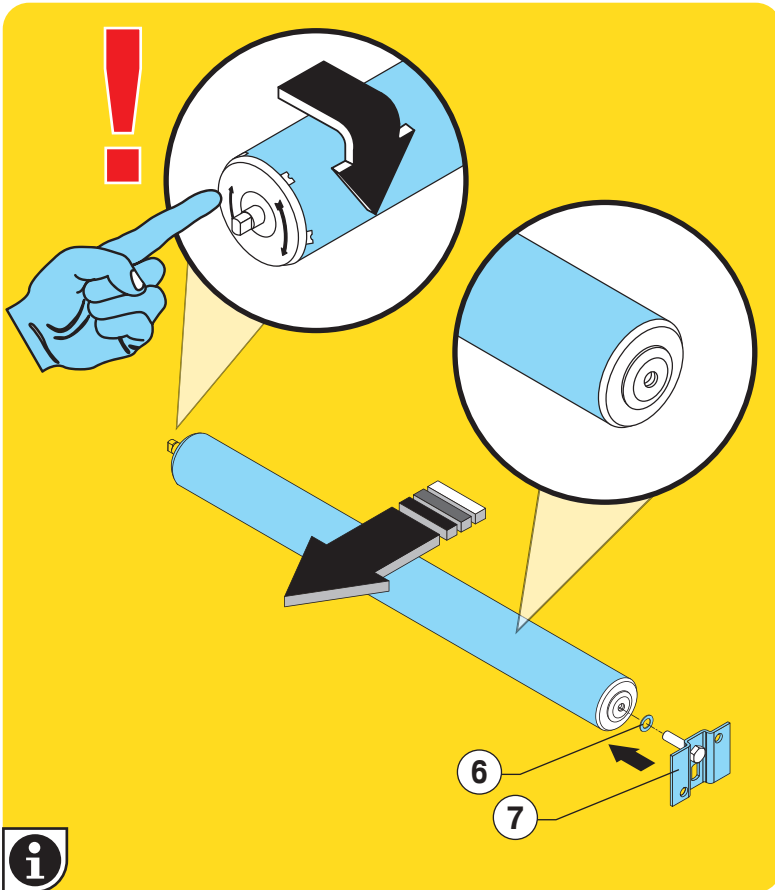

1				1x
2				1x
3				1x
4				1x
5		Ø80 mm		1x
6		M10 ISO 7089		1x
7				1x
8		M10 x 20 mm DIN EN ISO 4017	8.8	4x
9		M10 DIN EN ISO 4032	8	4x
10				1x

PROFLOW

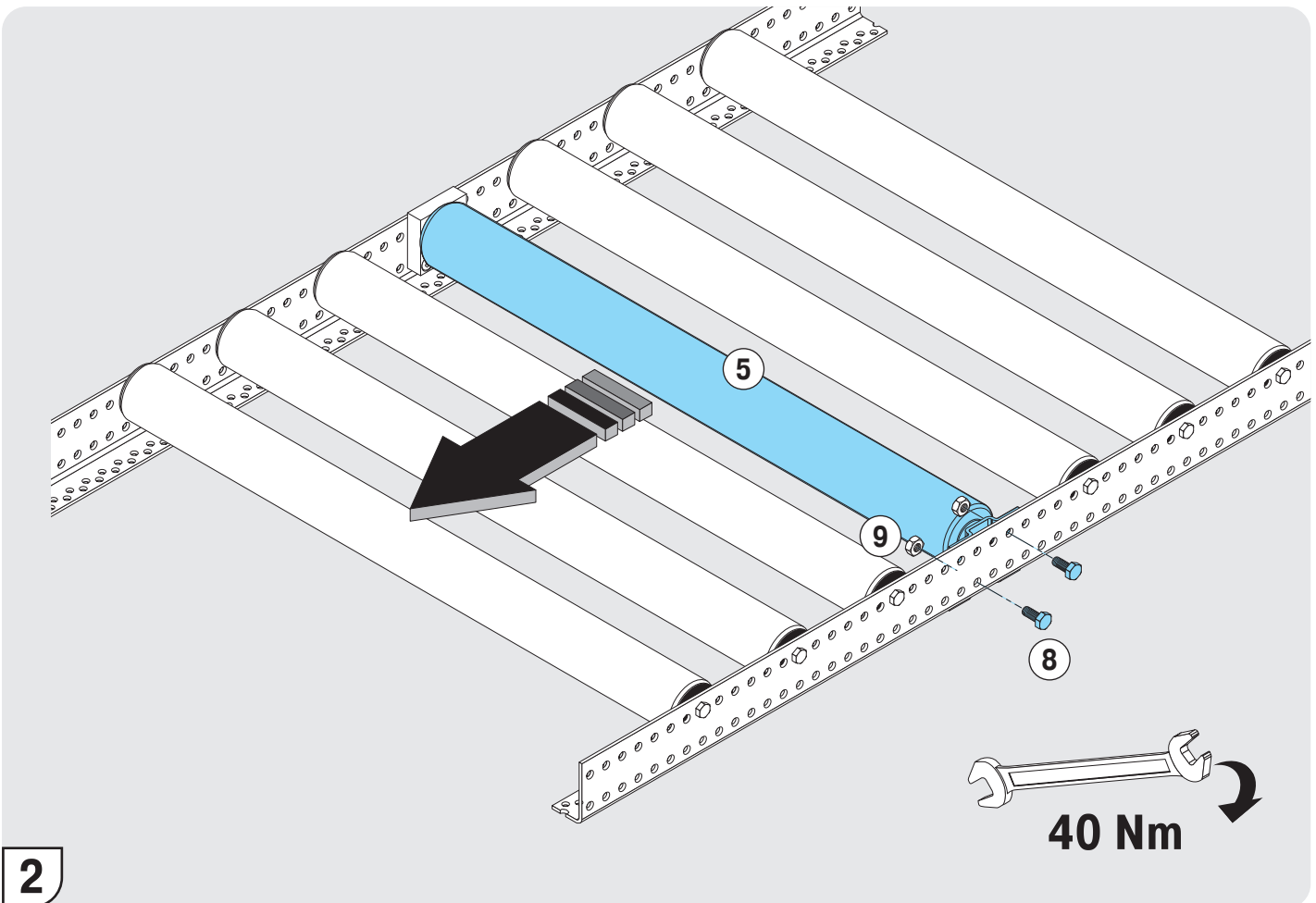



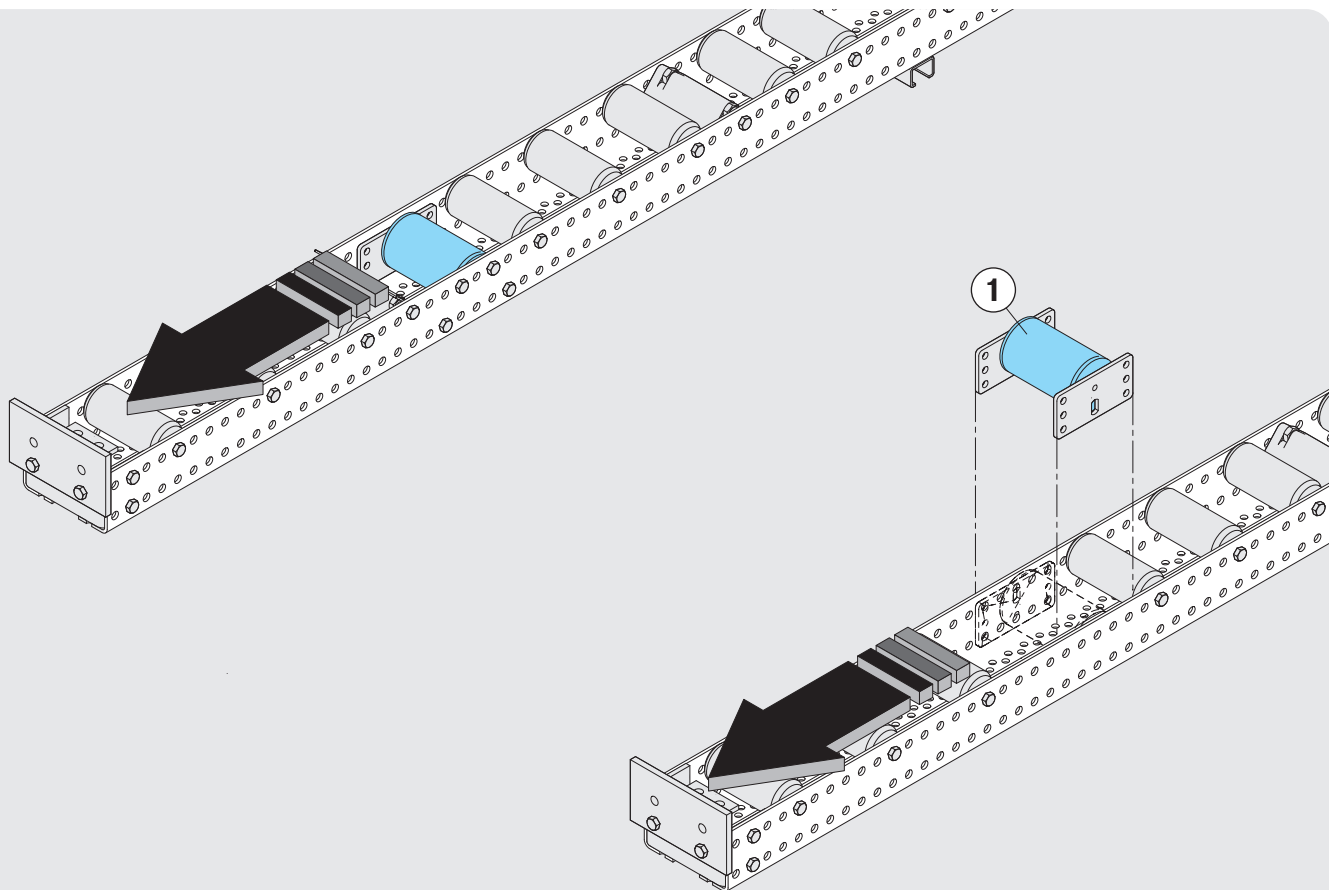
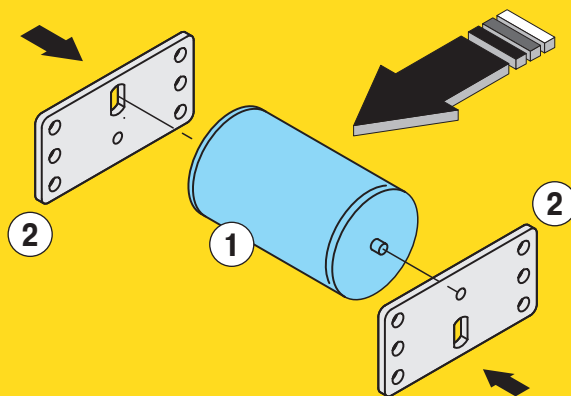
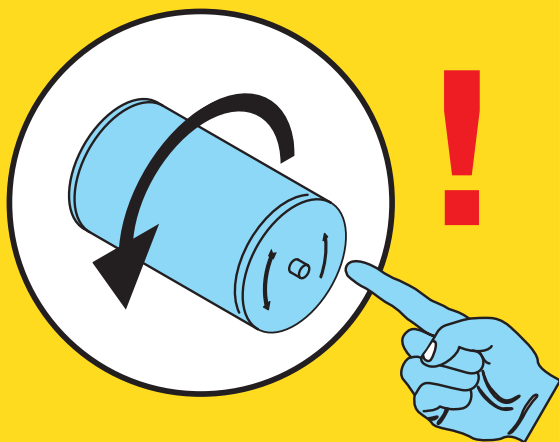

2

40 Nm

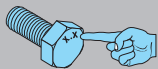
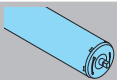
BTR 124



				
1		Ø80 mm		1x
2		BTR T72		2x
3		M10 x 20 mm DIN EN ISO 4017	8.8	4x
4		M10 DIN EN ISO 4032	8	4x

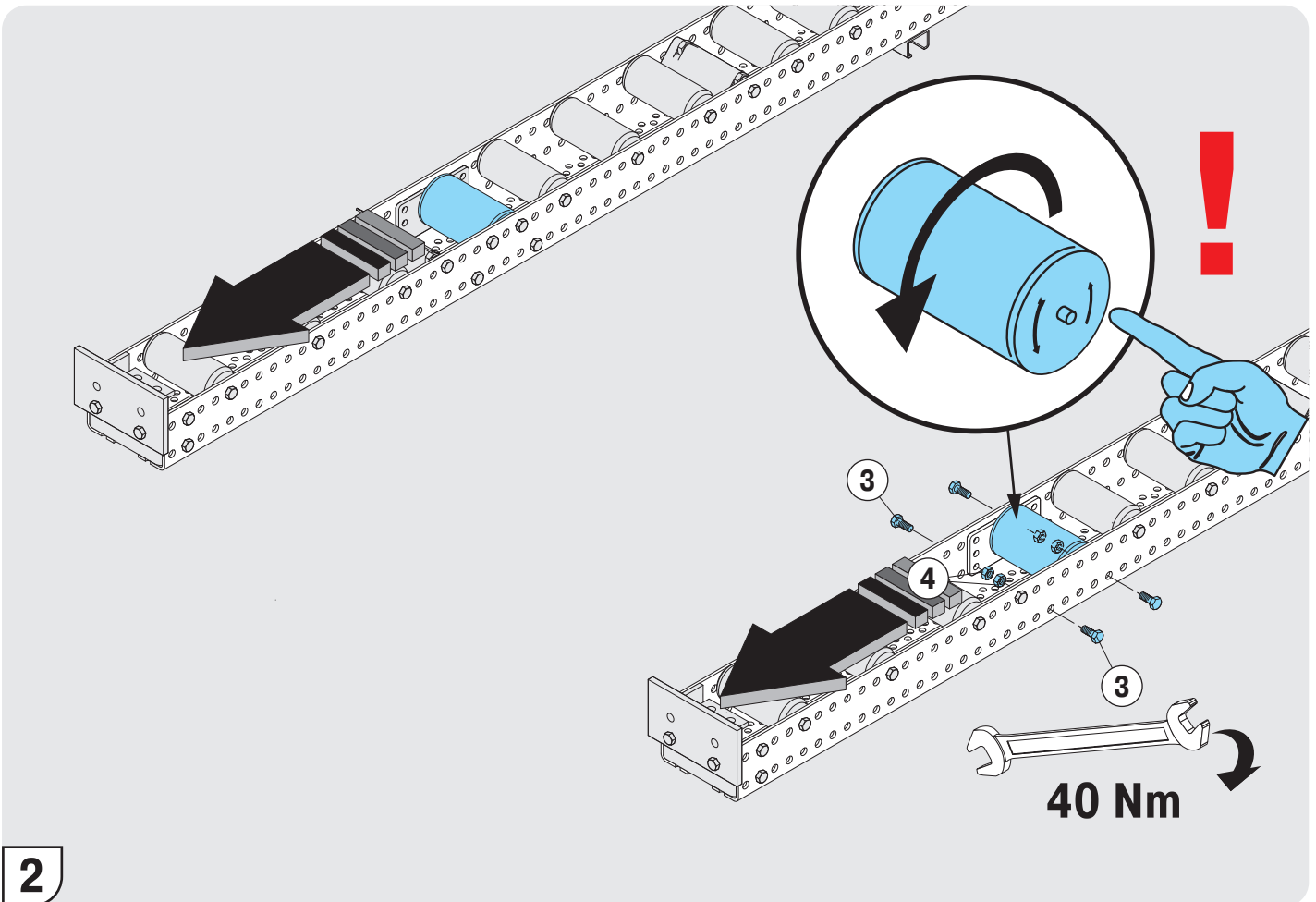

2

FIFO

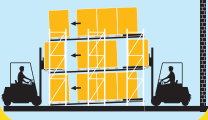



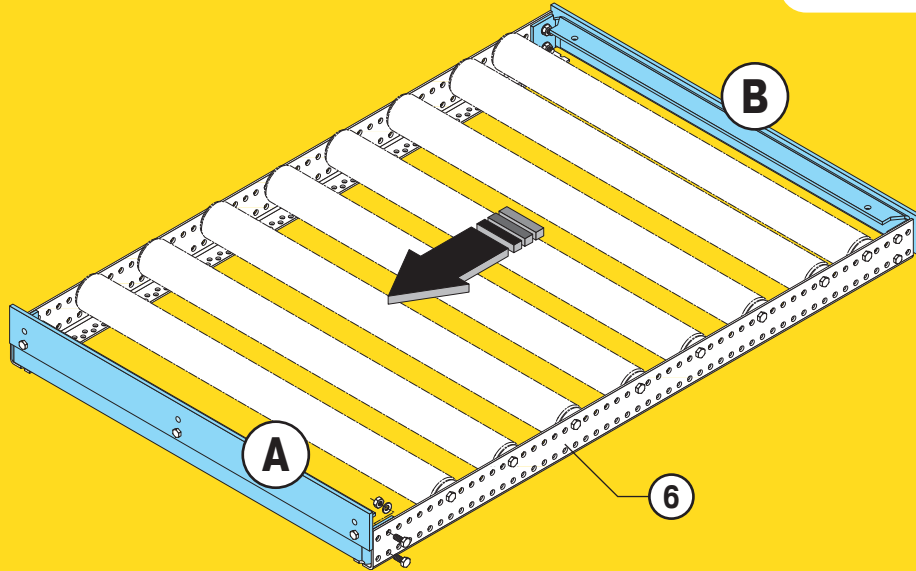
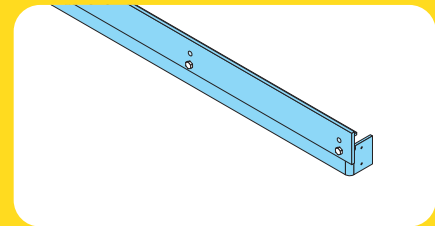

LIFO

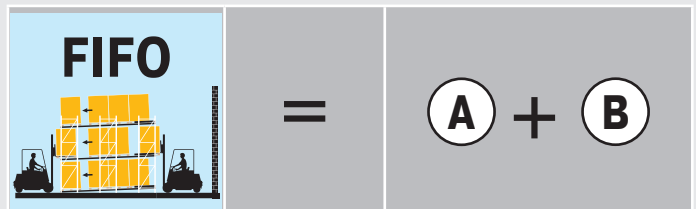
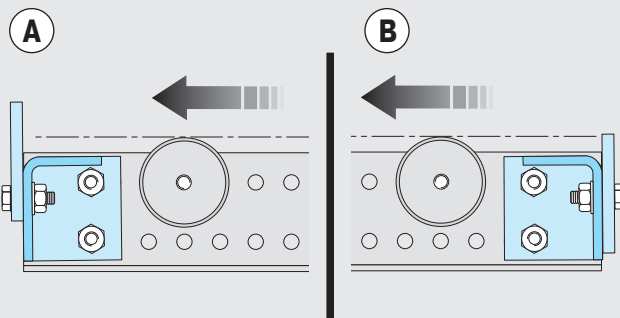
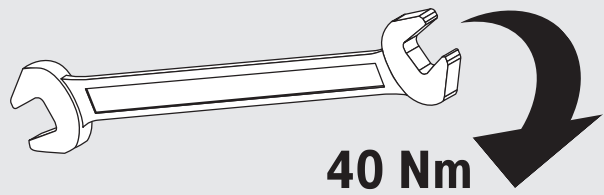
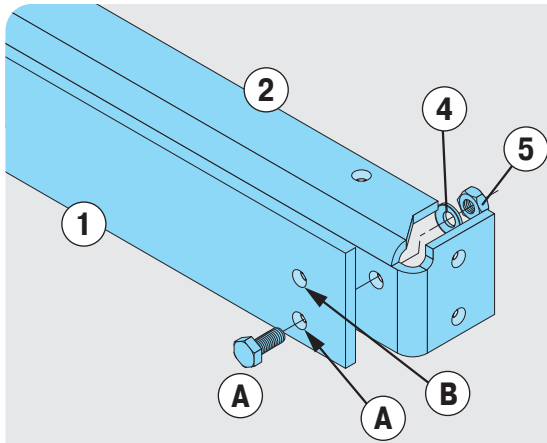

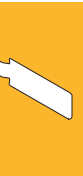
PROFLOW

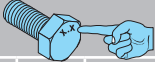



				
①				1x
②				1x
③		M10 x 30 mm DIN EN ISO 4017	8.8	7x
④		Ø10,3 mm		7x
⑤		M10 DIN EN ISO 4032	8	7x
⑥				2x

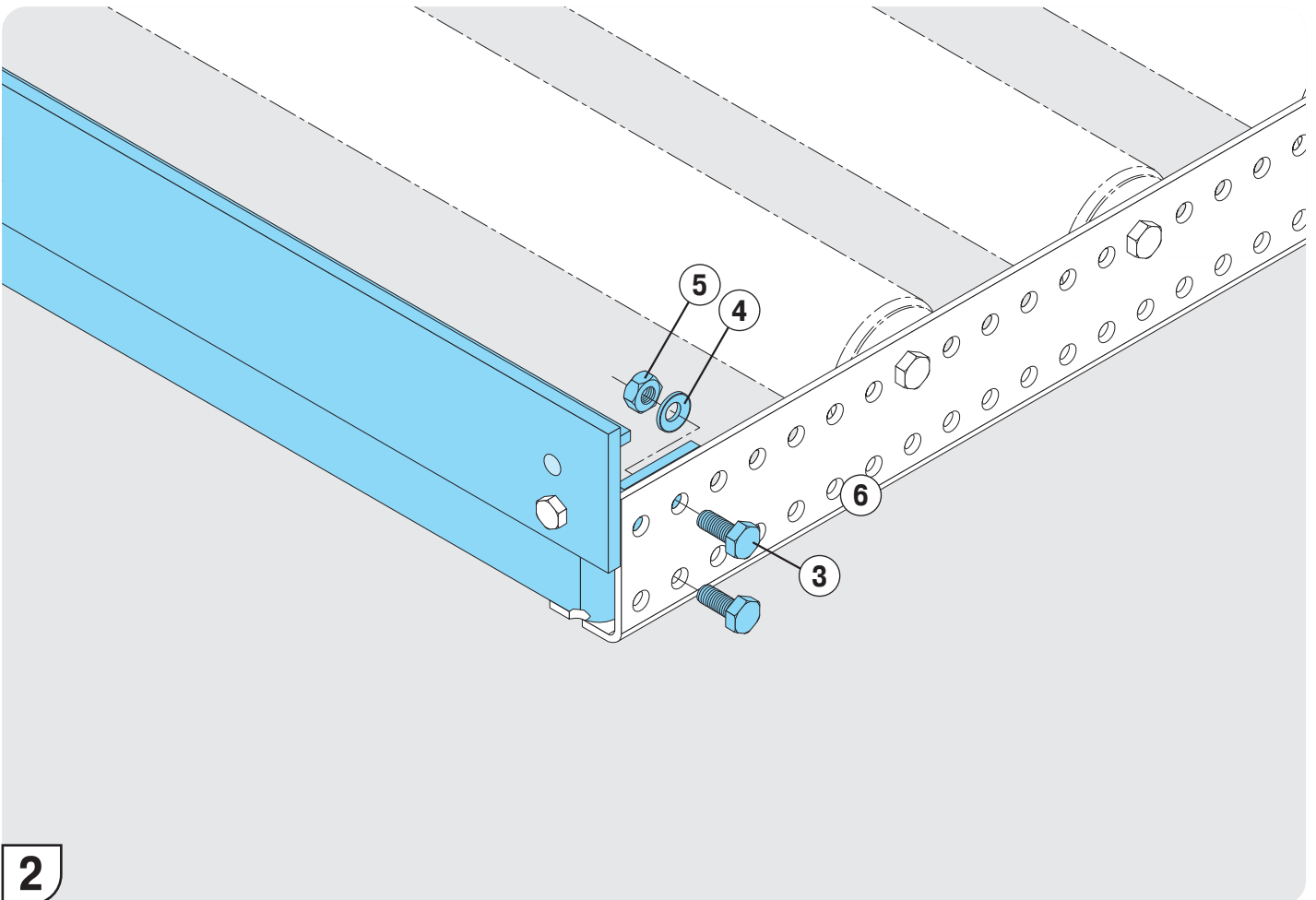

2



FIFO



PROFLOW

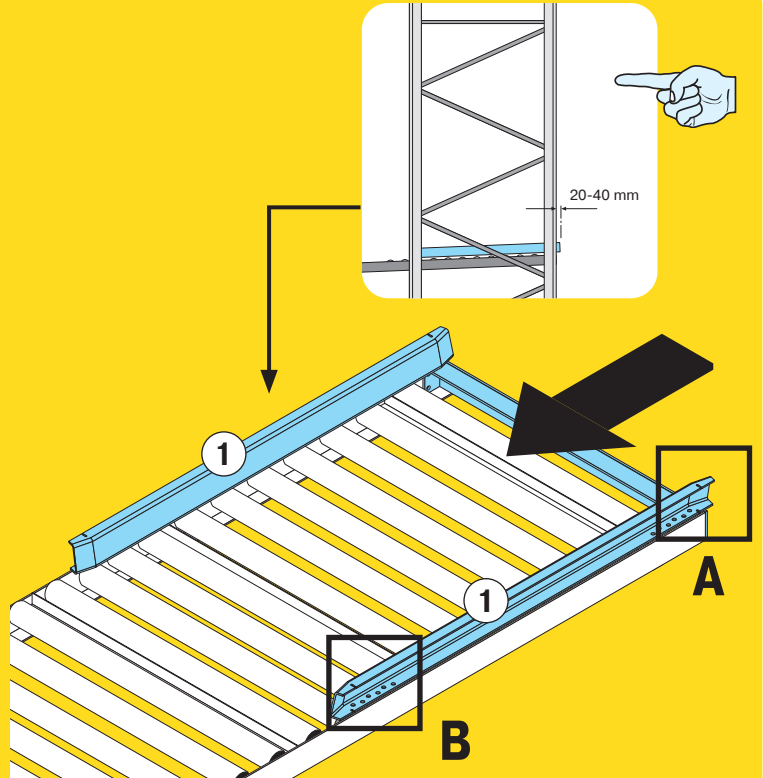
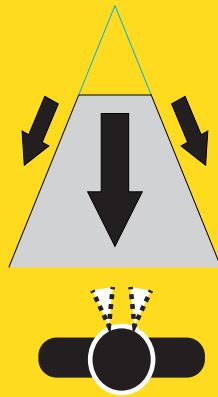
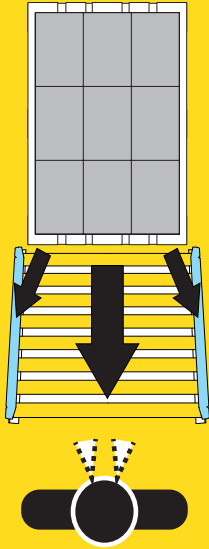

1					2x
2					4x
3		M8 x 20 mm DIN EN ISO 4017	8.8		4x
4		Ø8,4			4x
5		M8 DIN EN ISO 4032	8		4x
6		M10 x 30 mm DIN EN ISO 4017	8.8		8x
7		M10 DIN EN ISO 4032	8		8x

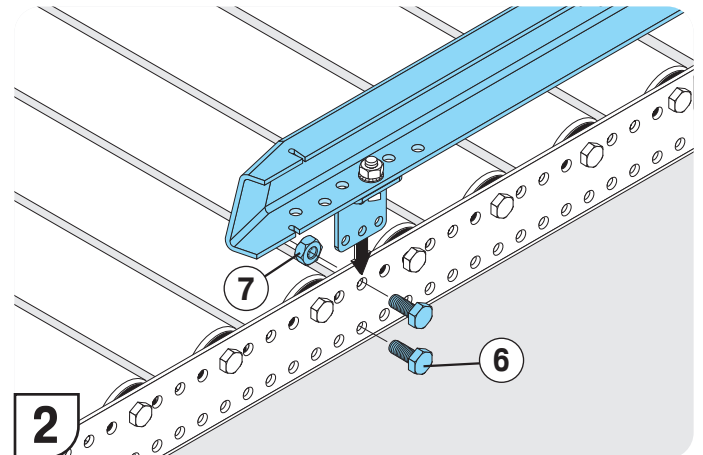
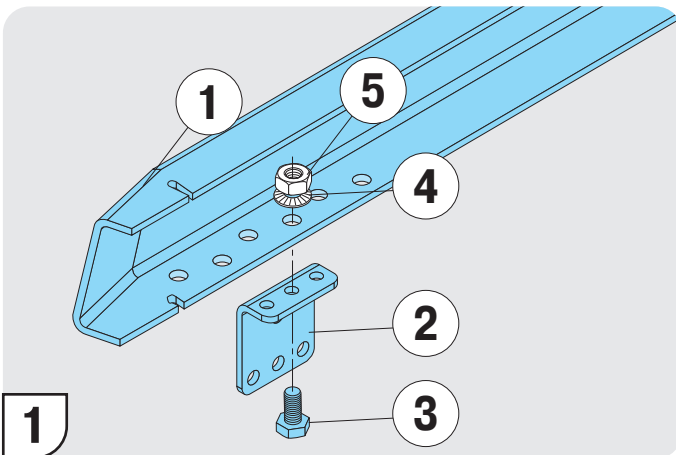

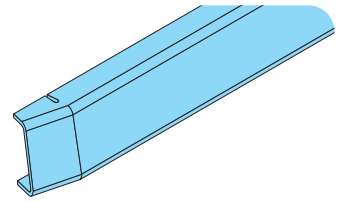

A

EL	LW
872 mm	810 mm
1072 mm	1010 mm
1272 mm	1210 mm

B

EL	LW
872 mm	822 mm
1072 mm	1022 mm
1272 mm	1222 mm

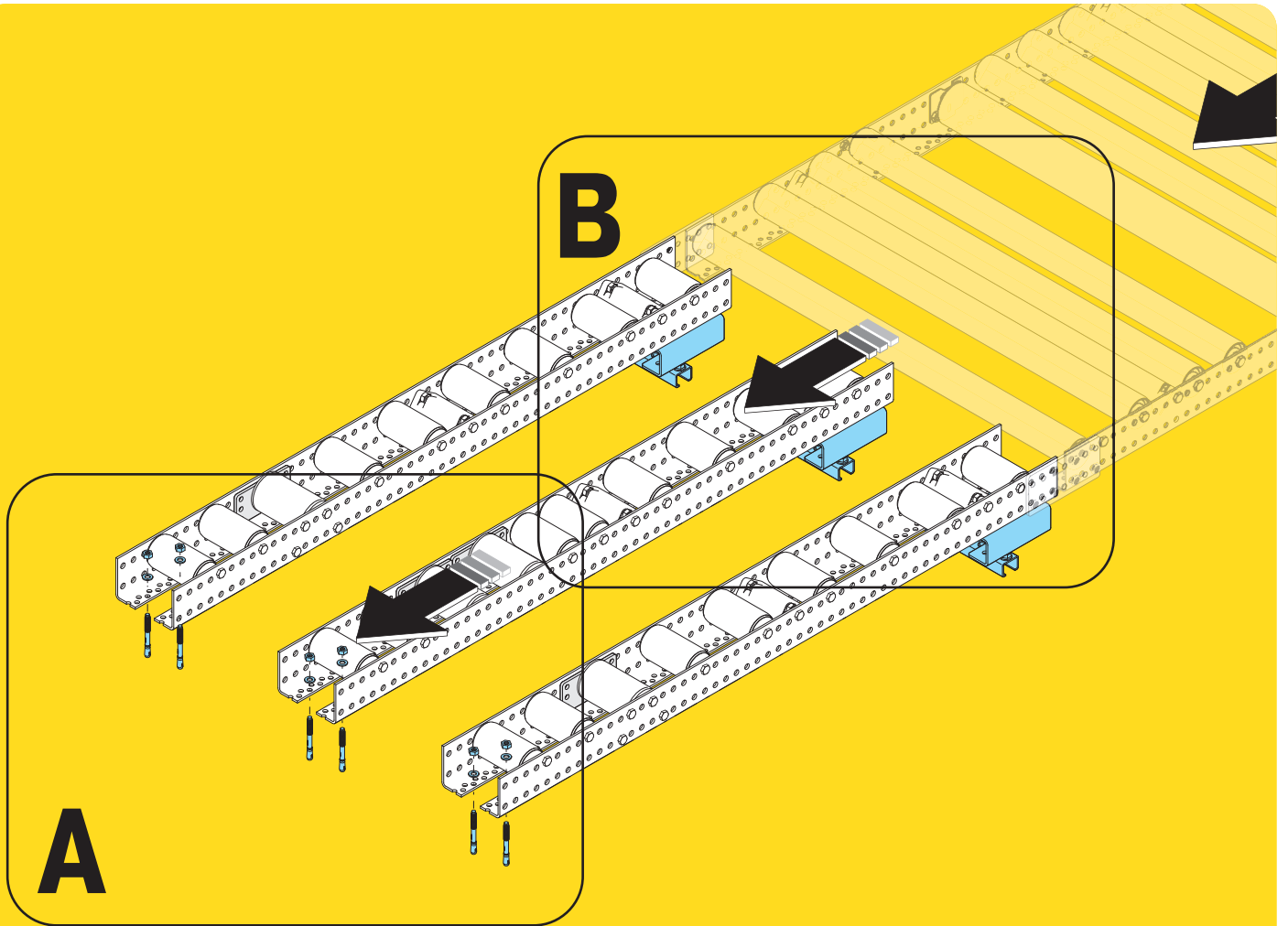

Rollenbahnsegmente, 3-geteilte Ausführung
Roller conveyor segment, three-track option



1	36981		116 x 2,5 mm		3	8	03408		M10-20
2	38366		50 x 45 x 4 x 140 mm		6				
3	03366		ISO 4017 M10 x 65	8.8	6				
4	03345		ISO 4017 M8 x 20	8.8	12				
5	03458		ISO 7093-1		18				
6	03404		EN 1661 M8	8	12	A			
7	03388		ISO 4032 M10	8	18	B			
8	03408		M10-20		9	C			

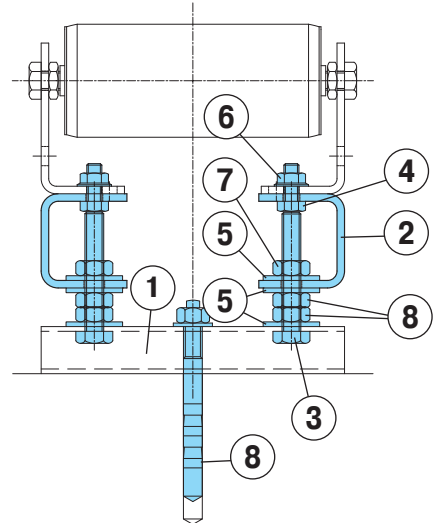
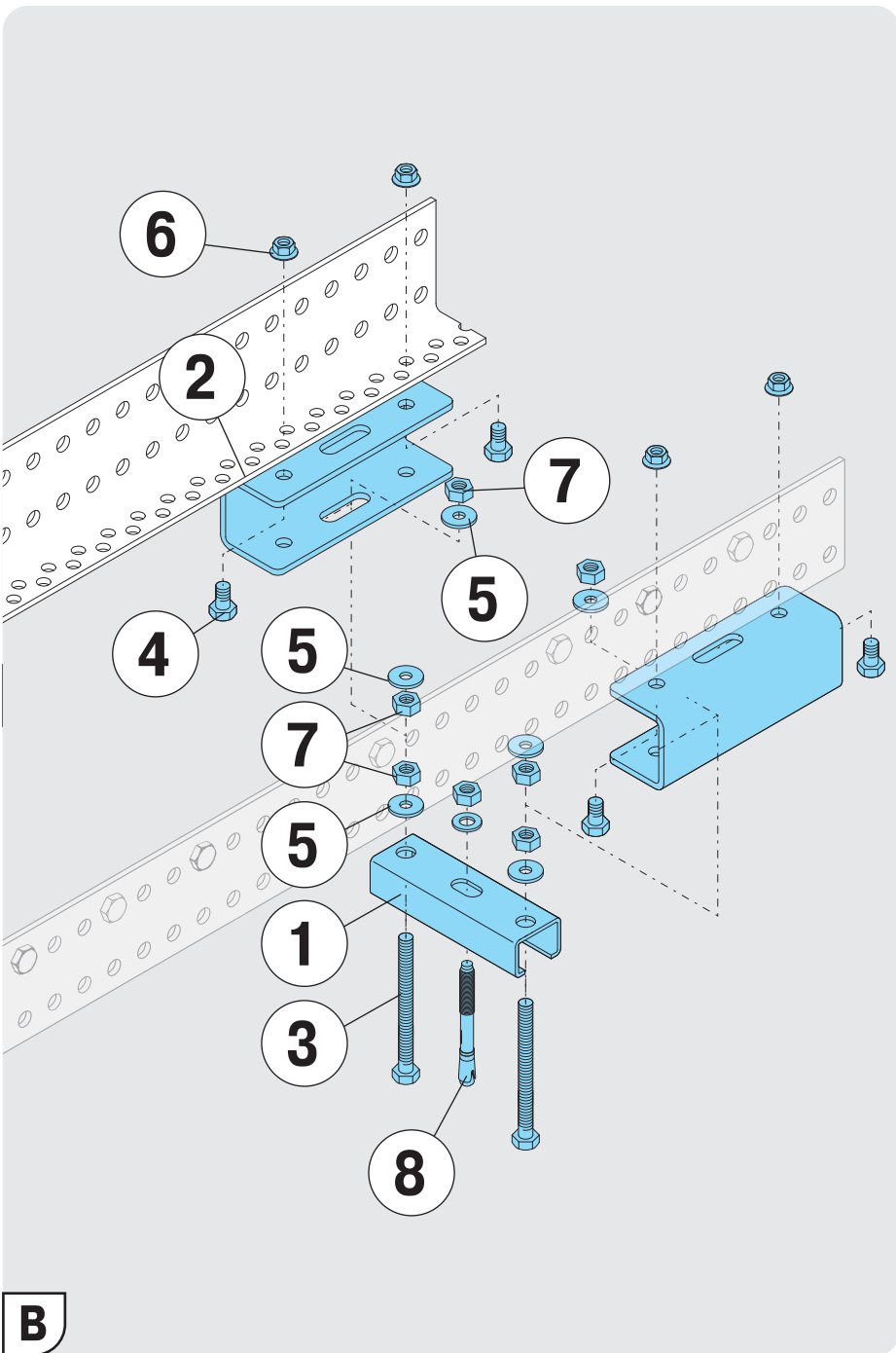
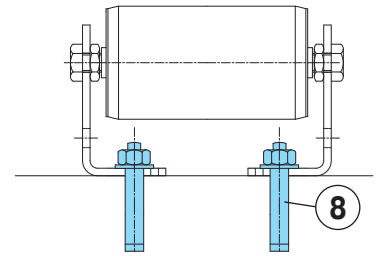
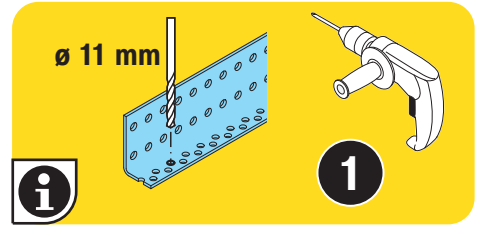
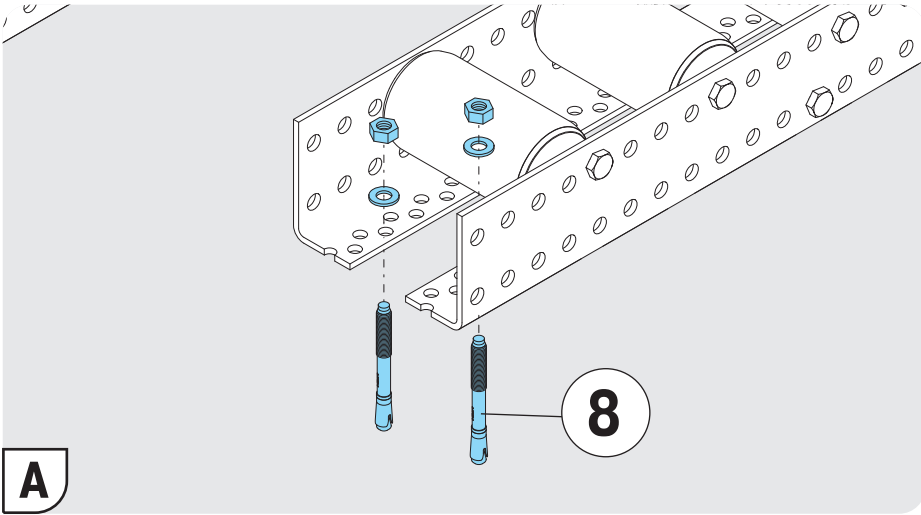

FIFO

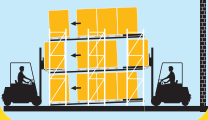

LIFO



PROFLOW

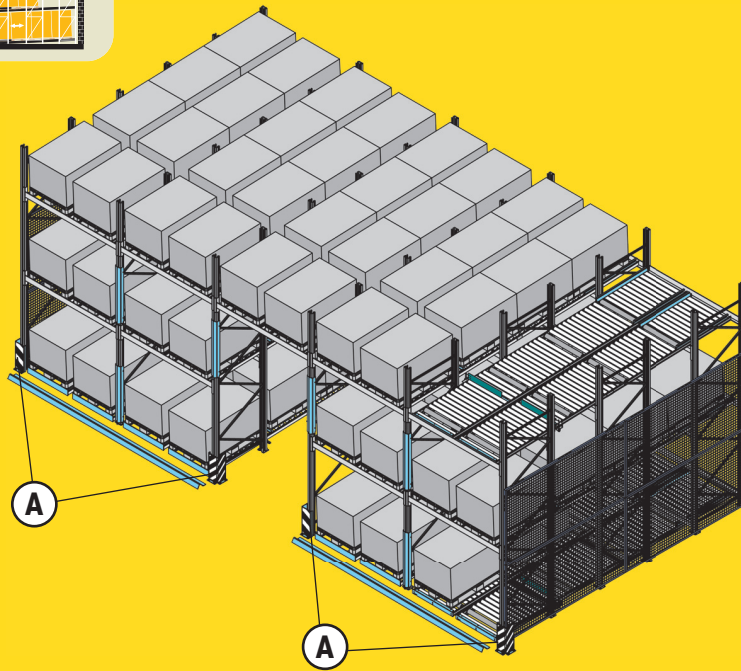

A

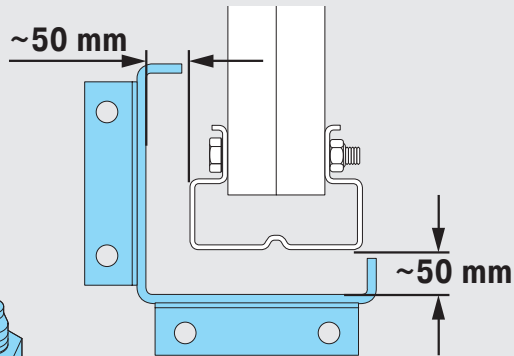

I12

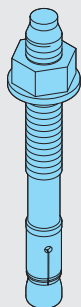
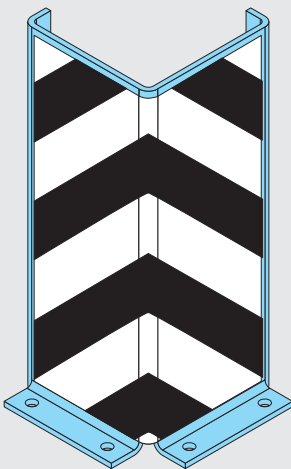
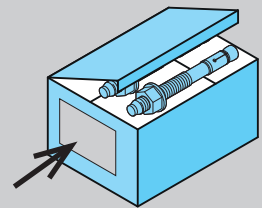

4x
HST3 / M12x115 40/20

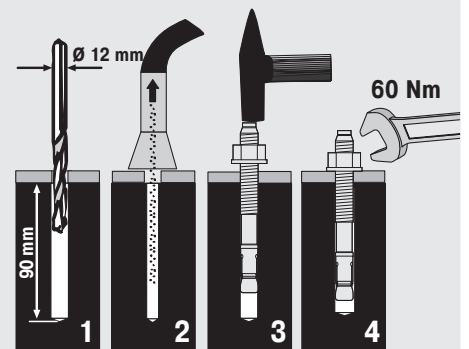

FIFO

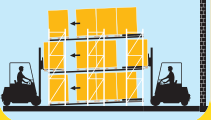

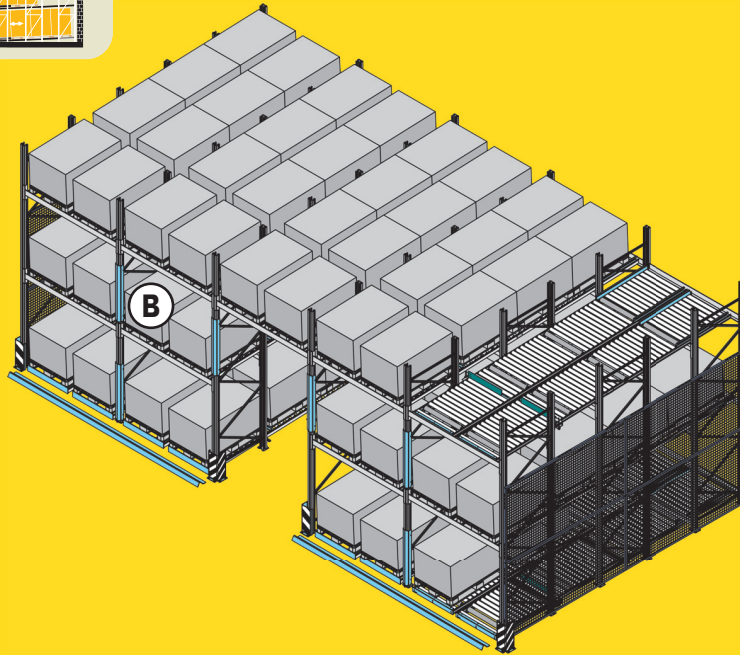
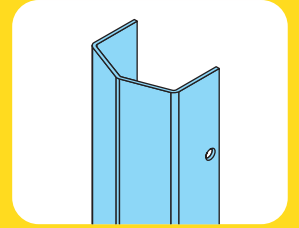

LIFO

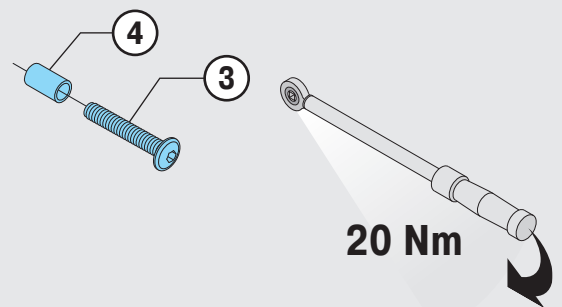
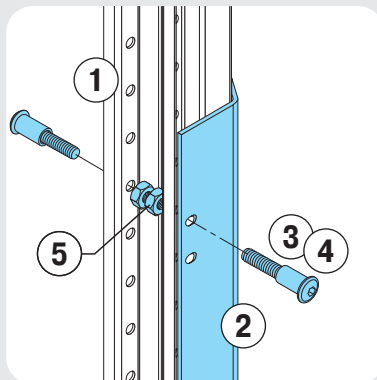
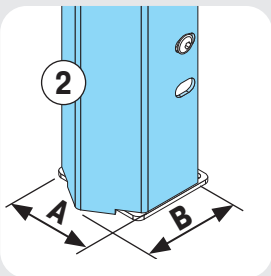

PROFLOW

B

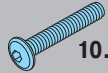

	1	2	3	5	4
			 10.9 DIN EN ISO 7380	 10 DIN EN ISO 4032	
		(A x B) 1x	4x		
P2		91,5 x 105 mm	M10 x 35	M10	14 x 1,5 x 21 mm
P3		101,5 x 101,5 mm	M10 x 40	M10	14 x 1,5 x 25 mm
P4-P6		121,5 x 106 mm	M10 x 40	M10	14 x 1,5 x 25 mm
P7		126 x 128,5 mm	M10 x 50	M10	14 x 1,5 x 34 mm
P12		126 x 128,5 mm	M10 x 50	M10	14 x 1,5 x 34 mm



FIFO

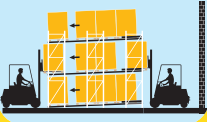

LIFO

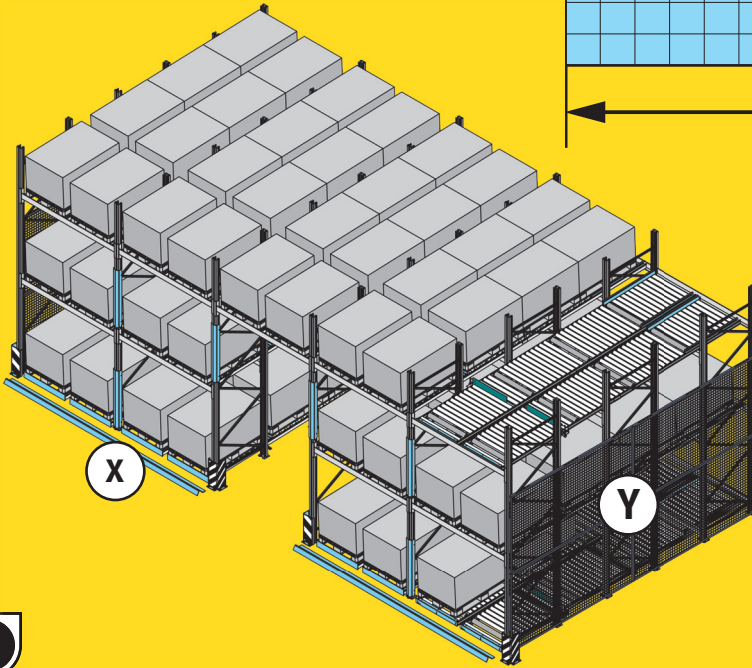
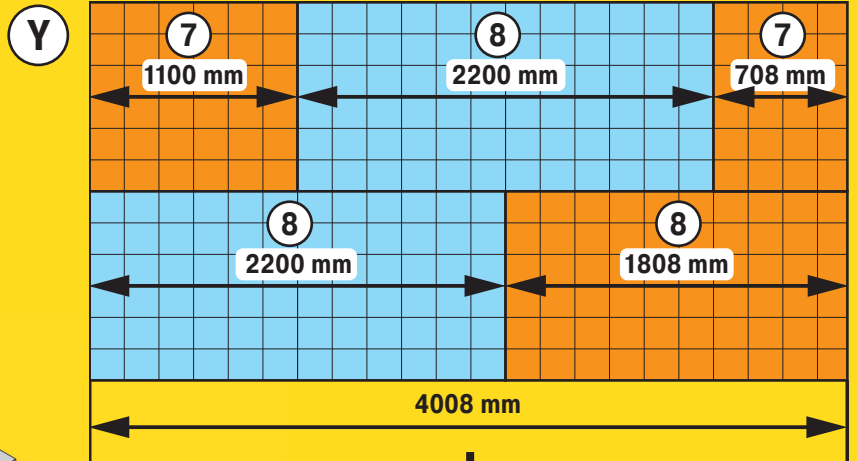

PROFLOW

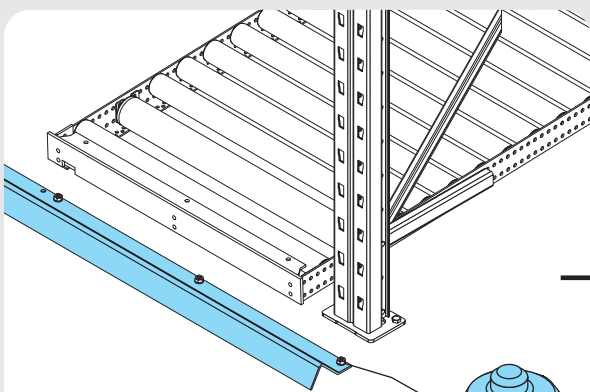

X



!12

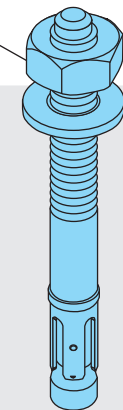
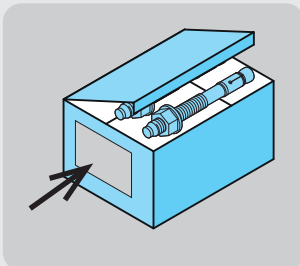

M10/20

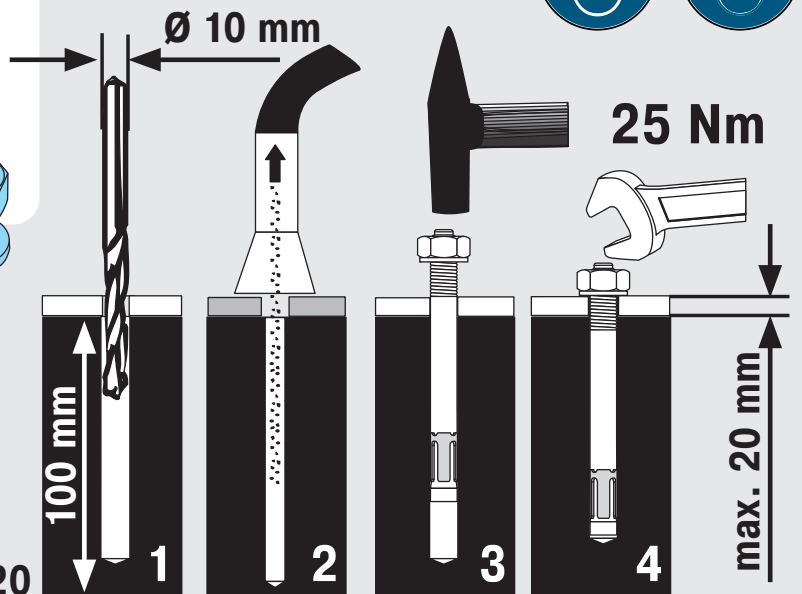

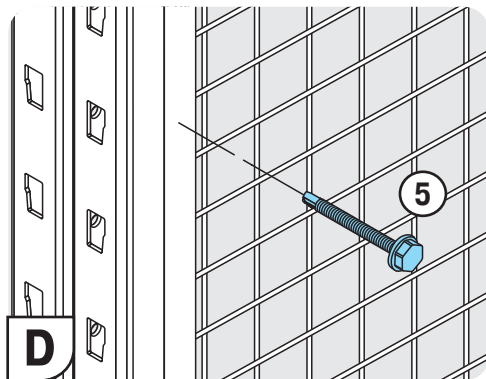
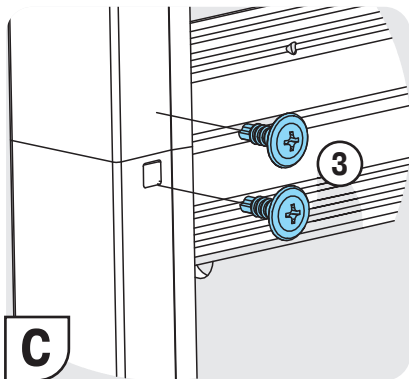
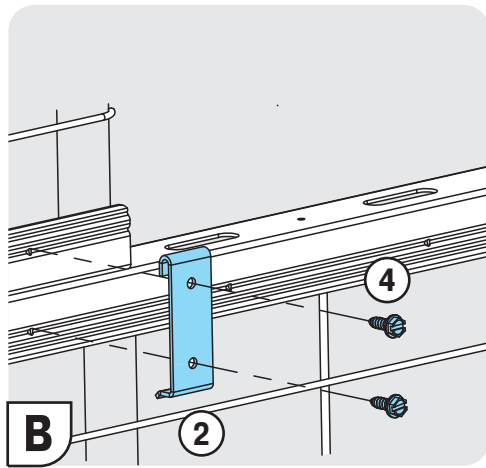
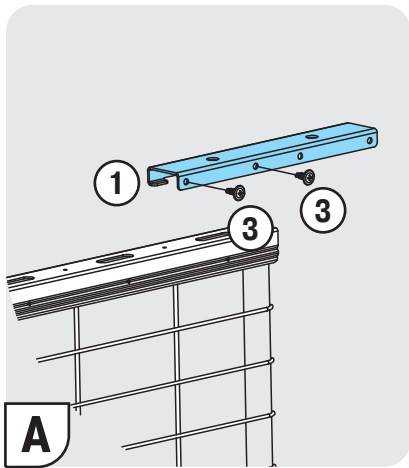
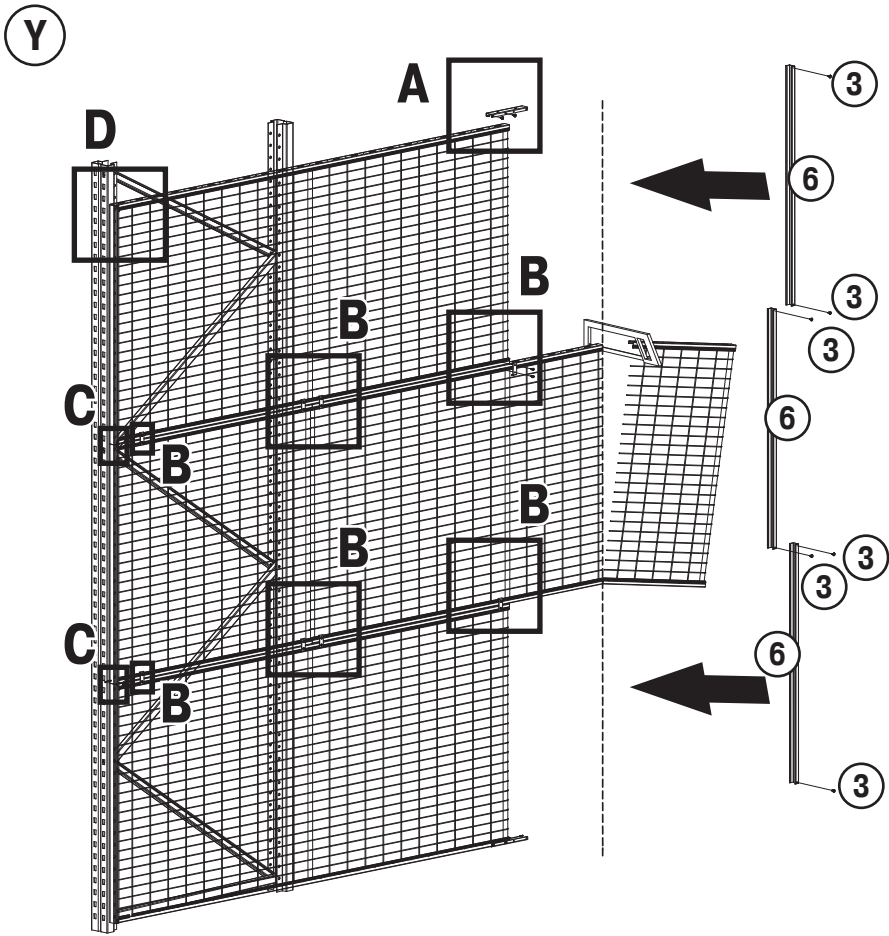

1			1x
2			6x
3			12x
4			12x
5			10x
6		30 x 1000 mm	
7		1100 x 1000 mm	
8		2200 x 1000 mm	



PROFLOW

FIFO

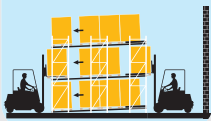

LIFO

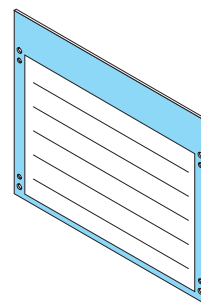

PROFLOW

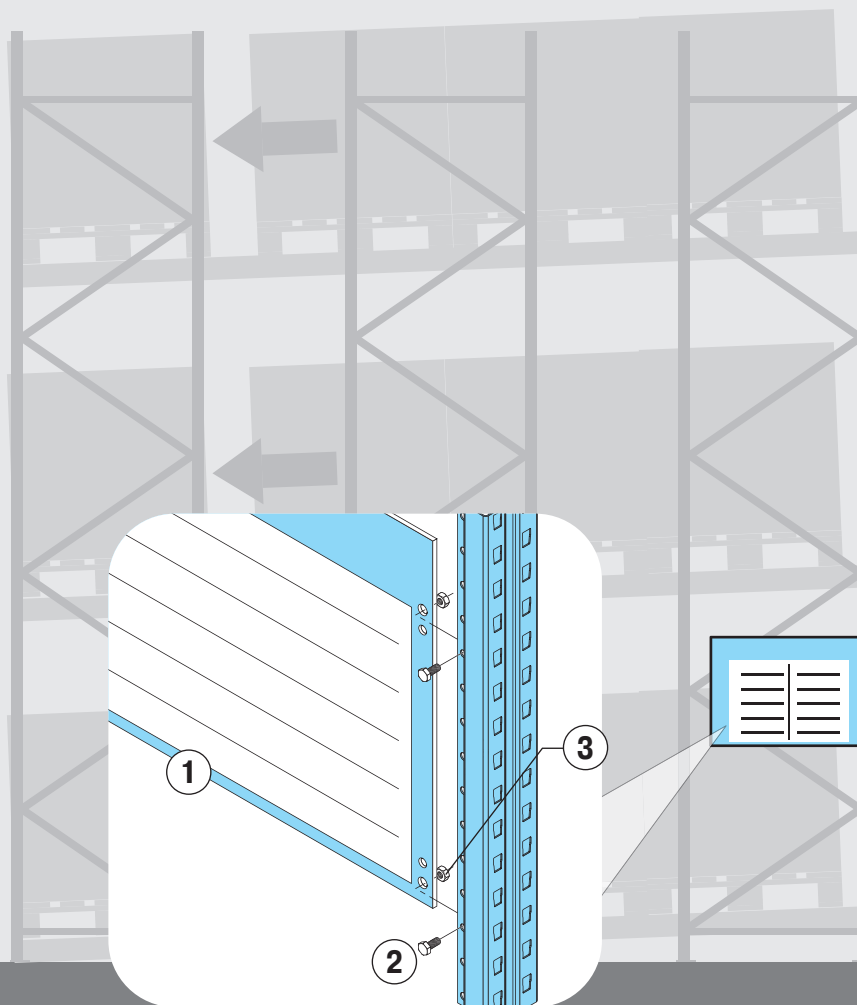

1		335 x 440 mm (235 x 315 mm)		1x
2		M10 x 20 mm DIN EN ISO 4017	8.8	2x
3		M10 DIN EN ISO 4032	8	2x



Fußplatten Typ
Footplate Type **LS1**

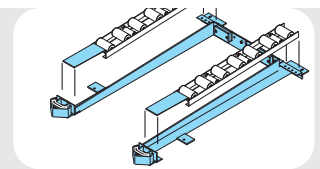
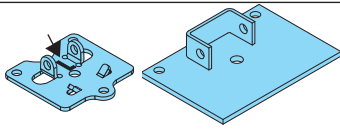

Stützrahmen Typ
Frame Version

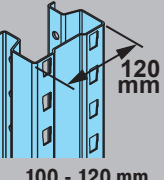
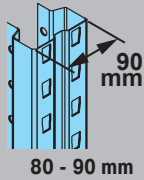
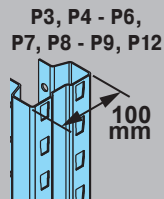
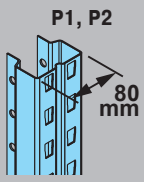

80 - 90 mm

100 - 120 mm

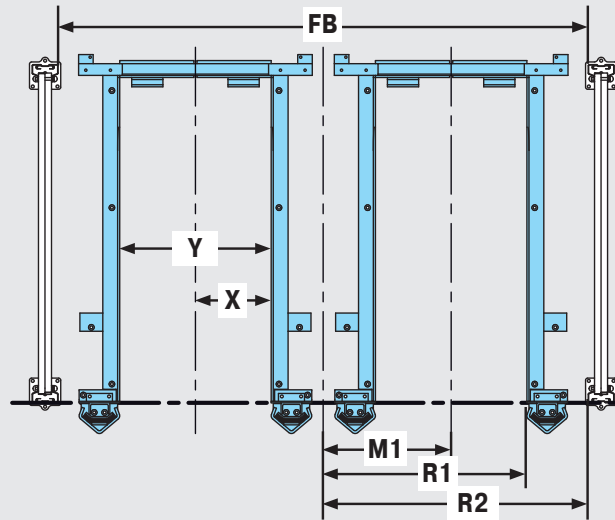

HWE 872 light/robust

FB	1000 mm	2000 mm	3000 mm
M1	500 mm	500 mm	1000 mm
R1	391 mm	791 mm	1291 mm
R2	500 mm	1000 mm	1500 mm
X	291 mm	291 mm	291 mm
Y	582 mm	582 mm	582 mm

HWE 1072 light/robust

FB	1200 mm	2400 mm	3600 mm
M1	600 mm	600 mm	1200 mm
R1	391 mm	991 mm	1591 mm
R2	600 mm	1200 mm	1800 mm
X	391 mm	391 mm	391 mm
Y	782 mm	782 mm	782 mm

HWE 872 robust

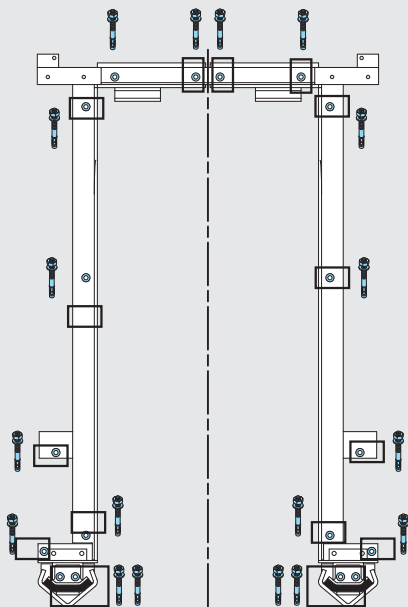

M10 x 20
18x

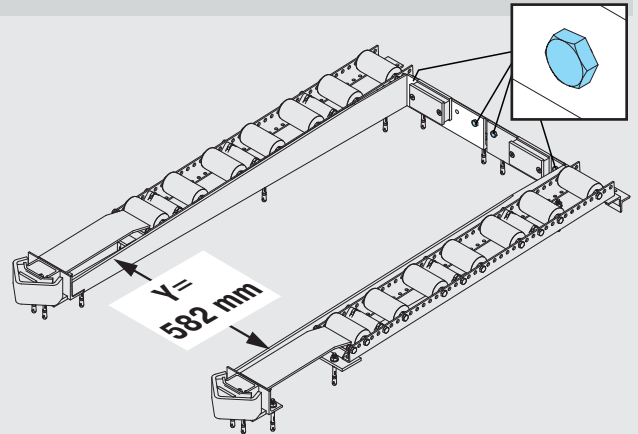

HWE 1072 robust

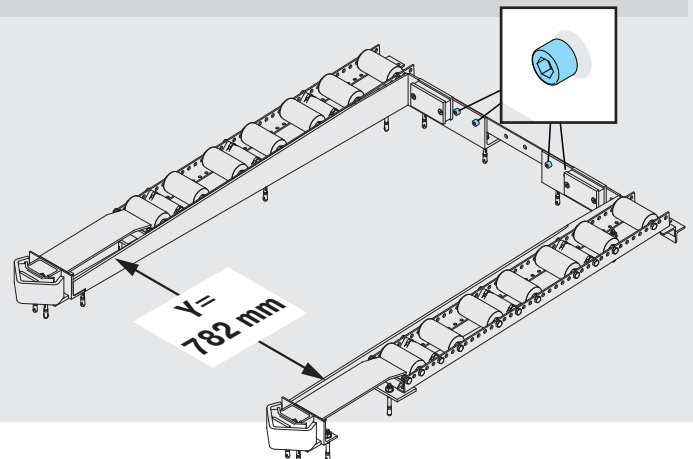

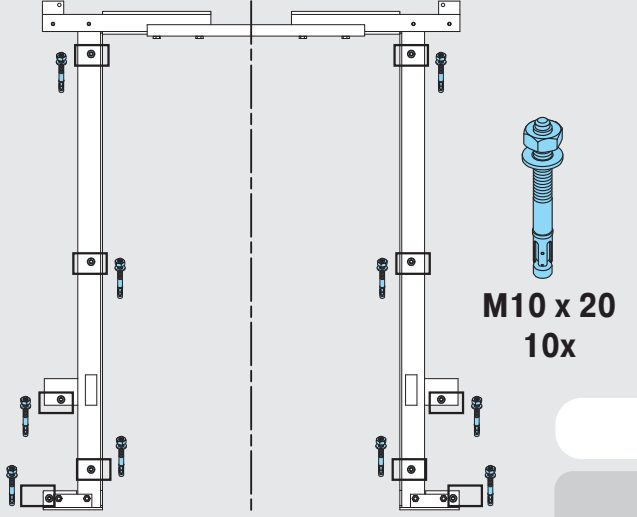
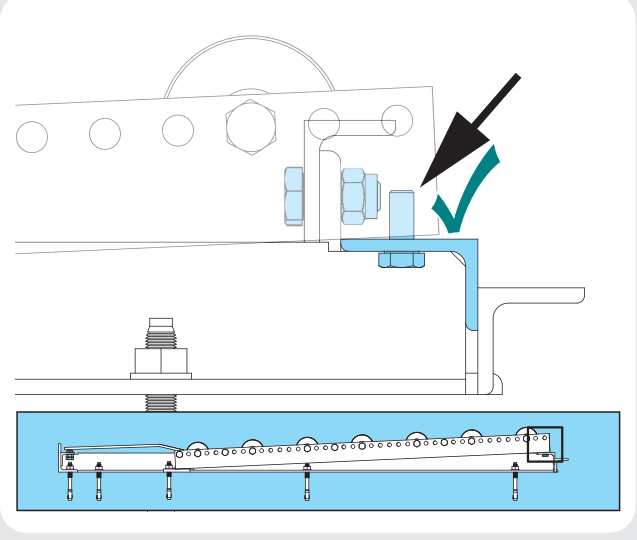
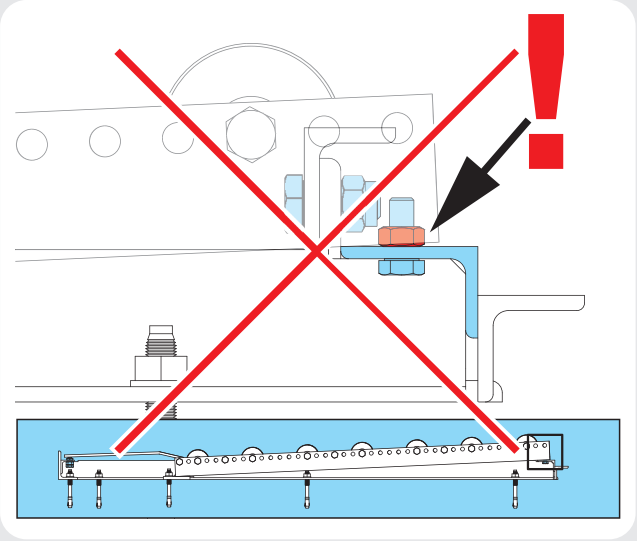

M10 x 20
10x

!12

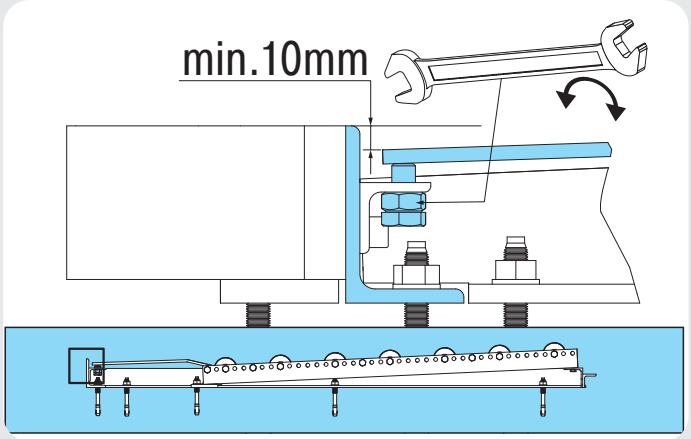
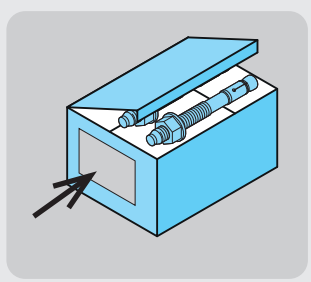

HWE 872 light

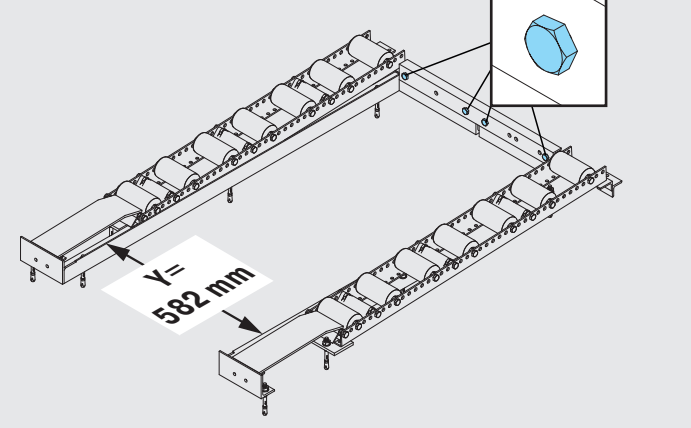

HWE1072 light

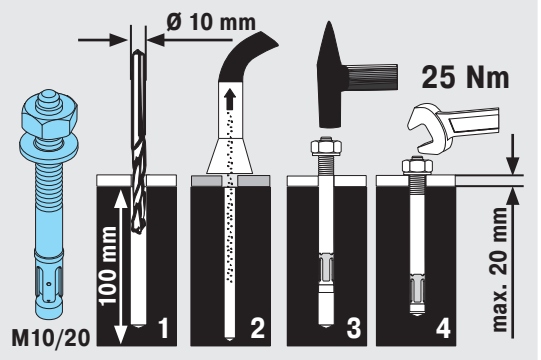
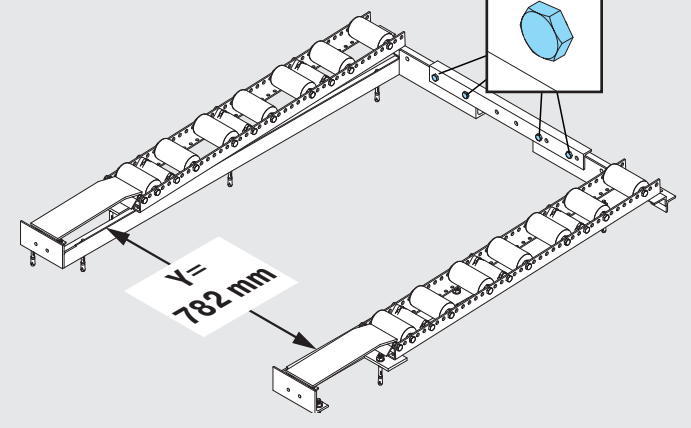

Stützrahmen Typ
Frame Version

Fußplatten Typ
Footplate Type
LS2

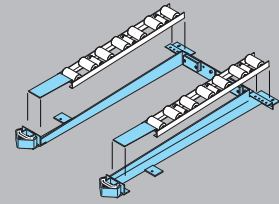
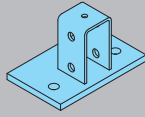

P1, P2

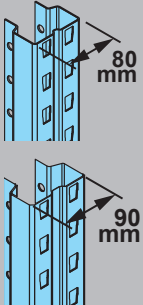

80 - 90 mm

min. 1100 mm



min. 2000 mm

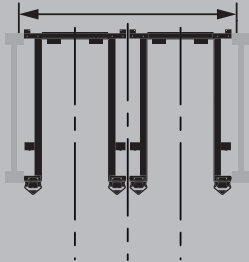

min. 3000 mm

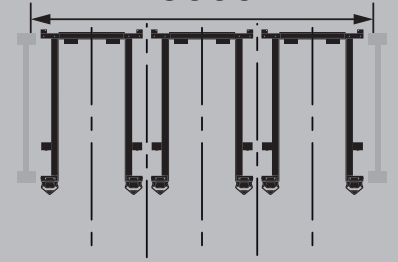

**P3, P4 - P6,
P7, P8 - P9**

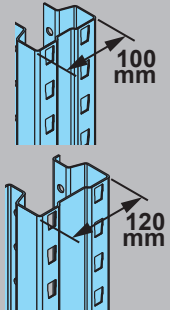

100 - 120 mm

min. 1000 mm

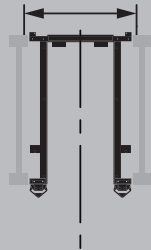

min. 2000 mm

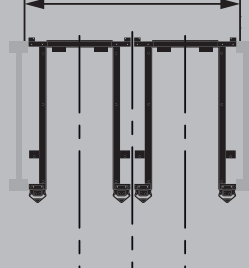

min. 3000 mm

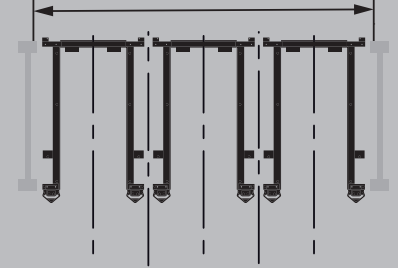

P12

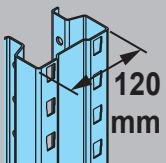

120 mm





<p>Stützrahmen Typ Frame Version</p>	<p>Fußplatten Typ Footplate Type LS3, LS4</p>	
<p>P1, P2</p> <p>80 mm 90 mm</p> <p>80 - 90 mm</p>		
<p>P3, P4 - P6, P7, P8 - P9</p> <p>100 mm 120 mm</p> <p>100 - 120 mm</p>	<div style="display: flex; justify-content: space-around; align-items: flex-start;"> <div style="text-align: center;"> <p>min. 1000 mm</p> </div> <div style="text-align: center;"> <p>min. 2000 mm</p> </div> <div style="text-align: center;"> <p>min. 3000 mm</p> </div> </div>	
<p>P12</p> <p>120 mm</p> <p>120 mm</p>		



PROFLOW

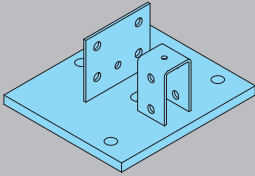
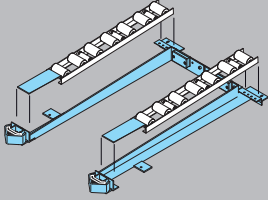
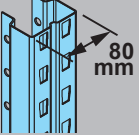
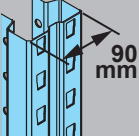

PROFLOW

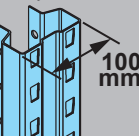
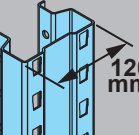
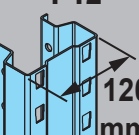
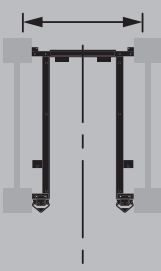
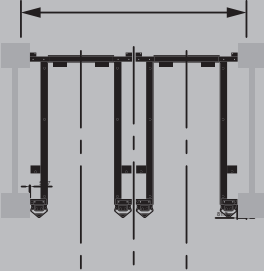
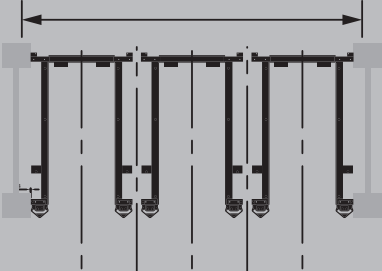
<p>Stützrahmen Typ Frame Version</p>	<p>Fußplatten Typ Footplate Type LS5</p> 	
<p>P1, P2</p>  <p>80 mm</p>  <p>90 mm</p> <p>80 - 90 mm</p>		
<p>P3, P4 - P6, P7, P8 - P9</p>  <p>100 mm</p>  <p>120 mm</p> <p>100 - 120 mm</p>		
<p>P12</p>  <p>120 mm</p> <p>120 mm</p>	<p>min. 1100 mm</p>  <p>min. 2000 mm</p>  <p>min. 3100 mm</p> 	

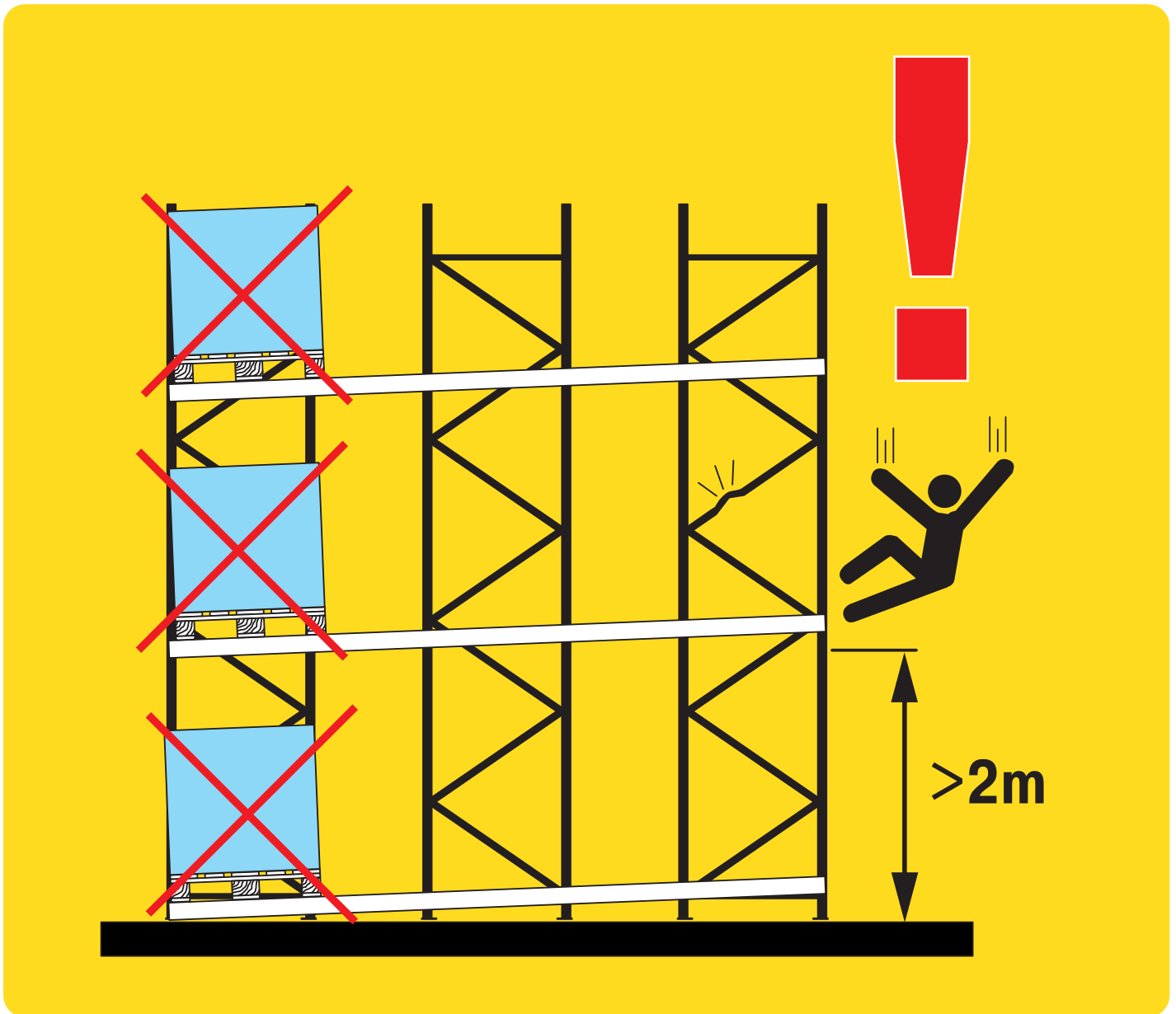
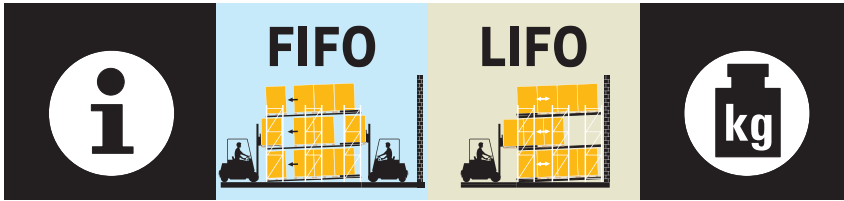



PROFLOW

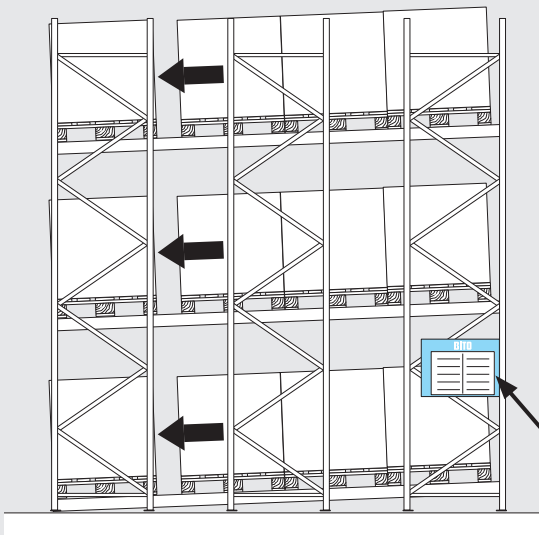
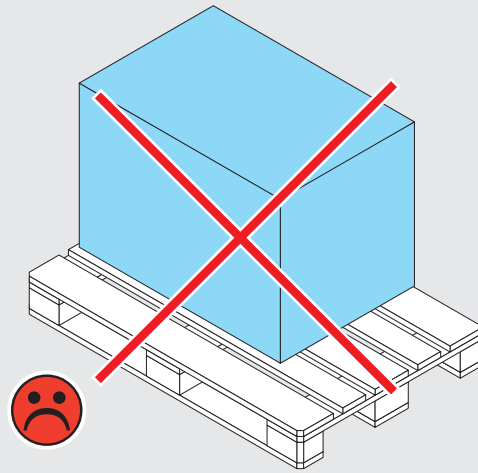
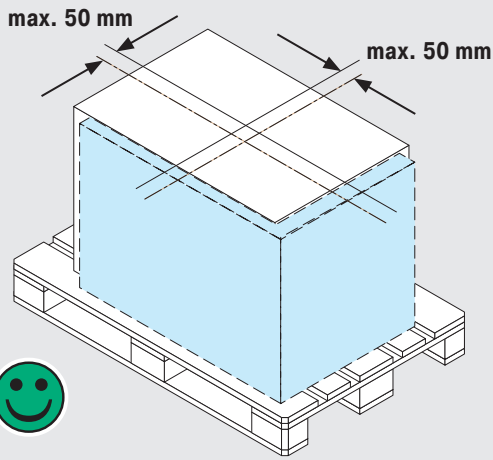

max. 0,3 m/s

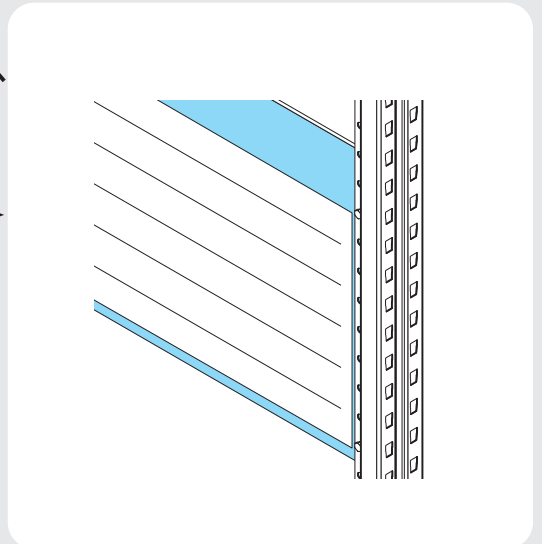
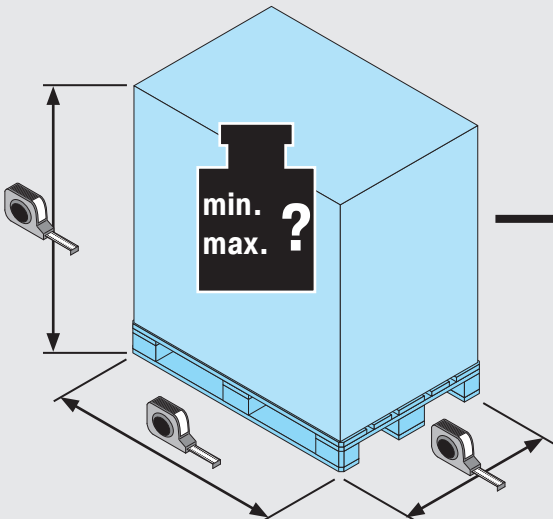
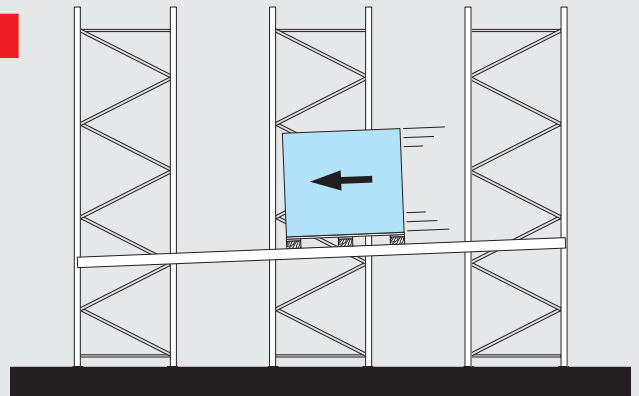

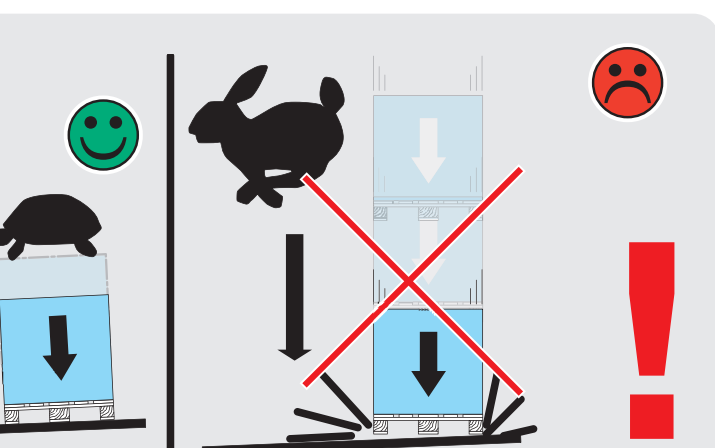
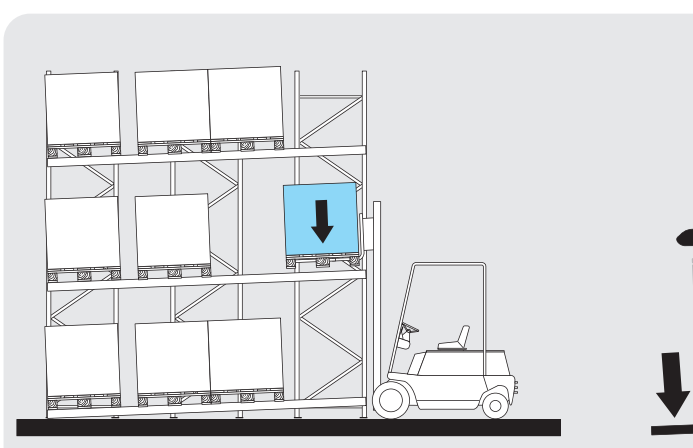
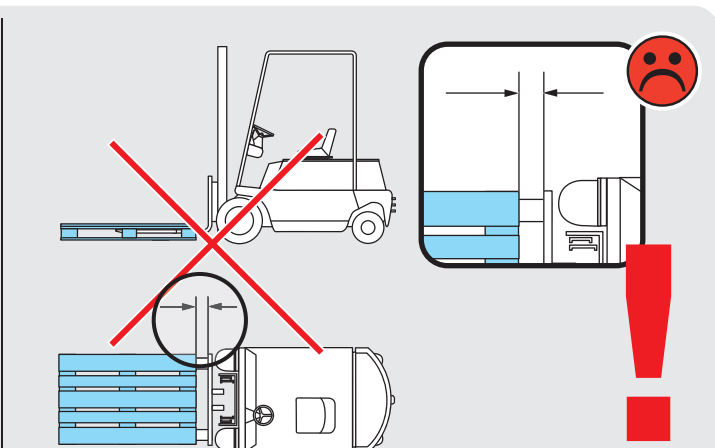
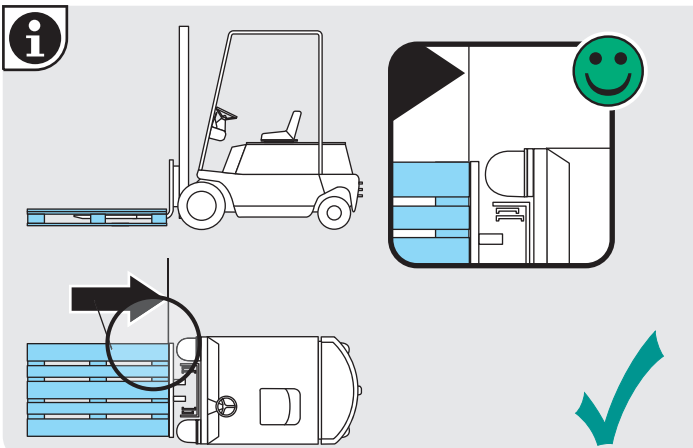
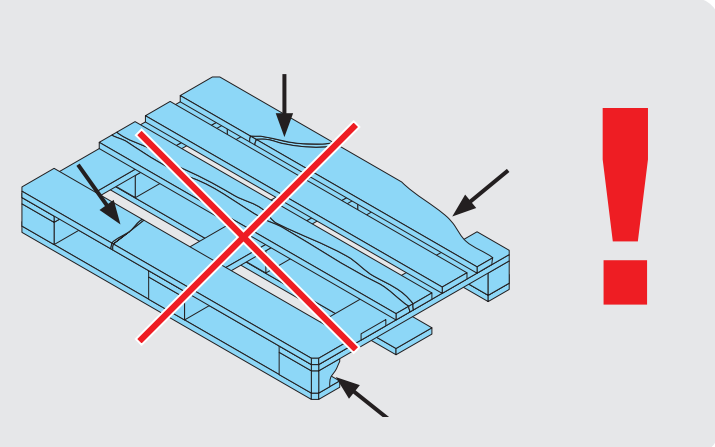
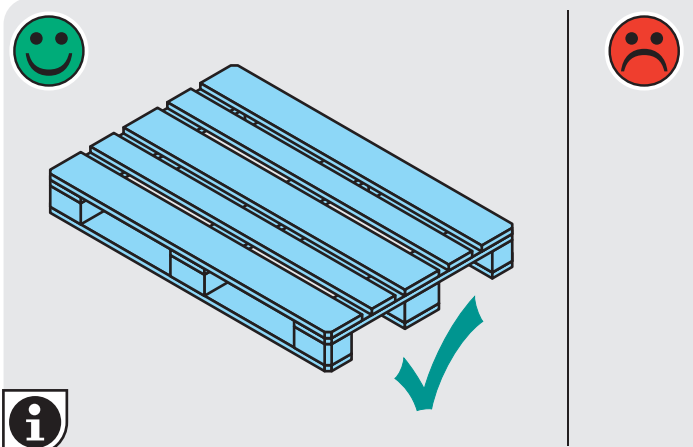
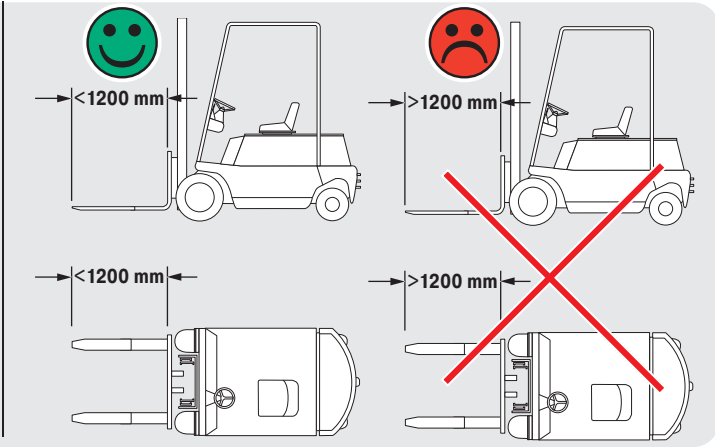
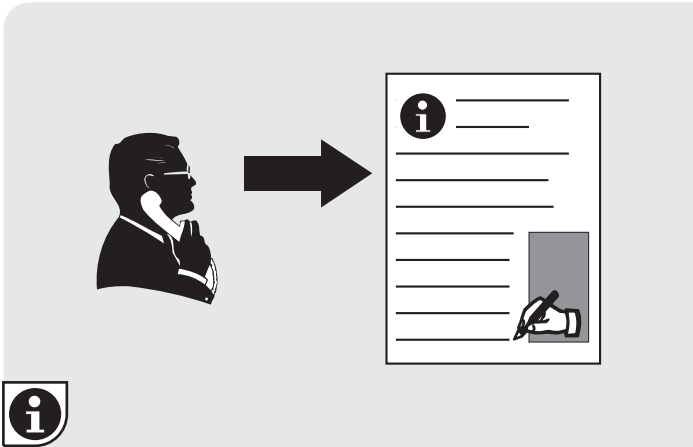

PDS Access-Kit



PROFLOW

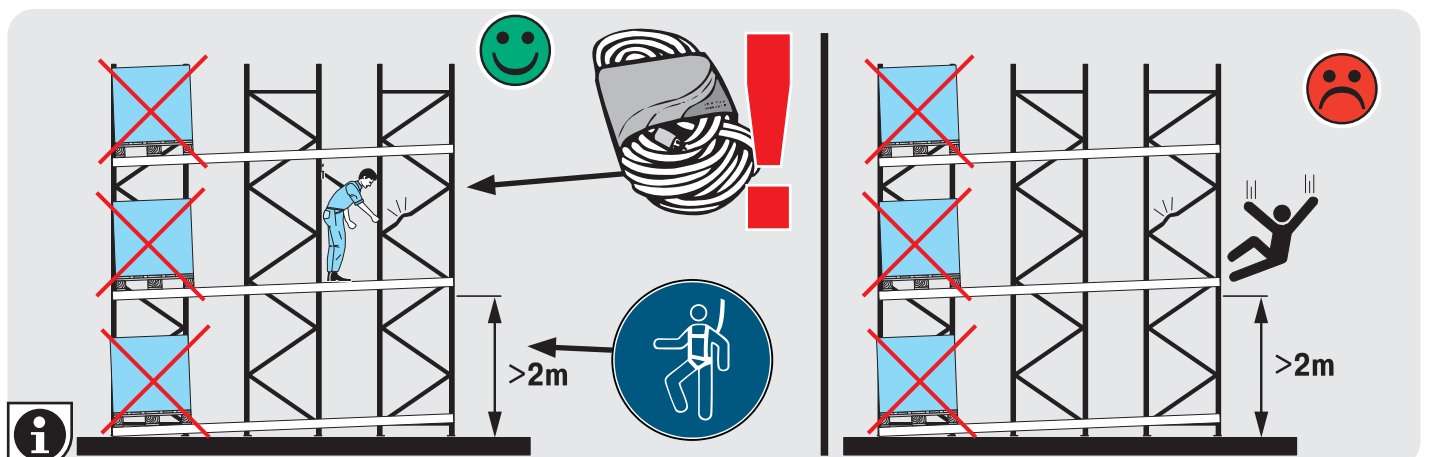
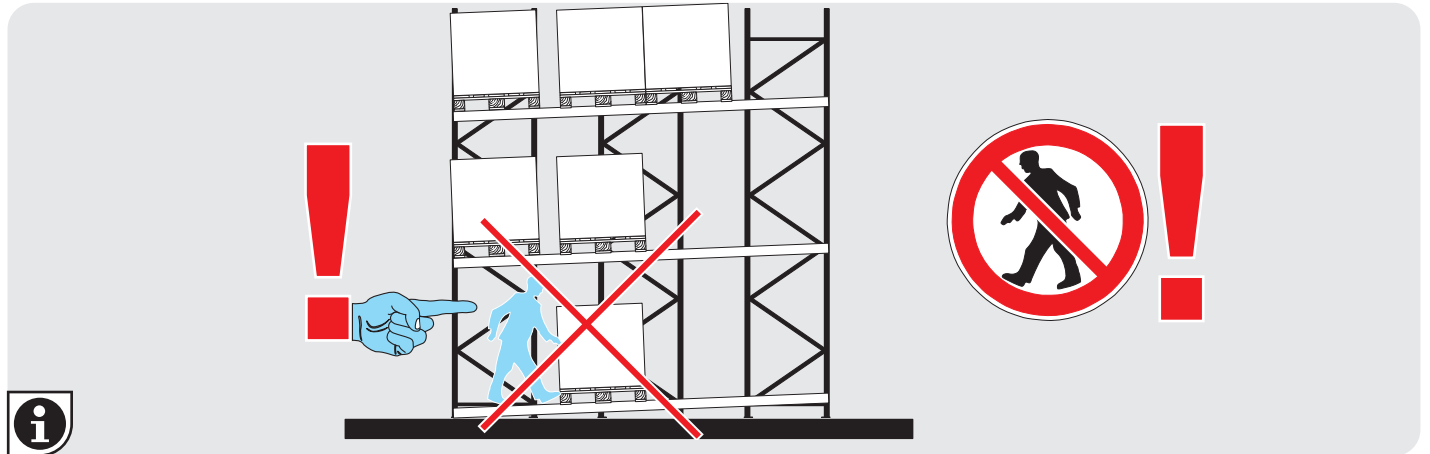

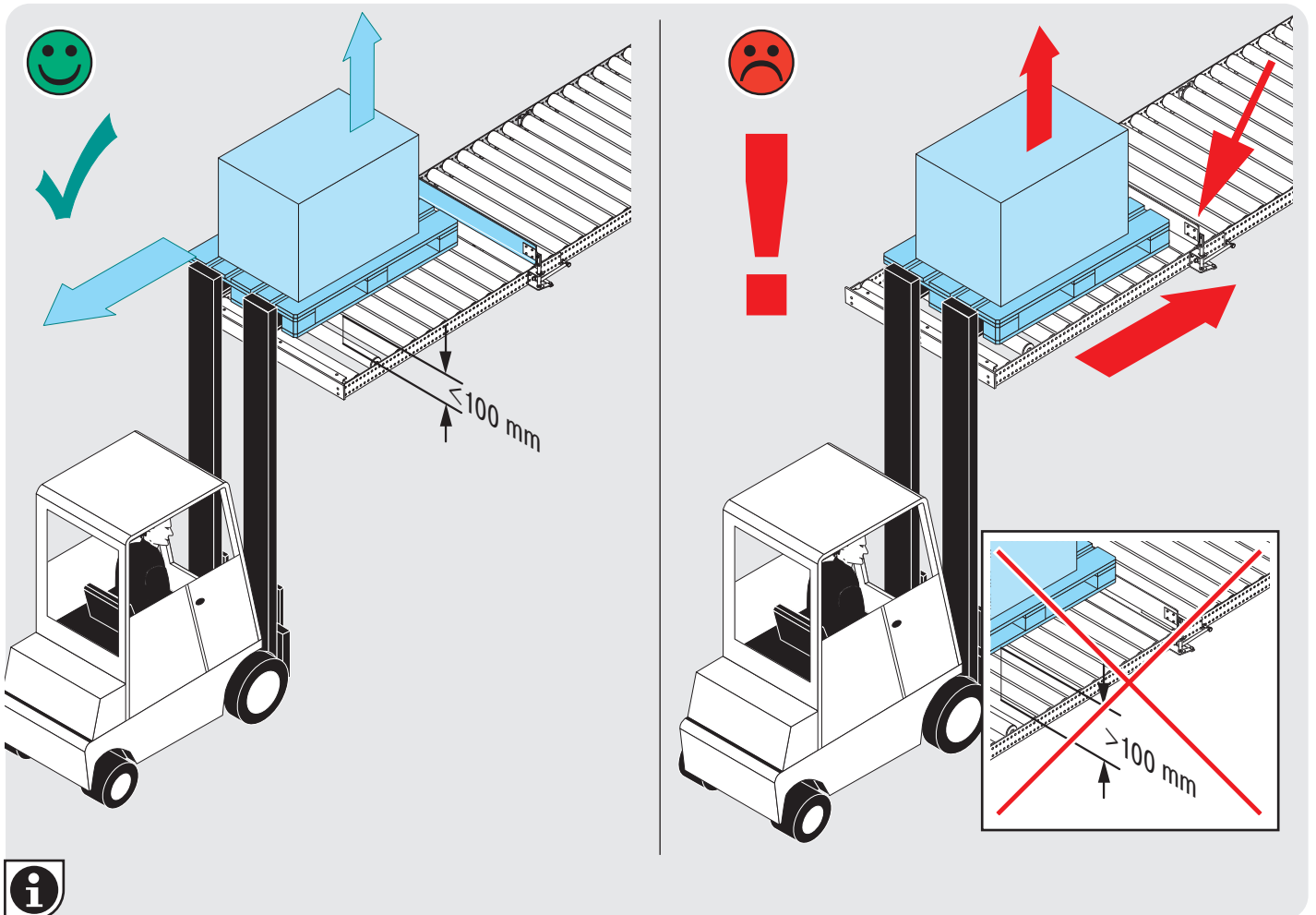
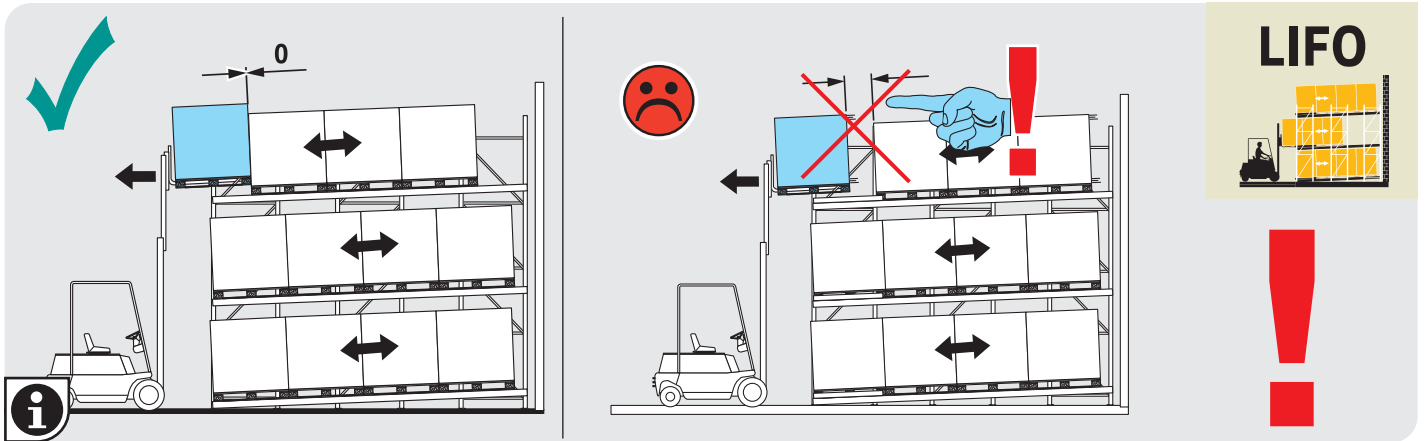
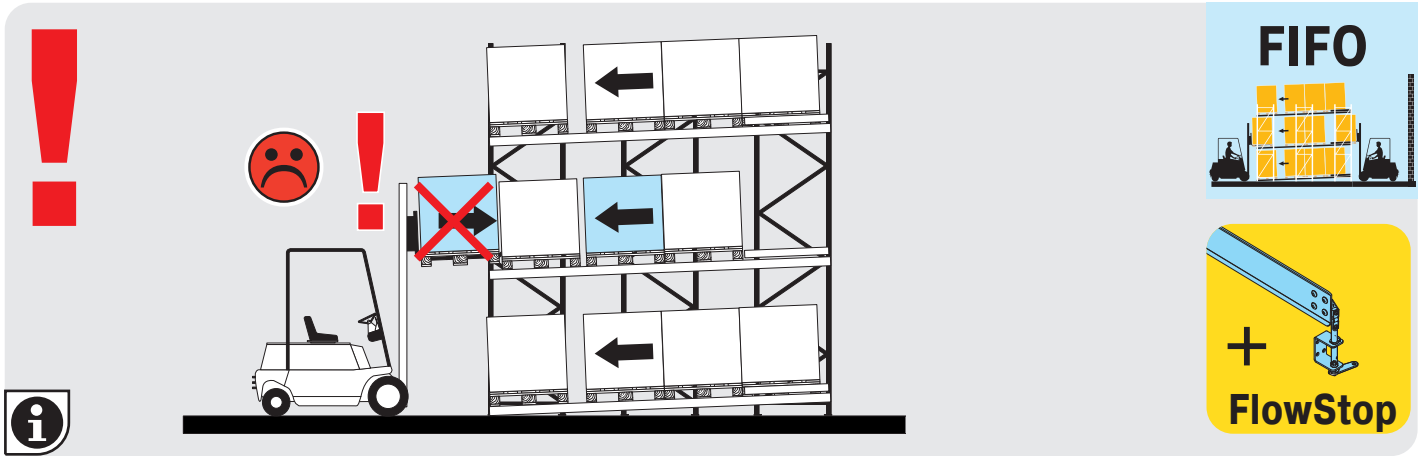



WE TAKE THE TIME
TO GIVE ADVICE.

+49 (6753) 122-922

**BITO-LAGERTECHNIK
BITTMANN GMBH**

Obertor 29
D-55590 Meisenheim

Tel. +49 6753 122 - 0
Fax +49 6753 122 - 399

info@bito.com

www.bito.com



You can also join us online.



www.bito.com

A **BIT** OF YOUR LIFE.

BITO
LAGERTECHNIK